

University of New Hampshire

University of New Hampshire Scholars' Repository

Center for Coastal and Ocean Mapping

Center for Coastal and Ocean Mapping

7-2004

ENC Distribution Options Based on WEND

Lee Alexander

University of New Hampshire, Durham, lee.alexander@unh.edu

Follow this and additional works at: <https://scholars.unh.edu/ccom>



Part of the [Oceanography and Atmospheric Sciences and Meteorology Commons](#)

Recommended Citation

Alexander, Lee, "ENC Distribution Options Based on WEND" (2004). *Center for Coastal and Ocean Mapping*. 1168.

<https://scholars.unh.edu/ccom/1168>

This Report is brought to you for free and open access by the Center for Coastal and Ocean Mapping at University of New Hampshire Scholars' Repository. It has been accepted for inclusion in Center for Coastal and Ocean Mapping by an authorized administrator of University of New Hampshire Scholars' Repository. For more information, please contact Scholarly.Communication@unh.edu.

ENC Distribution Options Based on WEND

White Paper – Draft v3

22 July 2004

Introduction

The electronic chart is a new technology capable of continuously determining a vessel's position in relation to land, charted objects, aids-to-navigation, and unseen hazards. As a real-time navigation system, electronic charting provides significant benefits in terms of improvements in navigation safety, efficiency of maritime transportation, and marine environmental protection.

In terms of system components, features and functional capability, there are two basic types of electronic charts. The most advanced form is an Electronic Chart Display and Information System (ECDIS). All other types can be regarded, generically, as Electronic Chart Systems (ECS). For an electronic chart to be considered an ECDIS, it must comply with the Performance Standards for ECDIS formally adopted by the International Maritime Organization (IMO) in November 1995 [1]. In particular, an ECDIS must use official Electronic Navigational Chart (ENC) data in order to meet the chart carriage requirements contained in regulation V/19 of the 1974 SOLAS Convention as amended in 2000 [2]. IMO specifically requested that Member Governments have their National Hydrographic Offices (HOs) produce electronic navigational charts (ENCs) and the associated updating service as soon as possible, and to ensure that manufacturers conform to the performance standards when designing and producing electronic charting equipment.

The WEND Concept

In an effort to facilitate the distribution and use of official ENC data, the Worldwide Electronic Navigational Chart Data Base (WEND) was established by IHO in 1992 during the 14th International Hydrographic Conference. It was in response to proposal by the Norwegian Hydrographic Service to establish a worldwide Electronic Chart Center (ECC). Rather than a single, ENC distribution center, the WEND concept is based on a number of Regional ENC Coordinating Centers (RENCs) being established throughout the world [3]. Based on this approach, IHO Member States would cooperate to produce an integrated database containing ENCs from a number of Hydrographic Offices (HOs) within a particular region.

As outlined in Annexes 4-6 of the “Report of the Special Committee on WEND” [1], WEND is defined as:

1. *A common worldwide network of ENC datasets, based on IHO standards, designed to specifically meet the needs of international maritime traffic using ECDIS, which conforms to IMO Performance Standards.*
2. *The System will utilize HO national ENC datasets, which are integrated and may be distributed and updated through regional centres.*
3. *WEND represents an IHO system based on the co-operation of participating Member States.*

Following its adoption by IHO Member States, the Special Committee on WEND became a regular IHO committee tasked with implementing the WEND concept. The IHO WEND Committee has met annually since 1994.

The WEND Concept includes two primary components:

1. A set of principles for cooperation (the so-called WEND Principles)
2. A conceptual model (see Figure 1) for its data flow and organizational relationships

Figure 1 – The conceptual WEND model (after Hecht 2002).

WEND Principles

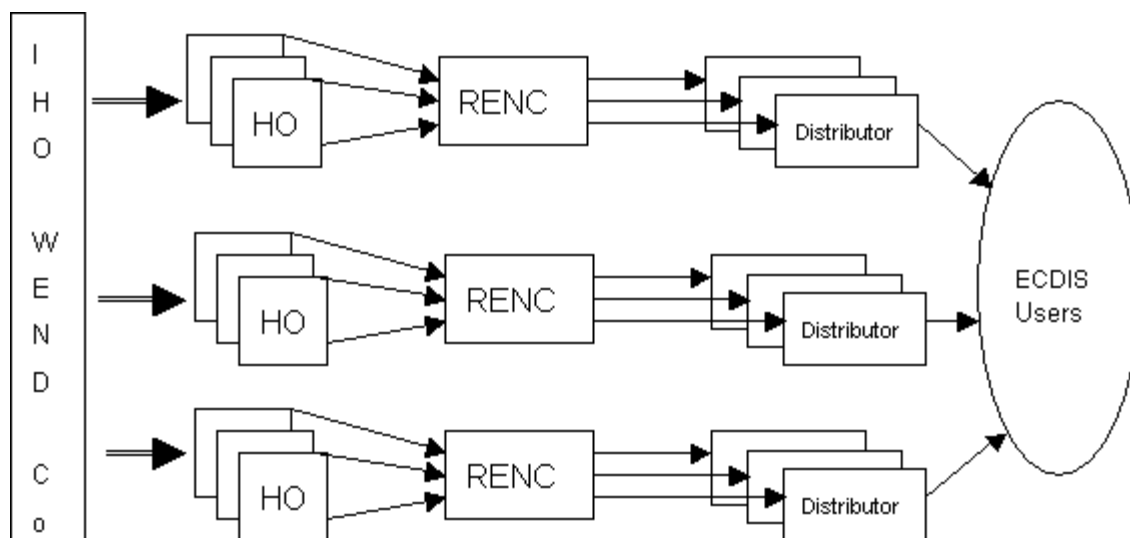

As discussed in a recent article, the WEND Principles fall into two primary groups [4].

1. Principles regulating internal, mutual relationships between HOs related to:
 - ownership and

responsibility

- cooperation and coordination
- reimbursement and financial arrangements
- assistance and training

2. Principles defining the core business to be conducted under the umbrella of WEND, this includes:

- standards and quality management
- distribution
- updating

Ideally, the WEND Principles should:

- encourage ENC production in areas without adequate coverage,
- avoid duplication of ENC production (i.e., overlapping areas), and
- facilitate ENC implementation through cooperation between producing nations for data production, sharing, and distribution.

The WEND principles do not cover the distribution of paper charts or Raster Navigational Charts (RNC). However, for most parts of the world, particularly those outside the high-traffic ports and waterways (e.g., major European ports, Singapore, and Hong Kong) it will not be possible to use ECDIS for navigation without relying on some RNC data, commercial electronic chart data, or paper charts for a significant portion of a ship's voyage.

RENC

The WEND Concept does not provide a specific definition of a Regional ENC Center (RENC). Instead, it refers to a 'regional center' as a means for data distribution. On the other hand, as shown in the conceptual WEND Schema (Figure 1), a RENC can be whatever two or more cooperating HOs decide establish in order to facilitate ENC distribution and services [2]. Originally, this was expected to be a physical center or facility in proximity to HOs in a particular region. However, as pointed out by a former IHO Director, "modern data communication has no boundaries and in the servicing of a database, and the need to consider adjacency may be less important the need to service customers [4]."

RENC Models

Two RENC models have emerged so far:

1. ENC Coordinating Center (ECC)
2. Virtual RENC (VRENC).

However, some countries have made a purposeful decision not to form or join in any type of RENC, and are acting independently (i.e., go-it-alone).

1. ENC Coordinating Center



Under this model, a dedicated staff is employed full-time to operate at an established facility (e.g., a **bureau**) on behalf of cooperating HO's. Each cooperating HO provides its ENC data to the ECC, who ensures that the products are consistent with the data received from other contributing countries. The ECC also acts as a single wholesaler of the collective set of ENC data that it holds. The only ECC to be established in this way was *PRIMAR*TM (formerly known as the European ENC Coordinating Centre). *PRIMAR*TM was established in 1996, and funded principally by the Norwegian Hydrographic Service and the UK HO. For the 12 participating HOs (Belgium, Denmark, Finland, France, Germany, The Netherlands, Norway, Poland, Portugal, Spain, Sweden and the United Kingdom), services provided included ENC production, data format validation, data integrity and access control (encryption), marketing, wholesale distribution, and collection and distribution of royalties. *PRIMAR*TM also offered an official ENC service to mariners via its own appointed distributor network [6].

In 2001, it became clear that for *PRIMAR*TM, the operating costs were higher and revenue expectations were lower than expected. As such, in late 2001 *PRIMAR*TM split into two separate RENCs: Norwegian Hydrographic Service RENC and the UK International Centre for ENCs.

NHS RENC

On 1 April 2002, the Norwegian Hydrographic Service (NHS) re-established a RENC in Stravanger, Norway that included five cooperating HOs from the former *PRIMAR*TM: Denmark, Finland, France, Norway and Sweden. As described in the Executive Summary of the Operational Proposal [7], the NHS RENC is a simplified version of RENC service previously provided by *PRIMAR*TM. To be operated as fit-for purpose and a non-profit organization, it will maintain all key elements of the former *PRIMAR*TM functionality, but at considerably lower cost. Bilateral agreements between cooperating HOs and NHS are the basis for the operation and provision of the relevant RENC cooperation, responsibilities, and services. Continued development of the NHS RENC operation and strategy will be through consultation with the participating HOs.

The NHS RENC intends to increase and maximise utilisation of ENCs by engaging in non-exclusive strategic alliances with authorised distributors, and by establishing comprehensive distribution mechanisms based on market knowledge. NHS RENC will focus on active distributors in order to provide an efficient and effective service, aiming at global coverage. Continued operation of the *PRIMAR*TM security service will be used to support existing ENC distribution. Cooperating HOs and NHS RENC will collectively ensure a harmonised and validated ENC product database complying with all relevant ENC quality standards. The NHS RENC service is based on a cost recovery model from 2002. All sales revenues will be returned to each national HO, or alternatively, the NHS RENC could retain the sales income to offset HO financial requirements.

The NHS RENC will cooperate with other RENCs in accordance with WEND principles, and supports the Virtual RENC (VRENC) concept that enables other HOs worldwide to join the NHS RENC with full control and access to their national product database.

Additional information may be obtained by contacting:

Kjell Biekevold, Marketing Director (kjell.birkevold@statkart.no)
Norwegian Hydrographic Service (www.statkart.no/sksk)

Rune Holst Johnsen, Marketing Manager (rune.johnsen@primar.org)
*PRIMAR*TM Stavanger (www.primar.org/stvanger)

International Centre for ENCs (IC-ENC)

On 1 July 2002, the United Kingdom Hydrographic Office (UKHO) and five other European HOs (Belgium, Germany, The Netherlands, Portugal, and Spain) established the International Centre for ENCs (IC-ENC) as a successor to *PRIMAR*TM. Similar to the former *PRIMAR*TM, IC-ENC is modelled around the concept of an RENC as envisaged under the IHO WEND concept. As described in the IC-ENC "A Guide to the New RENC" [8], IC-ENC will operate on a not-for-profit basis using established distribution mechanisms. IEC will follow the original *PRIMAR*TM model by continuing to validate each ENC before releasing it into its database. It will also use a deferred payment system to recover its costs, avoiding the need for cooperating HOs to invest new money in IC-ENC. However, unlike the former *PRIMAR*TM, IC-ENC does not operate an end-user service. Instead it will take advantage of the expertise and experience of existing service providers, allowing these companies to develop their own tailored services based on the ENC data. As such it will be the Value-Added Resellers (VARs) that will actually bring the ENCs to the market. In concept, this should reduce the cost and technical complexities of IC-ENC, while at the same time maximizing the availability of the ENCs.

As the operator of IC-ENC, it is the UKHO who establishes the necessary Bilateral Agreement with each cooperating HO. This arrangement sets out the principles of IC-ENC, outlines the provision of

services, and defines relevant operating procedures and financial arrangements. The Bilateral Agreement can either be a standalone document or an extension to an existing arrangement. The IC-ENC seeks to establish the widest coverage of ENC's that is possible. As such, membership in IC-ENC is open to any national HO wishing to join and sign a Bilateral Agreement with the UKHO.

Additional information may be obtained by contacting:

Phil Wainwright (e-mail: phil.wainwright@ic-enc.org)

IC-ENC (www.ic-enc.org)

2. Virtual RENC

Under this model, there are **no new, permanent staff or a centralised organization**. Regional ENC producer nations agree on production standards, areas of coverage, general distribution principles, and related matters to ensure that ENC's across a region are uniform and consistent. It is then left to each ENC producer to ensure that its ENC's meet the agreed requirements of the Virtual RENC (VRENC). Individual HO's are also left to arrange their own marketing and distribution arrangements for their ENC's.

The Mediterranean and Black Sea VRENC is in an advanced stage of implementation, but is as yet operational [9]. Its regional base is the countries of the Mediterranean and Black Sea Regional Hydrographic Commission. Other IHO Regional Hydrographic Commissions have expressed interest in this approach and may adopt a similar model.

Go-It-Alone

Some countries have decided that they do not need to join or establish either a RENC or VRENC. This is the case for both the USA and Canada. Based on the discussions during the recent meetings of the IHO WEND Committee, some of the reasons include:

- there are no other regional ENC producers
- an HO wants to provide an integrated chart service (paper, RNC and ENC)
- an HO has produced so little data that RENC distribution is unwarranted
- an HO cannot come to satisfactory agreements with other HOs or RENCs
- some countries are large enough to become their own RENC

Future of the RENC concept

If the WEND principles are to be followed, then a high level of coordination and cooperation between adjacent ENC producers must occur. As suggested at a recent IHO Workshop on ENC's [10], the choices to achieve this appear to be:

- to establish a bureau similar to:
 - a. Norwegian Hydrographic Service RENC (NHS RENC)
 - b. UK HO International Centre on ENC's (IC-ENC)
- to work through regional cooperation (the virtual RENC model)
- to observe all the IHO requirements but effectively produce and distribute ENC's without involving other HO's (i.e., be your own RENC)
- to develop new model(s) perhaps by involving industry more directly

Other ENC Distribution-related Issues

Optional SENC Distribution of Official ENC's

At the 16th International Hydrographic Conference, a proposal was adopted that allows HOs to authorise the distribution of official ENC data in a SENC format [11]. This means that the ENC would be converted into the SENC format used in an ECDIS before it was sold, rather than being converted in the ECDIS onboard the ship. As an optional arrangement to be exercised at the discretion of each HO, this would be in addition to (not instead of) official ENC distribution. Authorised SENC versions of ENC data would most likely be performed by an authorized SENC data distributor under the control of the RENC or the supplying HO. The SENC distributor would be supplied with a master copy of the ENC from which the SENC copies would be produced.

Some of the reasons expressed for allowing SENC delivery as an additional method of official data distribution

include:

- ECDIS equipment manufacturers can be sure that ENC and SENC data's will operate correctly in their equipment
- use of official data will increase because SENC data can be used with both ECDIS and ECS systems.
- a SENC is by its very nature a secure data format that incorporates data integrity, access control and anti-piracy measures.

A number of IHO Member States do not support SENC delivery. Their reasons include:

- certain commercial ECDIS manufacturers will have an advantage over others
- how can SENC distributors assure HO's that the SENC data will be authentic and unmodified?
- SENC distributors may add their own data to the SENC
- ENC and SENC alternative distribution formats will confuse mariners

Production of "Small-Scale" ENCs

The WEND Principles make it quite clear that each HO should be responsible for the production of ENCs of its "waters of national jurisdiction". In this regard, most HO's have concentrated on producing "larger scale" ENCs of their ports, coastal areas, or major shipping routes. These generally occur within national jurisdiction or have been agreed through bi-lateral arrangements between adjacent nations. Agreement over production boundaries and access to data has generally been guided by following the long-standing practices for paper charts.

The issue of who will provide ENC coverage of international waters and waters beyond national maritime boundaries and the EEZ has been difficult to resolve. Australia and France have proposed that "small-scale" ENCs should follow similar arrangements to the production of paper INT charts. ENCs corresponding to small-scale INT charts would be produced by the same HO that produces the paper INT chart. Agreed production boundaries would have no political delimitation significance. Furthermore, for the smallest scales, no royalties would be sought for the use of data from other HO's. However, this concept has not been put into practice.

Looking to the Future

WEND was originally intended to have the status of an independent international organisation. However, it continues to operate as a Committee of the IHO. Since its establishment in 1994, the WEND Concept has resulted in the initial establishment of just one RENC for the Northern Europe region that in late 2001, sub-divided into two separate entities (NHS RENC and UKHO IC-ENC). No other RENCs have been established in other regions of the world.

Despite its limited success, the WEND Concept continues to be pursued through regional or bilateral cooperation arrangements between Hydrographic Offices in the IHO. The agreed concept defines the responsibilities and functions of HOs within a region necessary to develop, quality-approve, and issue the official ENCs for the use in ECDIS. This will also include the required updating services. Similar to what occurs for other types of nautical charting products and services, HOs will eventually need to be decided upon and establish a means for cooperation. A regional hydrographic commission within the IHO (e.g., the Caribbean – Gulf of Mexico Hydrographic Commission) would seem to be a logical place to start.

Recommendation: The MACHC – ECWG should establish a small Task Group to determine (or decide) which ENC distribution option would be most suitable for the HOs in the Caribbean – Gulf of Mexico Region.

References

- [1] IMO Performance Standards for Electronic Chart Display and Information System (ECDIS), IMO Resolution A.817(19), November 1995. International Maritime Organization, London.
- [2] Adoption of Amendments to the International Convention for Safety of Life at Sea (SOLAS) 1974, Revision to *Chapter V – Safety of Navigation*, IMO Resolution MSC.99(73), December 2000. International Maritime Organization, London.

- [3] Report of Special Committee on WEND. IHO Circular Letter 27/1994.
- [4] Hecht, Horst. 2000. WEND and RENC: Keywords for IHO's Distribution System for ECDIS Data – An Evaluation of Terminology and Concept. *International Hydrographic Review*, Vol. 1, No. 1 (New Series), p. 81-84.
- [5] Kerr, A.J. 1996. International Perspectives on ECDIS, *International Hydrographic Review*, LXIII (1). Monaco.
- [6] Wainwright, P. 2000. The Implementation of the WEND Concept: The PRIMAR Experience. *International Hydrographic Review*, Vol. 1, No. 2 (New Series), p. 55-61.
- [7] “NHS RENC Operational Proposal,” v1.2 – Expanded. Norwegian Hydrographic Service, Stravanger, 4 April 2002. [www.primar.org/stravanger]
- [8] International Centre for ENC: A Guide to the New RENC”, October 2002, [ic-enc.org]
- [9] Status Report on Virtual RENC Development in the MBSHC Area”, Report to 6th WEND Committee Meeting, 18-19 May 2001, [WEND Paper WEND/6/12a].
- [10] Ward, R. 2002. WEND Issues and ECDIS Data Distribution. Proceedings *GEOMATICA 2002*: IHO Workshop on ENC Production, 18 February 2002, Havana, Cuba.
- [11] Technical Resolution A3.11 – ENC/SENC Distribution Option, XVIth International Hydrographic Conference, 14-19 April 2002, Paper CONF.16/WP.3 Add2.

Prepared by:

Dr. Lee Alexander
Center for Coastal and Ocean Mapping – Joint Hydrographic Center
University of New Hampshire
Durham, New Hampshire USA
lee.alexander@unh.edu