

# AMERICAN SQUARE DANCE

Annual \$12

APRIL 1989

Single \$1.25



# HANHURST'S TAPE & RECORD SERVICE



## THE "ORIGINAL" SUBSCRIPTION TAPE SERVICE

*Have you heard all the  
75-80 releases that  
have come out in the  
last 3 months?*

*"I think you and your staff are doing a great  
job with the record service. You have pro-  
vided very responsive service when it comes  
to record ordering. Having both the tape and  
record service you provide, is well worth the  
expense." -- S.H., APO, New York*

*"I am quite impressed with the quality of the  
reproduction of the monthly Hanhurst tape."  
-- B.B., Alberta, Canada*

**The Continuing Choice of 1,300 Callers!**



**CALL TOLL FREE NOW  
FOR FREE SAMPLE TAPE**



**1-800-445-7398**  
(In N.J. 201-445-7398)

HANHURST'S TAPE & RECORD SERVICE  
P.O. BOX 687  
RIDGEWOOD, N.J. 07451-0687

**EUREKA   STING   SNOW   LOU MAC   BIG MAC**

ESP    CHAPARRAL    ROYAL    CHINOOK    RHYTHM    RED BOOT    BELCO    4-BARR-B    TNT

GRENN    CHICAGO COUNTRY    HAT    HI    PRAIRIE    EDHIDE    RAWHIDE    SEASHOULDER    RANCH HOUSE    STAR    BLUE STAR

# AMERICAN SQUARE DANCE

THE INTERNATIONAL MAGAZINE  
WITH THE SWINGING LINES

VOLUME 44, No. 4  
APRIL 1989



\*\*\*\*\*

## ASD FEATURES FOR ALL

- 4 Co-Editorial
- 5 By-Line
- 7 Meandering with Stan
- 11 Get Out Of Step
- 13 April Fool Fun
- 14 Dancing Daffy-nitions
- 15 The Anaria Sheikdom
- 19 The Late Great Square Dance
- 21 Name A Day—Or A Club
- 23 Vacation '89 (Events)
- 29 Encore
- 31 Hem-Line
- 35 Dandy Idea
- 36 Product Line
- 37 Best Club Trick
- 39 On Line
- 45 Party Line
- 47 Dancing Tips
- 51 Linear Cycle Around the Globe
- 55 Front Line Coverage
- 60 Linelight
- 76 People in the News
- 87 Bread Line
- 89 Puzzle Page
- 98 Dancing for Spectators
- 102 Disc-Count
- 106 Puzzle Answers
- 109 Book Nook
- 110 Finish Line
- 112 Laugh Line

## OUR READERS SPEAK

- 6 Grand Zip
- 41 Straight Talk
- 43 Feedback

## SQUARE DANCE SCENE

- 20 Late Callerlab News
- 58 A/C Lines (Advanced & Challenge)
- 70 Callerlab News
- 72 International News
- 93 S/D Mastercard
- 101 LSF Institute
- 104 Run To Oklahoma

## ROUNDS

- 33 Cue Tips
- 63 R/D Pulse Poll
- 79 Facing the L.O.D.
- 81 Flip Side/Rounds

## FOR CALLERS

- 49 Calling Tips
- 54 Easy Level Page
- 62 S/D Pulse Poll
- 64 Creative Choreography
- 68 PS:MS/QS
- 78 Steal A Peek
- 82 Flip Side/Squares
- 94 Underlining the Note Services

\*\*\*\*\*

## Publishers and Editors

**Stan & Cathie Burdick**

Member of NASRDS

National Association of S&R/D Suppliers

**American Squaredance Magazine** (ISSN-091-3383) is published by Burdick Enterprises. Second class postage paid at Huron, Ohio. Copy deadline five weeks preceding first day of issue month. Subscription: \$12.00 per year U.S., \$13.00 per year Can. & Foreign. Single copies: \$1.25 each. Mailing address: PO Box 488, Huron OH 44839. Copyright 1989 by Burdick Enterprises. All rights reserved.

## Editorial Assistants

Mona Bird	Mary Jane Connerth
Mary Fabik	Connie Maike
Bob Mellen	Jean Wright

## Workshop Editors

Ed Fraidenburg	Bob Howell
----------------	------------

Walt Cole

## Feature Writers

Harold & Lill Bausch	Bev Warner
Mary Jenkins	Ed Foote

## Record Reviewers

Frank & Phyl Lehnert  
Canadian Representative  
Orphie Marcellus

Sometimes inspiration just does not come easily, and the deadline approaches without the popping-up of a light bulb over the heads of the co-editors that signifies a great editorial idea. As the great monster Deadline loomed over our heads, we read a reprint in the bulletin from the Dixie R/D Council from a 1982 column by Carroll A Porter, then chairman of the Louisiana R/D Teachers Assn. Isn't it amazing how some words of advice are timeless? And how they apply to all facets of the activity, no matter the particular type of dance you are teaching?

"Let's consider the abandonment of such questions as, 'How many couples are in your basic class?,' 'How many couples did you graduate?,' 'Do you have a large workshop turnout?,' and 'How large is your club?'. These questions tend to suggest that quantity is all-important, which, of course, isn't so. It is what is done to, for, and with quantity to make quality that matters!

"The goals of the instructor should include a continual striving for dancers who dance well and with ease, while maintaining ethical behavior toward all others in the activity. Let all instructors think, talk and act in terms of quality. If your dancers made it through basics and have 'stood the test of time' in continuing to dance, whether two couples or twenty, you have succeeded and added to the activity.

"Thankfully, this is not a competitive pastime. Let us have *any* circles, just so they are filled with happy, competent

# CO-EDITORIAL



dancers, and led by ethical, competent instructors."

Here is our April Vacation Issue, with a slightly longer list of festivals and events than we published a year ago. Folks say that square dance tours are the best, because of the fun-loving and cooperative spirit that prevails. The same is true of square dance vacations. Try one—you'll like it!

The listings are all wrapped up this month in some fun articles and stories, because April starts off with a day of great humor. It has been said that we are not poor if we can still laugh, and that we lose something precious when we lose the ability to laugh at ourselves. We hope you'll enjoy the humor and carry your smiles throughout your April dancing.



Al Cannon  
Templeton, CA

#### RECENT FLIP INST.

- BM093 NO NO NORA/Mac
- BM092 JEEPERS CREEPERS/AI
- BM091 BELLS ON MY HEART/Ron
- BM090 EVERYBODY LOVES A LOVER/AI
- BM089 THANKS A LOT/Mac

## scope— big mac records

#### PRESENTS:

- BM094 TRAIN OF THOUGHT by Ron
- BM095 NIGHT TRAIN TO MEMPHIS by AI
- NEW HOEDOWNS
- BM1005 OLD JOE WHO/Ron calls Plus
- BM1006 CONNIE I./John Eubanks calls Plus
- BM1007 MARTY/Monty Hackler calls Plus



Ron Milneau  
Arroyo Grande, CA

#### ROUND DANCES

- SC37 CHALET POLKA
- SC36 NOW IS THE HOUR
- SC35 TOE TEASING
- SC38 HAPPY POLKA by Ken Croft  
& Elena de Zordo

SCOPE RECORDS P.O. Box 1448 San Luis Obispo California 93406



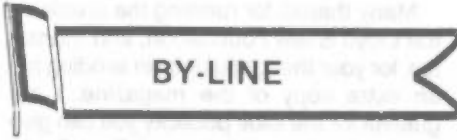

**BY-LINE**

Vacations and fun are the themes for this issue, and we have reprinted some features from other S/D publications because they carried out the theme so well or because they were so well-done.

**Al Eblen, Bill Barr and John Saunders** write about the square dance scene, in general. John's article appeared in Danny Robinson's *S/D Bulletin* in Florida and speaks well to a hot current topic. Humor is provided by **Marilyn Hill, Mary Stanley, John H. Dromey, David Stone** and a reprint from the *Four Corners Newsletter*. We hope the square dance spoofs give you a chuckle this month. **Bev Warner** has cleared her desk and sent a raft of articles recently. The first is included in "Bread Line." **Jo Jan Nunley's** tips on friendliness are included this month in "Dancing Tips."

Have a fun-filled April Fool's Day and a month full of good dancing!

- |                             |                            |                            |                            |
|-----------------------------|----------------------------|----------------------------|----------------------------|
| 1. Allemande Shop 78        | 25. Four Bar B Records 18  | 49. New England Caller 17  | 73. Meg Simkins 103        |
| 2. ASD Tours 59             | 26. Gold Star Video 82     | 50. N.E. Convention 12     | 74. Solid Gold Records 60  |
| 3. A to Z Engraving 16      | 27. Gr. Smoky Sq. Up 27    | 51. Nita Smith 104         | 75. Sophia T's 73          |
| 4. Authentic Patterns 98    | 28. Grand Travel 109       | 52. P-M-D-O Records 32     | 76. So. Cal. Callers 72    |
| 5. Bach. & Bachelorettes 72 | 29. Grenn Records 81       | 53. Palomino S/D Serv. 92  | 77. S/Dancers Closet 71    |
| 6. Badge Holders 67         | 30. Hi-Hat Records 83      | 54. Bill Peters 69         | 78. S/Dance Videos 20      |
| 7. Bermuda Convention 69    | 31. Hilton Audio Prod. 46  | 55. Promenade Shop 22      | 79. Steppin Out 42         |
| 8. Bermuda RD Conv. 100     | 32. J & J Upholstery 75    | 56. R&J Specialties 85, 96 | 80. Sue's Patterns 40      |
| 9. Blackwood Travel 80      | 33. Kalox Records 84       | 57. Ranch House Rec. 105   | 81. Supreme Audio 2, 112   |
| 10. The Catchall 101        | 34. Kirkwood Lodge 94      | 58. Random Sound 37        | 82. Swing Thru 111         |
| 11. Chaparral Records 30    | 35. Lee Kopman 97          | 59. Rawhide Records 44     | 83. TNT Records 73         |
| 12. Charmz-Reaction 74      | 36. Lasry Caller Supply 74 | 60. Rebel Records 55       | 84. Tortuga Exp. Tours 28  |
| 13. Chinook Records 99      | 37. Lightning Records 97   | 61. Red Boot Boys 11       | 85. Triple R West. Wear 48 |
| 14. Cimmaron Records 43     | 38. Don Malcom 73          | 62. Red Boot Prod. 10      | 86. Twelgenn 106           |
| 15. Circle D Records 43     | 39. Merrbach Rec.Serv. 107 | 63. Red River House 99     | 87. United Squares 63      |
| 16. Continental Squares 70  | 40. Micro Plastics 72      | 64. Rita's Quiltique 106   | 88. VeeGee Patterns 31     |
| 17. Dell Enterprises 29     | 41. Mid-Amer. Jamboree 50  | 65. Rochester Shoes 38     | 89. Venture Records 41     |
| 18. Double D Prod. 79       | 42. Mike & Barb's 75       | 66. Royal Holiday 36       | 90. Virginia Convention 77 |
| 19. Eagle Records 102       | 43. Miss. Festival 72      | 67. Royal Records 61       | 91. Wagon Wheel Rec. 6     |
| 20. Eddie & Bobbie's 62     | 44. Montreal Convention 34 | 68. Ruthad 45              | 92. Western Sq. Int. 85    |
| 21. English Mt. 56-57       | 45. Jack Murtha 95         | 69. Scope Records 4        | 93. Wisc. Convention 74    |
| 22. ESP Records 108         | 46. Mustang Records 93     | 70. Sea Squares 35         | 94. World S/D Conv. 52-53  |
| 23. Eureka Records 80       | 47. NASDC 106              | 71. Shirley's Shoppe 51    | 95. Yak Stack 95           |
| 24. Ed Foote 73             | 48. Nat. S/D Directory 92  | 72. Silver Sounds 103      |                            |

**ADVERTISERS LISTING**

For extra convenience to readers, we are listing our advertisers (space ads only) and numbering each. Readers should still write directly to advertisers as they wish, but any who desire information from several advertisers may circle the numbers to the left of advertiser's name on the blank and we will forward their requests to the proper businesses.

**This form invalid after May 15, 1989**

NAME \_\_\_\_\_

ADDRESS \_\_\_\_\_

CITY

STATE

ZIP

**CIRCLE** the number of each advertiser from whom more information is desired.

**Please mark no more than 20**

- |    |    |    |    |    |    |    |    |    |    |
|----|----|----|----|----|----|----|----|----|----|
| 1  | 2  | 3  | 4  | 5  | 6  | 7  | 8  | 9  | 10 |
| 11 | 12 | 13 | 14 | 15 | 16 | 17 | 18 | 19 | 20 |
| 21 | 22 | 23 | 24 | 25 | 26 | 27 | 28 | 29 | 30 |
| 31 | 32 | 33 | 34 | 35 | 36 | 37 | 38 | 39 | 40 |
| 41 | 42 | 43 | 44 | 45 | 46 | 47 | 48 | 49 | 50 |
| 51 | 52 | 53 | 54 | 55 | 56 | 57 | 58 | 59 | 60 |
| 61 | 62 | 63 | 64 | 65 | 66 | 67 | 68 | 69 | 70 |
| 71 | 72 | 73 | 74 | 75 | 76 | 77 | 78 | 79 | 80 |
| 81 | 82 | 83 | 84 | 85 | 86 | 87 | 88 | 89 | 90 |
| 91 | 92 | 93 | 94 | 95 | 96 |    |    |    |    |

# \* GRAND ZIP \*

Thank you for your note about "Date-Line listings; we would appreciate you listing it for us. We are transplants from Cleveland (Rocky River) and only wish we had known about square dancing the 28 years we lived there! We declare it's the world's best kept secret—and now that we have found out about it and belong to two clubs, we want to spread the word around that it's the *best* entertainment we have found. Three cheers for square dancing!

*Doris Keese  
Gretna, Virginia*

Just wanted to say thank you for using a picture of our dancers who went to Russia on your cover. My, how important we feel! My husband and I were square dancers in the group. It was an exciting trip and very interesting. The cathedral behind us is even more beautiful than the picture shows.

*Dot & Ron Smith  
Blue Bell, Pennsylvania*

How about some articles on clogging? I belong to Country Cloggers, Maroa, Illinois, and would enjoy more on clogging.

*Virginia Barlow  
Farmer City, Illinois*

Please add a few more items for single people in your magazine.

*S.D. Loring  
Garberville, California*

Many thanks for running the article on the Lloyd Shaw Foundation, and thanks, too, for your thoughtfulness in sending me an extra copy of the magazine. I am grateful for the wide publicity you can give our leadership workshop.

*Enid Cocks  
Manhattan, Kansas*

What a pleasant surprise to see our picture and the article in the January *ASD* concerning the special award we received from the Metropolitan New Orleans Area S&R/D Assn. It was a great honor to be chosen as the first to receive this tribute, then to be featured in *ASD* and on the cover of the *Louisiana State Assn. Newsletter*. All of this for something that has given us so many years of pleasure and the joy of meeting so many wonderful people. Thank you for giving us another happy memory.

*Johnny & Janie Creel  
Metairie, Louisiana*

...Now I have to tell you how great the magazine is. I love "Hem-Line," "A/C Lines," "Pulpollex,"—all the articles, even the advertisements. I'm sold on your magazine. We enjoy dancing every level and dance at least 20 nights a month. We dance with George Anderson, Chuck Stinchcomb and Bill Harrison regularly, and visit as often as we can, far and near. Would love to have you visit our Star Spangled Banner Festival held July 20-23, 1989...We'd love to read about it in Stan's "Meanderings." We are the new Adver-

**Continued on Page 100**



## WAGON WHEEL RECORDS

8459 Edmaru Ave., Whittier CA 90605 (213-693-5976)

### WAGON WHEEL EASY SINGING CALLS AND CONTRAS Basics 1-25

45 rpm flipp/inst. Calling by Bob Ruff

911 Gentle On My Mind	Basics 1-8	918 Glendale Train	Basics 1-19
912 Bad Bad Leroy Brown	Basics 1-8	919 Big Sombrero Contra	Basics 1-19
913 Engine 9	Basics 1-14	921 Shindig In the Barn	Basics 1-22
914 Hey Lei Lee, Lei Lee	Basics 1-8	922 King of the Road	Basics 1-9
915 If They Could See Me Now	Basics 1-17	923 Mississippi	Basics 1-25
916 Long Lonesome Highway	Basics 1-22	924 Houston	Basics 1-17
917 Robinson Crusoe	Basics 1-16	929 Shortnin' Contra	Basics 1-19

**SPECIAL FREE OFFER:** With your purchase of any of the above, we will include an equal number of records with Mainstream basics— FREE Call or write for a free catalog.



### A TALE OF THREE PRETTIES

A thousand and one pardons, folks! Last month I took all my special space to yuk and yack about Hawaii, ignoring completely a most festive fiesta in Canton on New Year's Eve. Let's go back a bit...

**Canton, Ohio**—The area council, including representative clubs, the Shirts and Skirts, Friendly □'s, and the Swing-alongs, booked me in a hall at Walsh College, where I had called on New Year's Eve once before. The *key-ordinator* was Larry Fecske. It was Carl and Pat Smith who cued. Cathie went with me, but she was fighting a cold, so she stayed in our motel close by, the Red Roof. I met caller Norm Brodie, who's as English as they come, by George! It was a classic year-end party—hats and noisemakers for all, pork and sauerkraut dinner at midnight, multi-balloon drop, door prizes, decorations—the works. Only one negative note—a road detour caused us to veer off to tiny Hartville in error, close to dance time.

**Freeland (Saginaw), Michigan**—Now Hawaii for us had come and gone; in spite of a touch of jet lag, I hit the road into mid-Michigan for a favorite encounter for NEMA in Freeland, set up by Dorothy Koelsch. 15 or 18 sets came out for fun

plus Plus. ASD staffer Ed Fraidenburg cued. (We'll bet you didn't know he cues.) Other callers/cuers present were Bill and Joann Towner, Jim and Marianne Senecal, and Fin and Juanita Burk. To quote an old saw from Saginaw—"I never met a Michigander I didn't like, from the youngest duckling to the old geesers." I'll be back next January. (After that remark, are you sure?"—Co-Ed.)

**Medina, Ohio**—Extremes of weather made a lot of difference in the crowd for the Medina S/D Club in early February. Instead of the ten sets that came out last July, we had only half that in the storm that greeted us this time. But that's the way the wind blows. Dance date publisher "Allemande Al" was there. So was innovator Jim Rensel (See ASD, Jan. '89, p. 91) and Andy Handy was handy for cueing. My contacts were Bob and Joyce Swarm from Hinckley, where buzzards flock. Banner swaps helped bring that club back to life with *sparkplugs* like the Freeses and others.

**Wooster, Ohio**—It was a glorious, festive evening with over a dozen sets, all dressed in red for the Gnat Boxers annual Valentine venture. (What fun for a sight caller.) Gary Zimmerman cued. Gene and Anita Butts were crowned King and Queen, and their names will go on a wooden, heart-shaped plaque honoring past royalty. Patty Bower was emcee. There were paper hearts on the wall of the big gym, a caller/cuer sign, a computer-generated welcome sign, red and white streamers, ice cream and cupcake snacks, and best of all—Roger Sherman in female-cupid garb, cavorting with a bow and arrow among the dancing sets. It was about as gallant as a gala can be in this whole galloping galaxy.

Hardly had we returned from heavenly Hawaii in January than it was time for me to leave chilly Ohio again to warm my toes in flowery Florida for almost a fortnight, not to mention Georgia and South Carolina on the same trip.

### **Port St. Lucie (Jensen Beach), Florida**

A whale-like Continental DC-9 took me with fins a-floppin' to Orlando, upon which I rented a natty Nissan and went hissinn' off to eastern shores. My hosts were Ted and Kay Fetzer, prexies of the Sandpiper S/D Club of Port St. Lucie. Ted is an interesting guy; a former pilot/trainer for Pan Am. We talked plane-ly. Just under the Jensen Beach arch sits the community cabin where we danced. Slight dusty floor but nice rustic atmosphere. Their regular caller for years was Al Brundage; John Venn founded the club. I met distant cousins George and Martha Burdick. There was Plus to pick us up, coffee to perk us up, and ice cream sundaes (after) before packing up and packing it in. Nice package, all around.

### **Fort Walton Beach (northwest panhandle), Florida**

—It was a long drive from P.S.L. to F.W.B. (Already I had clocked 500 miles.) but I had had two days in which to tick-clock-it, and made the intermediate stop in Tallahassee. From there, next day, the rest of the western panhandle was short to F.W.B. The evening started when my hosts, Conrad and Belle Bishop and a few friends dined at the elegant Liollios Restaurant overlooking the Gulf. Then we went to the PASARDA Hall, where the Belles and Beaux had set up the ASDance. Mid-February seems to demand a heart theme at dances everywhere, and it was a good *Valen-time* for all. Caller Ben Williams set the sound; caller Sid Hutcheson was also there; so were Joe and Joy Vaccari of USDA; Rose Lord cued rounds; prexies Kim and Mary Allen welcomed close to ten sets. Before the first birds chirped the next morning, I was up and tracing the big arc southward to lower Florida.

**Englewood (Venice), Florida**—It had been almost a ten-hour drive to Englewood in the lower handle of the gun-shaped state, but I rested a bit at Days Inn before Roy Hayden and Shirley Burnett picked me up for the Buttons and Bows dance at Lemon Bay H.S. Literally every-

one was dressed in red at this one. Fifteen □'s attended. Katie Beard cued, husband Gene loaned speakers. Prexies John and Lorraine Tallian presided. It was a treat to meet Lady Alma and Sir Harold Lamoreaux (active dancers, ages 84 and 86 respectively) who have danced at my dances from mid-Michigan to Key West. Therein lies a statement: thanks for their longevity, thanks for privileges of such friends we callers have, thanks for this world-wide activity that creates those friendships. The night ended with Pepsi, pepperoni pizza and antipasto at Angelo's. (Maybe you should be a little more anti pasta yourself; it's diet-time again. —Co-Ed.)

**Ocala, Florida**—It's always a pleasure to repeat in that cavernous City Auditorium (always on Tuesday) for the Ocala S/D Club, year after year. Thanks to Bob Rust for the first booking years ago. It was Valentine's Day and the floor was a sea of red. Refreshments were lavish. Andy (Trudy) Anderson had 'em queuing for the cues, as usual. Even Cupid couldn't have made 'em cuddle more cutely. George (Jean) Sinclair was emcee. My contact is Bob (Gladys) Weinspach. Mary (ASD staffer) and Bill Jenkins were there. A nice aspect of all Florida dances is meeting folks previously known for multi-years in multi-northern states and Canada. I'll be back February 20 in '90 and February 19 in '91.

**Arcadia, Florida**—From Ocala to Arcadia is just a short few hours' drive straight south, and it's always a treat to meet in Everett and Jennie Martin's cozy Promenade Palace S/D Hall. The crowd was choice and eager; Jennie cued; Everett (caller, builder, long-time friend) was emcee. Lavish eats; Hazel Stromnes made a Valentine cake; Dottie Earl made another for three who had birthdays; Jennie, Peggy Burnett and Joanne Mathis. Meanwhile, back at the Martin ranch, earlier, we had enjoyed the best steaks one of the Martins' Mama Brahmas could die for, and I'd die for another next year



about mid-February. (You mean no steak until next February?—Co-Ed.)

### GEORGIA 'N CAROLINA ON MY MIND

Two other states figured in this three-fourths of a fortnight February foray to Florida 'n further. Both Georgia and South Carolina were visited, too.

**AUGUSTA, GEORGIA**—Bless the land of peaches, pralines, peanuts, pecans and personable people! (Also preppies, Pepsi, preachers, prayerbooks and a president.—Co-Ed.) It was time for another visit to the CSRA Federation ASDance in that imposing and rustic Julian Smith Casino, along with another *steak-out* at the home of friends Dan and Mary Martin. In the rarified air of good S/D leadership, the Martins fly high! The makeup of the seven-set crowd called for calling a soft MS, since there were at least six couples of undergrads that night. Good fun, though. Jimmie and Libbie Nichols are CSRA presidents. Rounds were ably *maneuvered* by Hoover (Harold, not Herbert). Callers attending were Bill Prather, Don Ardrey and Gabby Baker; cuers attending were Marie Prather and Nell Knight. Same time, next year...

**Charleston, South Carolina**—This year the Belles and Beaus were the ASDance sponsors. It was still mid-February and the color red was predominant. Again this year, my spark-plug instigator friend, "Alex" Alexander, gave me a Chinese dinner and a speedy chase about town. Rounds are a big thing with this club: Bob and Jerrie Jones cued. Other cuers attending were: John and Mary Benthall, Jean Frenz, and Jack and Genie Whetsell. Callers present were: Jack Mattox, Merrill Ridgway and Brad Tomlinson. The welcome was from prexy Lib Way. It is a bit unique that both Bob and Jerrie cue equally well. In the *tossed salad* that makes up a typical club dance, the cueing was the topping, the calling was just so-so greenery. (Sounds as if the Jones were the spice and relish; you were more like *cue-cumbersome malaise dressing*,

not really worth your *celery*, Stan.—Co-Ed.)

### VERY MERRY QUERIES

#### GLEANED FROM THIS SOUTHERN SCENARIO

● How does Spanish moss get into the treetops that rise above all neighboring trees? (Maybe the answer is *Blowin' in the Wind*.—Co-Ed.)

● Why are they called Live Oaks? When they die (or are cut down) are they still called Live Oaks or are they called *Dead Live Oaks*? (That's an oxymoron.—Co-Ed)

● Do signs that say I-75 really mean *Increase to 75 MPH*? It would seem that way. Everybody does.

● I saw a sign near Tampa Bay that said *Bo-tel*. Is that a motel for boats? People, too? In Colorado I saw one that said *Horse Motel*. Do the nags have chocolates on their pillows at bedtime? Wakeup calls? (I thought a *Bo-tel* was for Mrs. Derek. Maybe also actor Bridges? And various pets?—Co-Ed)

● Why are Indian River oranges better than most in Florida? I like to buy a peck on each trip down there; eat 'em in the car for a week. Only this time I bit into a navel one day, chipped a tooth, and that episode turned into a very expensive *navel engagement!*

● Are folks really happy about living in Ashepoo, South Carolina? Or Coosawatchie? Do folks in Yee Haw Junction, Florida, ever shout a hee-haw yell? Are *busses* common in *Kissimmee*?

● I saw a sign that said "Turkey Shoot" and another that said "Ham Shoot." Ham Shoot? Kill all the porkers and who'd sniff out truffles? (Ham this column up much more and we may have a ham shoot right in the office.—Co-Ed.)

I can hardly believe it myself—my total mileage in that neat little Nissan throughout Florida, Georgia and South Carolina for just eleven days totaled 3,481 miles. That would be equal to going west from New York to Los Angeles, turning around and coming all the way back to Nebraska.

Gotta quit! Outta space! The End!





# RED BOOT PRODUCTIONS INC.

Rt. 8 College Hills, Box 28, Crest Dr.

Greeneville TN 37743

Phone: 615-638-7784

RED BOOT, RED BOOT STAR, GOLD STAR, J-K, G&W, ENGLISH MT.



Drew Scearce



Mike Hoose



Johnny Jones



Don Williamson



Wayne McDonald



Red Bates



Bob Barnes



Harry McColgan



T.D. Brown



Stan Burdick



Mike Callahan



Hoyle Grose



Steve & Jackie Wilhoit



Paul Kubier



Jim & Fae Park



Harold Rowden

- |     |      |                               |                |
|-----|------|-------------------------------|----------------|
| RB  | 3020 | IF THE SOUTH WOULD HAVE WON   | RBB            |
| RB  | 3021 | GONNA TAKE ALOTTA RIVER       | RBB            |
| RB  | 3017 | PINK CADILLAC                 | Don            |
| RB  | 3018 | HONKY TONK MOON               | Don            |
| RB  | 3022 | FOR THE GOOD TIMES            | Drew           |
| RBS | 1314 | SNOWFLAKE                     | Bob            |
| RBS | 1317 | CRAZY ARMS                    | Harry          |
| RBS | 1308 | THAT'S HOW MUCH I LOVE YOU    | T.D.           |
| RBS | 1302 | MY BLUE HEAVEN                | Stan           |
| RBS | 1293 | I'D DO IT ALL OVER AGAIN      | Mike           |
| RBS | 1318 | SOMEBODY ELSE IS TAKING PLACE | Hoyle          |
| RBS | 3015 | BLOWIN' IN THE WIND           | Red            |
| RBS | 1298 | THIS LAND IS YOUR LAND        | Ciiff          |
| RBS | 1310 | TENNESSEE FLAT TOP BOX        | Bill           |
| RBS | 1313 | I LIGHT THIS CANDLE           | Chuck Meyer    |
| RBS | 1311 | SENTIMENTAL JOURNEY           | Chuck Marlow   |
| EMR | 102  | COUNTRY SUNSHINE              | Harold         |
| RBS | 1316 | DON'T BE CRUEL                | Paul           |
| RBS | 1312 | PURE LOVE                     | Jim & Fae      |
| RB  | 912  | YOU'LL NEVER KNOW             | Steve & Jackie |
| RBS | 1319 | RIDIN' MY THUMB               | Don Coy        |



Cliff Brodeur



Don Coy



Bill Anderson



Chuck Meyer



Chuck Marlow



## GET OUT OF STEP

by Al & Nell Eblen  
Pharr, Texas

Did you ever know a good person whom you thought was a little strange? Peter Marshall, who was Chaplain of the U.S. Senate in the late '40's thought we should all be a little bit strange. Personally, I think the most wonderful people I know are "different." I certainly hope people think that I am peculiar.

Some people have told me that I am quite unusual, and I'm glad and take it as a compliment. I think many square dancers are strange and wish that all of them were.

Just what does *strange* mean? The dictionary says, "Differing from the ordinary." I hope someone thinks you are strange.

It is *strange*

To be truthful,

To be honest,

To be faithful to your spouse,

To not be envious,

Never to harm others,

To help your neighbor.

Wouldn't it be wonderful to be able to believe all that others say? It would be surprising if others were always honest and upright with you.

It would be so nice if no one ever cheated on his/her spouse.

We think people who are not envious are the nicest people in the world.

Wouldn't it be nice if no one injured others by accident or purpose or by word of mouth?

We think it would be great if all of us tried to help our neighbors. It would also be great if every square dancer worked for the good of the square dance club.

If you do these things, some will think you are strange. They will think you are out of step. Everyone we know who has done anything worthwhile or unusual has never followed the crowd. He doesn't do what "everybody is doing." He is a little strange and out of step.

Will you join us? Let's all get out of step...

# RED BOOT BOYS



## TRAIL-END DANCES

June 20— Tulsa, Oklahoma — 918-865-4414

June 21 — Oklahoma City, Oklahoma — 615-638-7784

## TAPES AND DATES

Write to: RED BOOT BOYS PRODUCTIONS

Rt. 5 Box 185, Blountville TN 37617



DANVERS  
THE SPIRIT OF  
MASSACHUSETTS  
**31st**  
New England Square &  
Round Dance Convention  
DANVERS, MASSACHUSETTS  
April 28 & 29, 1989

177 Callers and Cuers

14 Excellent Halls

All Levels of Square Dancing, Round Dancing and Clogging

Fashion Show with Delicious Luncheon

Special Events to entertain you

Trail In Dance, Thursday, April 27 at 8 PM

"Almost" Sunrise Dance, Saturday, April 29 at 7 AM

26 Shops Available for your Shopping Pleasure

Bus Service to all Halls and Camping Areas

Good Accommodations Still Available—  
—Both Hotel and Camping

For more information, call or write  
any of the Convention Chairmen listed below,  
or write PO Box 76, Danvers MA 01923

### WHERE IS DANVERS?

We are a tidal river port in case you want to sail in, or if you drive, we are intersected by Interstate Routes 1 and 95, also State Routes 62, 114 and 128. We also have our own Airport.

You can get here from anywhere,  
so join us for a wonderful weekend!

Danvers was once Olde Salem Village, where most of the witchcraft hysteria of the 1600's took place, so **Come Dance in Danvers** where witches once walked!

Registration will be at Masconomet Regional High School, Topsfield/Boxford line from 3 PM Friday and 10 AM Saturday.

**\$26.00 per Couple**

**\$13.00 per Solo**

**\$ 7.00 per Teen**

**\$15.00 per Fashion Show/Luncheon**

#### GENERAL CHAIRMEN

Andy & Louise D'Amore  
41 Fernwood Avenue  
Revere MA 02151  
617-284-3067

#### COORDINATORS

Gordon & Shirley Andersen  
13 Sheffield Road  
Danvers MA 01923  
508-774-4652

#### VICE CHAIRMEN

Bill & Angie Sutherland  
35 Roosevelt Avenue  
Dancers MA 01923  
508-774-1974

#### HOUSING CHAIRMEN

Ed & Carol Rudnicki  
11 Worcester Road  
Peabody MA 01960  
508-535-2137

#### CAMPING CHAIRMAN

Curt & Jackie Kimball  
PO Box 532  
Alfred ME 04002  
207-324-1656

#### FASHION SHOW CHAIRMAN

George & Nancy Haile  
5 Garden Street  
Beverly MA 01915  
508-922-0853

# APRIL FOOL FUN

*April is the month for humor, the time to enjoy a good laugh. Since the April file contained several good entries, we've opted for several good laughs this month, and so we combine several entries in this section.*

## MURPHY WAS A SQUARE DANCER

Murphy's Law applies very well to square dancing. Included are such laws as:

Perfect squares are doomed to fail when they square up in front of the caller.

Ice-cold water in the cooler is available only during the winter months.

The "good" dances are always scheduled while you are away on vacation.

You can bet the caller will call *yellow rock* if you eat onions.

Seams and hems never come undone before a dance, always at it.

Your favorite singing call is done during the tip you decided to sit out and rest.

You only make mistakes when your mother-in-law is watching.

Your boss at the office is your corner the day you call in sick.

Payday is the day after the local "big sale" on petticoats.

*From Four Corners Newsletter  
Cortez, Colorado*



The "Andyou" Sisters (Alex Stevens, Kelvin Love and Art Shepherd perform a tip for a Christmas Party at Cathedral Squares in Christchurch, New Zealand. *Mary Stanley*

## BERTHA FINDS A MATE

*by Marilyn Hill, Carrollton, Virginia*

All summer long the little town of Smithfield in eastern Virginia has been on the alert. A pet Caiman crocodile has escaped from his backyard pool. The authorities say he has an abundant food supply in the nearby swamp and by fall he could easily grow to six feet. Still he eludes capture. Will he be found? Here's what one dancer thinks:

It was Halloween night in Smithfield and our square dance club was having a costume dance at Smithfield Station. We were just about to square up when I walked Bertha Belcher with a date! This was a surprise! Now I won't say Bertha's ugly but some have said she looks like something that just crawled out of Cypress Creek. Dural Collins once offered to have his construction crew build her a man-trap because she was so desperate. The *Times* even had to stop taking personal ads because Bertha answered everyone in person. If there's a male on the loose in Smithfield, Bertha will find him. This time it looked like Bertha had hooked a good one.

Of course, we couldn't see his face, but he was tall, at least six feet, had nice green eyes, and the biggest smile I have ever seen. We started dancing and he moved through the calls with reptilian ease. He really seemed to like *dive thru* and *slide thru*. Bertha had never had so much attention in her life. He watched her every move almost like a predator stalking his prey. Once Robert Cox courteously asked Bertha to dance but her date hissed at him and chased him away.

Only one thing distracted him. Food. This guy inhaled a plate of Smithfield ham, then swallowed a whole roast turkey. Florine Moore almost lost an arm when she reached for a peanut at the same time that he did.

I asked Bertha how much she knew about this guy. She seemed a little evasive but she did say he's new in town and makes a living fishing. Then she had to run because they were going for a moonlight swim out at Burwells Bay. As they ran out the door, I saw something fall to the floor. I picked it up and saw it was a badge that read *Wally E. Gator, Caiman Squares, South America.*



# DANCING DAFFYNITIONS



by John H. Dromey  
Quincy, Illinois

*A Sequel to "Dancing Daffynitions"  
written by John in the April 1986 issue.*

**Accessory:** "Set" decoration.

**April Fool:** A dance instructor who one day a year gives grades to students based solely on the width of their shoes (A, B, C)

**Bolo:** String around the collar.

**Breakdown** (in communications): A dance that's "not on the level" advertised.

**"Clean" dancing:** Twirls, swings, and lariats—the "spin cycle" of the dance.

**Clogging records:** Trying to put too many in a small record case.

**Close call:** The kind you get when the calling's being done by someone who's also dancing in your square.

**Concrete example:** A dance demo given on a tennis court.

**Cuer in a crowded hall:** Leader of the "packed."

**Customs inspection:** Watching a native dance.

**Easygoing expert:** A dancer who's welcome in all the best circles, and squares.

**Exercise for health reasons:** Dance to your heart's content.

**Flying hair ribbon:** Accessory.

**Foreign exchange:** Swing your corner, while on an overseas junket.

**Going through a Phase:** Advancing in round dancing.

**Half a square:** A dance formation.

**Home run:** A much-faster-than-usual promenade.

**Icebreaker:** A caller who begins the first dance with a "hop," so nobody can possibly start off the evening on the wrong foot.

**Intermission:** Hoedown slowdown.

**Ladies' choice:** Same as the gentlemen—enjoy the dance.

**Lava leer:** Staring at a volcano.

**Lavaliere** (with microphone): Calling cord.

**Needlework:** Playing phonograph records, unless a live band has the job of supplying the dance music already "sewed up."

**No frills square dancing:** The absence of "lace" could mean that each time you kick up your heels a shoe flies off.

**One-sided-hit record:** Flip flop.

**Optimists:** People who dance their troubles away.

**Outdoor square dance:** Sun "set."

**Pessimist:** Someone who expects to find a sentry posted outside a "challenge" dance to keep away anyone who doesn't know the password.

**Promote square dancing;** "Set" a good example for others.

**Protest March:** What an impatient April Fool does.

**Quiet evening:** What a lady can expect at a dance when her partner is an unsuccessful prizefighter who's been conditioned by years of failure never to answer the "belle" after the first round.

**Raise the microphone:** An easy way to keep callers on their toes.

**Ready for "waves:"** Fit to be "tide."

**Round trip:** Traveling to a dance led by Irv and Betty Easterday.

**Set lag:** Delay in forming squares caused by convention goers forgetting to adjust their watches following a change of time zone.

**Sets sail:** What happens when square dancers go on a cruise.

**Snoregraphy:** A dance routine so boring it puts your feet to sleep.

**Square dancers on video:** TV set.

**Square feat:** Calling a big dance with a little microphone.

**Stealing another's moves:** Choreo graft.

**Symbolic gesture:** Going on a dance tour with a square suitcase.

**Three-quarter time:** Time to waltz over to the soft drink machine.

**Varied program:** Around the whirled in 80 ways.



# THE ANARIA SHEIKDOM

or  
Are We Squared Up Yet?

by David Stone  
Wichita, Kansas

Square dancing led young caller Sammy Novel and his wife, Cassandra, into some strange places, into interesting and exciting happenings.

Earl and Linda Linton, of the Dubloon Oil Company, were on vacation back in the United States. Linda dragged Earl to a one-night square dance party, kicking and screaming all the way, "No! I won't go!" And needless to say, Earl was hooked deeper than any fat ol' bass ever was.

"I understand you are a traveling caller and teacher," Earl said to Sammy.

"Yes, that is my cal--er-occupation."

"Would you be willing to take a vacation trip, of say three weeks, and teach a bumbling group to get off their couches and exercise their right to have fun?"

"You mean square dance?"

"Yes. In Anaria."

"I'll go almost any place to call or teach, if my calendar is not filled up."

"I have already checked with your beautiful child bride, Cassandra. She assures me that you have no large commitments that you can't break for a short vacation."

"Well, if she says —"

"Then it's settled. Next month you come to Anaria as a consultant in recreation to Dubloon Oil Company."

"Where is Anaria, what state —"

"I gave all the directions to Cassandra. Airline tickets will be ready tomorrow. Oh yes, you have to get a passport. I can rush



it through because I have connections."

"Passport, where is Anaria, anyway?"

And that is how Sammy and Cassy came to be in the Sheikdom of Anaria.

In just two weeks, every night and twice on Sundays, Sammy taught three squares of Dubloon employees how to square dance. During the graduation ceremonies, a long limousine pulled up to the Dubloon Rec Center. An Arab dressed in brilliant white dress or sheet, or whatever they call their robes, strode in.

"I am Abou ben Phun, Recreation and Entertainment Minister of Anaria. The Sheik will see you perform, today."

"But...", Sammy was flustered; he had just started the ceremony.

"No buts," Earl said. "When the Sheik calls, we go."

There was only room for twelve in the small limousine. One square, Sammy, Cassandra, ben Phun, and the driver went along.

Sammy and Cassy were introduced to Sheik Dull ben Bored, who sat, grimacing, on his throne.

"If I am not entertained by your dance, your lives will be forfeited."

"But...", Sammy tried to complain.

"No buts," said ben Phun. "What the Sheik wants, the Sheik gets."

Sammy hooked up his equipment with trepidation. The square formed and he began his patter.

Earl, being an enthusiastic new dancer, entered the dancing wholeheartedly. On the first *right and left grand*, he let out a "Whhoop" of enjoyment. And that triggered the excitement!

The Sheik gasped and squeezed the arm of his throne. The arm was designed so that such a squeeze would set off an alarm in the Palace Guard chambers. There were no guards there; this was a religious holiday for them. Only General Sheik Ghad ben Armed and Captain Will ben Led answered the alarm, the General with his ceremonial saber that would not cut paper, and the Captain with a relic

blunderbuss yanked from the Sheikdom Coat of Arms.

Hidden microphones picked up the loud, happy noise and transmitted it to the kitchen where the Sheik's Personal Food Taster, Tongue ben Burned, and the Sheik's Personal Cook, Chef Lam ben Roast, were working. The cook picked up his butcher knife. The taster grasped a shisk spit and wielded it like a bedouin charging into battle with a war lance.

All four defenders burst into the Sheik's chambers, two to a side!

The square dancers stopped in mid-step, each with a foot in the air.

Sammy almost swallowed his microphone; he might as well because he was dead, anyway, if that blunderbuss pointed right into his mid-section went off!

The Sheik held up his hand. He proclaimed. "Do not harm my guests. There has been no such merriment in my chambers in a long time.

"Ben Phun, get my wives and their handmaidens. I will join these merry-makers in their enjoyment."

"But, my Sheikhood, our religion forbids that men shall dance with women, or touch them during this religious holiday."

"I know, I know. The women can dance in one group, and the men in another."

But that didn't work out very well.

The Sheik sent to the harem for a bolt of veil cloth. Each woman wound her arms and head, beginning at one hand, wrapping around the arm, looping around head and face, and on down the other arm. There would be no actual contact as the man directed or led her. Of course, there would be no *yellow rocks*, which Sammy was famous for calling.

In each of the two assembled squares, there were two experienced dancer couples, a man with an inexperienced woman, and vice versa. Or was that verse vicea?

Sammy spoke the commands and ben Phun repeated them in his language. The Chef and Taster traded off occasionally as they prepared refreshments.

Sammy and Cassandra awoke, startled from the dream, in their own bed in Mid West City, U.S.A. They both recalled the four charging servant-protectors. They recalled the two very mixed squares. And the private luxury jet that flew them home.

"It couldn't have happened, could it?"

"Nah," Sammy answered his own query.

The ringing of the phone shook their reverie. There on the dressing table was a very long veil cloth. Puzzling over the cloth from the dream, Sammy answered the phone. "Hello?"

"Mr. Novel, this is Abou ben Phun. I want to thank you very much for the Callerlab T-shirt and the Cerified Caller Diploma. The Sheik has asked me to make arrangements to fly the whole National Convention over to Anaria at its completion. If not this year, then maybe the next?"

Have you seen anyone from the Dubloon and Palace Squares, or danced with them? Have you danced the *Sheikdom Anaria Two-Step*? No? Well, maybe in time.

The Sheik changed his name to Now ben Square and Round. Are you sure you haven't danced in his square at the national? Then maybe next year?



©  
**ORIGINAL ROVER BADGE**  
**CUSTOM ENGRAVING FOR CLUB BADGES**  
**RHINESTONE BADGES**  
**LONG-STRING MINI—PURSE (ass't colors)**  
**BUTTERFLY BELTS**  
**S/D ACCESSORIES — WRITE FOR CATALOG**  
A to Z Engraving Co., Inc., Since 1954  
1150 Brown St., Wauconda IL 60084 312/526-7396

# PRODUCTS of The AMERICAN SQUARE DANCE SOCIETY

These three colorful handbooks are a must for every dancer.

Now Marketed By:

**NEW ENGLAND CALLER, Inc.**  
P.O. Box 8069, Lowell MA 01853  
508-452-3222



1. **Basic/Mainstream Handbook**—450 illustrations. \$1.25 each, \$95.00 per hundred.  
SHIPPING COSTS BELOW



2. **Plus Movements Handbook**—32 pages, fully illustrated. 75¢ each, \$60.00 per hundred.  
SHIPPING COSTS BELOW

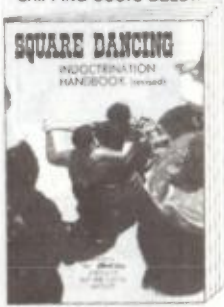

3. **Indoctrination Handbook**—Background, history, traditions—a must for every dancer. 75¢ each, \$60.00 per hundred.  
SHIPPING COSTS ►►►

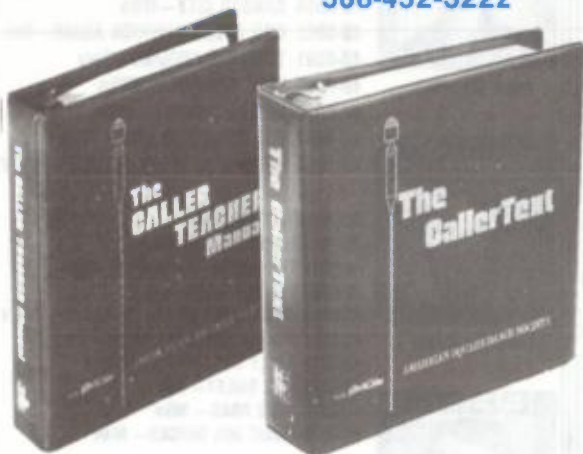

**The Caller/Teacher Manual**—This special guidebook covers the how-to-teach elements of calling. The Mainstream basics are covered with guidelines every caller needs to know. \$29.95 each + \$4.00 S&H.

**The Callertext**—640 pages. 100 authors, with important tips on how to be a caller. Virtually every phase of caller knowledge is covered in this marvelous volume. \$49.95 each + \$7.00 S&H.

Both volumes bound in quality, heavy-duty, 3-ring binders.

WE ALSO OFFER:	Single	Quantity	Shipping
Needle Notes Vol I	\$5.00		1-2 books
Needle Notes Vol II	\$5.00		\$1.25
Line/Solo Dance, Vol III	\$13.95		..... \$2.05
Diplomas—S/D	} .25 ea.	\$17 per 100 (Any Combo)	See below
Diplomas—R/D			
Archangel Certif.			
Appreciation Awards			
Calendars—5 year	\$4.95		\$1.75
Round Dancing For Fun	\$8.95		\$1.05

DEALER PRICES ON REQUEST

For Dealers Only—Quick Service—1-800-666-ORDER

### IMPORTANT—Add these SHIPPING COSTS (4th Class)

Basic/Mainstream Handbooks:		Diplomas, Awards & Certificates	
1 Book	\$ .75	19-39	\$3.00
2-5 Books	\$1.10	40-60	\$3.90
6-11 Books	\$1.50	61-100	\$5.00
12-18 Books	\$1.85		
<b>Plus &amp; Indoctrination Handbooks</b>			
1 Book	\$.50	9-36	\$1.85
2 Books	\$.75	37-75	\$3.00
3-8 Books	\$1.10	76-100	\$3.75
		1-9	\$1.05
		10-17	\$1.45
		18-33	\$2.15
		34-100	\$2.90

SHIPPING COSTS FOR USA ONLY — US CURRENCY ONLY

# FOUR BAR B/QUADRILLE RECORDS

"The Quality Sound"



Mike Sikorsky

**NEW RELEASES:**

- 4B-6098 WE AIN'T OUT OF LOVE YET—Bob F.
- 4B-6096 THE WANDERER—Gary
- 4B-6095 STRONG ENOUGH TO BEND—Paul
- 4B-6094 KANSAS CITY—Mike
- 4B-6092 GOD BLESS AMERICA AGAIN—Bob C.
- 4B-6091 TURN ME AROUND—Gary
- 4B-6090 LOVE REUNITED—Mike
- 4B-6089 W. LEE O'DANIEL—Bill
- 4B-6087 TOO GONE TOO LONG—Bob F.
- 4B-6086 WHEN YOU WORE A TULIP—Bill V.



Lee Main



Gary Mahnken

**RECENT BEST SELLERS:**

- 4B-6085 HAPPY TRAILS—Gary
- 4b-6084 THE TOP OF THE WORLD—Mike
- 4B-6083 I'LL FLY AWAY—Bill V.
- 4B-6082 DON'T BURY ME TIL I'M READY— Bill V.
- 4B-6081 KIDS OF THE BABY BOOM— Gary
- 4B-6078 SALLY GOODIN'— Otto Dunn
- 4B-6075 BILL BAILEY— Bob C.
- 4B-6073 DIXIE ROAD— Mike
- 4B-6070 MUSIC BOX DANCER— Mike



Bob Huff



Bill Volner

**NEW QUADRILLE RELEASES:**

- Q-861 DANCIN' SHOES— Art
- Q-860 HOOFIN' IT — Hoedown
- Q-859 JOLE Blon— Lee
- Q-858 OLD DOGS, CHILDREN & WATERMELON WINE—Ken



Larry Jackson



Bob Fisk

- Q-857 TRAVELIN' MAN—Bob H.
- Q-856 WALKIN' IN JERUSALEM JUST LIKE JOHN  
by Ken Burke
- Q-855 JUST LOVIN' YOU—Bob H.
- Q-854 BYE-BYE BLACKBIRD— Lee



Ken Burke

**RECENT QUADRILLE BEST SELLERS**

- Q-853 SQUARE DANCE TIME IN TEXAS— Bob H.
- Q-850 ANY OLD TIME— Lee
- Q-847 BIRTH OF ROCK AND ROLL— Larry



Paul Marcum

CALLERS GET-TOGETHER—Cassette Tapes Available

INTERNATIONAL DISTRIBUTOR FOR  
LLOYD SHAW FOUNDATION  
CONTRA & EDUCATIONAL RECORDS

Call or Write for our Free Catalogue.

**Box 7-11**  
**Macks Creek, MO 65786**  
**(314) 363-5432**



Art Springer



# The LATE, GREAT Square Dance

(When Did It Die and Why Wasn't I Notified?)

Written by John Saunders in *The Square Dance Bulletin*, Winter Park, Florida

Where Are the Crowds of Yesteryear?  
Is Square Dancing on a Downward Turn?  
What Caused It?  
Is the Activity Really Dying?

The question is always the same these days. *Is square dancing really dying?*" It is the question of the hour. What is even more interesting, most everybody's got an answer for the question!

Some answers are positive, some negative. Newcomers, not having experienced the years when square dancing flourished, tend to be more upbeat and enthusiastic in their answers.

For the record, the Late, Great Square Dance is still alive and kicking. And reasonably healthy. Square dancing is much the same today as it has always been—enjoying the high cycles, surviving the low, and enduring the in-between.

I'd like to say something about the downturn in numbers of dancers today as compared to ten or fifteen years ago. I am not sure there is as great a downturn as there appears on the surface. There was a big surge in numbers during the years when country-western was a big fad and western dancing was the rage. I believe this created a false sense that square dancing was going to continue to draw big crowds forever.

There were no indications prior to the country-western happening to give us a clue that a surge was coming or that it would last. When the fad peaked, subsided and then leveled off, there was a similar pattern happening in the square dance activity. I do admit that numbers of dancers do appear to be down today from five to ten years ago, but the numbers are up and the activity much stronger when compared to 20 to 25 years ago.

Think about this, there are more callers, more club programs, more SD/ camp/ resorts and more big weekend festivals to-



day than ever before. Are these the tell-tale signs of an activity dying out? Hardly. If anything, they are telling us the opposite. Put in perspective, the square dance activity is probably about where it would have been if we had never had the big country-western rage.

Square dancing is not dying. True, some negative opinions persist that the activity has one foot in the grave. But they were saying the same thing 20 years ago.

Square dancing has a lot going for it. Why do people do things together? People enjoy being with other people of similar interests, doing the same things. People like the sense of being successful at accomplishing goals. Many today are into physical fitness. Square dancing can and does fill all of these needs.

Square dancing is a very physical activity—an evening of dance can be the equivalent of walking over five miles. It also exercises the mind and reflexes. When moving to the music, dancing the figures gives the dancer a real sense of accomplishment and enjoyment that has no boundaries. As a square dancer, you can share a special kindred feeling with people who enjoy the same activity you do just about anywhere you travel around the world.

There are many positive sides to square



dancing and all these positive parts should be touched upon when selling the merits of the dance to our friends. We have spent too much time emphasizing only a few things like the low cost of the activity, fun and fellowship. All of us—callers, cuers and dancers—should strive to promote all the good points of square dancing, not just the same old ones.

And when dancing, instead of trying to impress people with our talents, let's strive to make others feel good about themselves...and be glad they know you. This type of attitude alone would say a lot about the merits of square dancing. It's time for all of us to take the lead in projecting and promoting this type of image for square dancing.

And what if that kind of image would spread? Wouldn't that be our greatest accomplishment? It is time to dispel the rumor—square dancing is far from dying. What it needs is a little coaxing from us—

## LATE CALLERLAB NEWS

Ken Ritucci, chairman of the Plus QS Committee, has announced that the recent ballot resulted in dropping the call *relay with a star*. Over 700 ballots were returned and the decision to drop was overwhelming with a 7 to 1 margin. The only Plus QS is *zip to a diamond*.

Damon Coe, chairman of the Advanced QS Committee, announced the choice of *lock the top* as QS for the current period. The calls *anything and cross* was voted to be dropped as an Advanced QS. The current Advanced QS are *counteract*, *shadow the column* and *lock the top*.

saying some good things about it for a change—to return to its former vitality.

Rest easy. I know for a fact that square dancing is not dead. If it had died, I would be the first to know it—Bob Barnes\* would have notified me!

\*Bob Barnes is a fellow Florida caller.

BUILD CONFIDENCE • SHARPEN SKILLS • REINFORCE LESSONS

# MAINSTREAM and PLUS PROGRAM VIDEOS



Callerlab Mainstream and Plus program videotapes. Filmed in television studio. Broadcast quality featuring overhead shots.

**MAINSTREAM**  
(Callerlab sequence 50-67)

**\$3995** (NJ res add 6% or \$2.40 per tape)

Featuring BETSY GOTTA, Caller, 25 years. Recording artist, featured July '87 Am. Sq. Dance Mag. Member Board of Governors, Callerlab

**PLUS**  
(27 movements)

**\$4995** (NJ res add 6% or \$3.00 per tape)



Outside U.S. add \$10. Specify "Payable in U.S. Dollars." Check or MO only.

© 1989, Tra Bien, Inc.

Add \$3.50 postage & handling. Please allow 2 to 4 weeks delivery.

Please specify  MAINSTREAM  PLUS  VHS  BETA

Mail check or money order to:

**SQUARE DANCE VIDEOS**

A Division of Tra Bien, Inc.

P.O. Box 1350, Maplewood, NJ 07040



Name (Please Print) \_\_\_\_\_

Address \_\_\_\_\_

City \_\_\_\_\_

State \_\_\_\_\_ Zip \_\_\_\_\_

AS

# NAME A DAY...OR A CLUB

From *The Roundup*, Minnesota

Did you ever get into a group discussion and pretend that you are assigned the task of coming up with another day for the week? What would you name that day and where would you put it?\*

When you are done thinking about that task, pretend that you are starting a new square dance club, and you are trying to find a name that hasn't been used yet. I have in my hand a copy of the *National Square Dance Directory*. In going through it, I have found that every name you would want and some you wouldn't want is already in use. Let me share some of these actual club names with you...

**Animals seem to be popular.** We have Unicorns, Grasshoppers, Bucks and Does, Honey Bees, Busy Bees and Single Bees. Brown Bears, Dancing Bears, Square Bears, Teddy Bears, Running Bears and Huggy Bears. Bull Dogs, Luv Bugs, Cougar Squares, Bobcats, Friskey Kittens, Top Cats, Hoot Owls, Barn Owls, Thunderbirds, Eagle Squares, Jolly Ducks, Bluejay Steppers, Penguins, Foxy Squares, Black Sheep, Polly Wogs, Sailfish Cloggers, Armadillo Squares, Dancing Dinosaurs, Horn Toads, Muddy Frogs, Moose Promenaders (Try that sometime!), Eager Beavers and Beaver Weavers (Try that, too, you could drop a stitch!)

**How about the names of square dance moves?** We have the Promenaders, Ocean Waves, Flutterwheels, Do-sa-do's, Star Promenaders, Wheels & Deals, Curli Q's, Acey Deucey's, Grand Squares, Cross Trailers, Gnat Boxers, Cloverleaf Squares, Peel Offs, and anyone else can belong to the Al'mand Left-overs!

**Until I looked in the book, I never knew there were so many ways to say that there are men and women in your club!** You've got the Bucks & Does, Elks & Does, Dudes & Dames, Dudes & Dolls, Dolls & Dandys, Guys & Dolls, Cowbells & Cowpokes, Cowboys & Cowgirls, Squaws & Braves, Bustles & Boots, Levis & Lace, Buttons & Bows, Shirts & Skirts, Pants & Petticoats, Ruffles & Rednecks,

Skirts & Flirts, Boots & Slippers, Buckles & Bows, Pants & Pantaloons, Boots & Cutes, Jeans & Queens, Toms & Hens, Toms & Tabbies, Hens & Drakes, Hicks & Chicks, Rebs & Debs, Mates & Dates, Paws & Taws, Lads & Lassies, Belles & Beaux, and finally Boys 'n Berries.

**You like cars?** You could join the V.W. Bugs, the Desoto Squares or the T-Birds.

**Pick a night of the week!** We have the Tuesday Niters, Tuesday Trippers, the Thursday Affair, Friday Squares, Saturday Night Dancers and the Sunday Affair. We also have the Sunday Steppers and the First Sunday Fiesta.

**How do they know when they have a good crowd** at the Phantom Squares?) or the Scrunch Bunch (I guess they always have a good crowd).

The Unicycle Squares could be a club to join after you have mastered all the Callerlab programs and you still need a challenge. The Rhythm Squares dance in a Catholic Church and you can make your own smart remarks about that!

**How about an old west flavor?** You can choose from the Buckboard Bouncers, Old Barn Dancers (is that the barn or the dancers?), Rusty Wheels, Ranch Hands, Chuckwagon Squares, Hay Makers, Wagon Train Squares, Wagon Wheels, Draggin' Wagons and Wagon Masters. If you are a Republican cowboy, there is a club called Reagan's Ranch Hands!

**All friendly groups,** how about the Hip Huggers, the Bear Huggers or the Yellow Rockers.

**Square dancers are a little nuts,** so we have Beach Nuts, Pinon Nuts, Sum-R-Nuts and Nutty Nuts. (Nobody has used Mixed Nuts yet.)

How about the Ebenezer Sets? (Bah humbug!), Hal's Pals, Claude's Clowns, Adam's Apples, also Apple Dumplings and Apple Squares.

**Here are some names that don't exactly inspire me to hurry to their dance:** Clod Hoppers, Fumblin' Feats, Goofers,

Who Goofed Squares, Stumble Bums, Hoofers & Goofers, Buck Leaguers, Hay Seeds, Stinkers, Dip Sticks, Two Timin' Squares, Poison Oakers, Odds & Ends, Stomp & Stumble Squares, Tanglefoots, Bad News Squares, Crazy Squares, Ding A Lings, Crackpots and Funny Farm Squares.

**People complain about too much violence on TV and in movies so they join a S/D club, but listen to these names:** Dynamite Squares, Swinging Hatchets, Melon Busters, Claim Jumpers, Bushwackers and Clutch Busters. It also looks like we will kick, stomp and trip just about anything that gets in the way when we want to square dance! Here are some examples: Hay Stack Kickers, Bronco Kickers, Lava Kickers, Dirty Devil Stompers, Hot Foot Stompers, Dixie Foot Stompers, Toe Stompers, Buckwheat Stompers, Corn Stompers, Big Hill Stompers, Barn Stompers, Barnyard Stompers, Steamboat Stompers, Village Stompers, Ridge Stompers, Acre Stompers, Stomping Saints, Salem City Stompers, Burley Twirlers and the Fishtail Whirlers.

**Want to clear a lake lot?** Get the Tall Tree Trippers, Tall Tree Twirlers and the Stump Jumpers.

**I guess we don't think much of cactus.** We have Cactus Dodgers, Cactus Kickers, Cactus Twirlers, Cactus Cuffers and Cactus Stompers! We also have Herford Whirlers and Chip Kickers. There is also a club called the Buzzin' Boots of which we would all be honorary members if we did all of the above! If there is anything left to stomp, we have one final club that doesn't specialize. They are The Stompers!

**We do have a few clubs that are non-violent:** The Relaxed Workshop, Graceful Squares and Sociable Squares.

**How about a space age name?** We have the Moon Spinners, Star Twirlers, Star Dusters, Star Spinners, Star Shooters, Star Steppers, Swinging Stars, Star Lighters, Southern Stars, Desert Stars and the Starlight Shufflers. We also have Cloud Hoppers, Rainbow Twirlers, Big Dippers, Sets in Orbit, Strato Jets,

Rockets and Dancetronauts.

**How about the Big Potato Squares and the Teen Spud Stompers or the Spud Shufflers** (shuffling them isn't bad, try dealing them or hiding one up your sleeve!)? The A Team, Chosen Few, Coffee Grinders, Cement Mixers and the Ten Mile Twirlers must have been a few of the last clubs formed and they were looking for names that hadn't been used yet.

**Finally here are some names that don't fit any particular category.** I will list them without any editorial comments; you figure them out. Oil Patch Promenaders, Helium Squares, Wiregrass Toe Tappers, Hassayampa Hoedowners, Goober Gamboteers, Hot Garters, Gay Notes, Tape Worms, Dust Devils, Prickly Pears, Hi Kicken Chickens, Grin 'n Square It, Cheese Town Squares, Neola Nee Nockers, Fallin' Arches, Swing Ding Dandies, Diddy Wa Dancers, Mug Wumps, Tommy Knockers, Whizzers, Boomerangs and Knobbers. (And we have the nerve to make fun of the names of the rock groups our kids listen to.)

If none of the above names appeal to you, how about these two? The Square Dance Club or No Name Club. If you still haven't made a choice, maybe your best bet is to forget about starting a new club and support the clubs we already have. Maybe they aren't so bad after all.

\*I'd call it Stretchday and put it between Saturday and Sunday to make the weekend longer, or call it Payday and put it between Friday and Saturday so we would have a payday every week but it would still be part of the weekend!

## FOR SALE

### Completely Stocked SQUARE DANCE SHOP

Same Location for 13 Years  
Owner Wishes to Retire

Great Opportunity for Caller & Taw  
or Square Dance Couple

### PROMENADE SHOP

4200 62nd Ave. N., Pinellas Park FL 34665  
Call: Days 813-522-4547. Nites 546-2071



#### APRIL

**1-2** Accent on Rounds, Green Lake WI. Write Ted/Doris Palmern, 3710 200th Av, Bristol WI 53104.

**5** Cactus Square Dance, YMCA, Huntington WV. Contact Marian Bowen, 304-523-3868.

**7-9** Weekend at Potawatomi Inn, Angola IN. Write Bill Peterson, 30230 Oakview, Livonia MI 48154.

**7-9** Winslow Fest 89, Bonnie Brennan School, AZ. Call Chuck/Elaine Griffin 289-5432.

**13-15** Myrtle Beach Ball, Convention Center, Myrtle Beach, S.C. Write Barbara Harrelson, 1604 Grays Inn Rd., Columbia SC 29210.

**14-16** Spring Festival of Rounds, Samia Ontario Canada. Write The Bartons, 464 East Av, West Hill Ont Can M1C 2W8.

**14-16** 14th Annual R/D Classic, Palm Springs CA. Write Palm Springs Parks & Rec Dept, PO Box 1786, Palm Springs CA 92263.

**21-23** 29th Annual Derby City Festival, KY Fair/Expo Ctr, Louisville KY. Write Jack/Marcia Hutslar, 44 Wildwood Dr, Jeffersonville IN 47130.

**21-23** Roaring Brook Weekend, Roaring Brook Resort, Lake George NY. Contact Dick Ellis, 4769 Woodwind Dr., Voorheesville NY 12186.

**22** Festival, Longwood College, Farmville VA. Write Wilson/Betty Adams, Rt 1 Box 195, Pamplin VA 23958.

**27-29** "Old Time Dancing" Conference, E. TN State Univ, Johnson City TN. Write Susan Spalding, E. Tenn State Univ, Box 19180A, Johnson City Tn 37614-0002.

**28** Plus/Class Dance Program, Riverheads Elem School, Greenville VA. Write Hedley Coffey, Rt. 1 Box 220, Greenville VA 24440.

**28-29** Gallia S/D Festival, Gallipolis Fairgrounds, Gallipolis OH.

**28-29** 31st NE S&R/D Convention, Danvers MA. Write Jerry/Selma Shulman, PO Box 1107, Lynnfield MA 01940.

**28-29** 25th Anniversary S&R/D Festival, Convention Hall Century II, Wichita KS. Write Sheldon/Sharon Lawrence, 436 Vassar, Wichita KS 67218.

**28-30** Fiesta Weekend, Albuquerque NM. Write Bill Litchman, 1620 Los Alamos SW, Albuquerque NM 87104.

**28-30** Spring Break Festival of Rounds, Pokagon State Park, Angola IN. Call Gloria Kilner (317)787-6548.

**28-30** 42nd Silver State S&R/D Festival, Reno-Sparks Convention Center, Reno NV. Write Donna & Chuck Bowlius, 10 N. Spring Mt. Circle, Sparks NV 89431.

**29-May 1** Square Dance Jubilee, London Bridge Resort, 1477 Queens Bay, Lake Havasu City, AZ 86403.

#### MAY

**5-6** 12th Annual Spring S/D Weekend, Renfro Valley KY. Write Ann Henderson, Renfro Valley Folks Inc, Renfro Valley KY 40473.

**5-7** Spring Jubilee A-2 Weekend, Ramada Inn, Keene NH. Call John Hendron (508)872-5904 or write Red Bates, 19 Hadley St #17, S. Hadley MA 01075.

**6** 21st Int'l S&R/D Festival, Univ. of Windsor, Windsor Ontario Canada. Write Jean Clark, 837 Bruce Av, Windsor Ont Canada N9A 4X6.

**6** Dandelion Delight II, Patrick Henry Comm College, Martinsville VA. Write Jim/Ann Chambers, Homestead Trail, Collinsville VA 24078.

**11-13** 14th Winnipeg Crocus Festival Inc, Univ of Manitoba, Canada. Write John/Lorraine Kozera, 869 Munroe Av, Winnipeg Man Canada R2K 1J3.

**11-13** 28th Int'l S&R/D Convention, McMaster Univ, Hamilton Ont Canada. Write Joan Fraser, 71 Roywood Dr, Don Mills Ont Canada M3A 2C9.

**12-13** Mountain-Town Hoedown, Riverside Motor Lodge, Gatlinburg TN. Write Pat Marlon, 1206 Oak Park, Maryville TN 37801.

**12-14** 30th Buckeye Dance Convention, Ohio Ctr, Columbus. Write Harold/Rosaline Raybern, 6661 Worthington-Galena Rd, Worthington OH 43085.

**12-14** Mid-America Round-Up, Wagoner OK. Write Bill/Vera Tolbert, 8214 E. 34th St, Tulsa OK 74175.

**12-14** May-Time Maneuvers, Coopers Plains NY. Write Dottie Griffiths, RD 1 Box 484, Hammondsport NY 14840.

**12-14** R/D Weekend & Improvement Clinic, Scottsdale PA. Write Al/Emily Bennett, 4954 Circle Dr, Export PA 15632.

**12-21** Ireland Tour. Write Al/Bea Brundage, PO Box 125, Jensen Beach FL 34958.

**14-21** Seaward Serenade, Cruise and Dance the Caribbean. Write Inspiration Cruises, 1551 E. Shaw, Ste. 107, Fresno CA 03710.

**19** Tulip Time Square Dance at Evergreen Commons Sr. Center, Holland, Mich. Contact John Rokks, 805 Meadowbrook Ave., Holland MI 49423.

**19-20** Natural Bridge Jamboree, VA. Write Phyllis Laflin, 1002 Courtland Av, Reidsville NC 27320.

**19-20** 11th Annual Cabin Fever Reliever Dance Weekend, Elko JHS, Elko NV. Write Betty/Phil Aranguena, 433 Sage St, Elko NV 89801-1386.

**19-20** May Magic Plus Level Festival, Anniston City Auditorium,

Anniston AL. Write Frank/Jean Norment, 308 E Third Av, Rome GA 30161.

**19-20** 2nd Annual Gatlinburg Spring Promenade, River Terrace Resort & Conv. Center. Write Fred Cole, 4900 Fury Way, Louisville KY 40258.

**19-21** Weekend at Potawatomi Inn, Angola IN. Write Bill Peterson, 30230 Oakview, Livonia MI 48154.

**19-21** NM S/D State Festival, Farmington NM.

**19-21** 34th Annual Spring Festival, Traverse City MI. Write Dan/Joanne Harrigan, 599 Keystone Rd, Traverse City MI 49684.

**19-21** Eastern Nebraska R/D Assoc Mayfest, Lincoln. Write Wendall/Ruth Robison, 510 46th St, Lincoln NE 68510.

**20** 9th Annual S/D Onion Festival, Sally Meadows Lunchroom, Vidalia GA. Write Willis/Rudell Dennis, 703 Clyde Blvd, Vidalia GA 30474.

**24** Dusty Trails Dance 6, Berea Fairgrounds, Cleveland OH. Write Cheryl/David Storgard, 9456 Sherwood Tr, Brecksville OH 44141.

**25** S/D Alaska Cruise on the *Westerdam*. Write Goliger's Travel, 360-900 Howe St., Vancouver BC Can. V6Z 2M4.

**26-28** Golden State Round-Up, Oakland Conv Ctr, CA. Write Bob/Betty Coates, 954 Northfield Dr, Hayward CA 94544.

**26-28** Chaparral Kansas City Convention, MO. Write Mary Campbell, 1425 Oakhill Dr, Plano TX 75075.

**26-28** Tennessee Childers Clinic, Montgomery Bell State Park. Write Ron Grendell, 544 Bell Rd, Antioch TN 37013.

**26-28** 3rd Annual International Cloggin' Jamboree, Novi Hilton, MI. Write Linda Summers, 14647 Bainbridge, Livonia MI 48154-3601.

**26-29** Papoose Pond C&D Weekend, N. Waterford ME. Call Joanne Mayo (603)329-5492.

**26-29** Mountain Fling, Camp Shadow Pines, Heber AZ. Write Larry Ingber, PO Box 1327, Sun City AZ 85372.

**26-29** Camp & Dance Weekend, Rocky's Rec Area, Boomville NY. Write Cliff Brodeur, Box 914, Pittsfield MA 01202.

**27** Cathedral Squares, Freshman's Frolic Cathedral College Gym, Christchurch New Zealand. Write Art/Blanche Shepherd, 49B Searells Rd, Elmwood Christchurch 5 NZ.

**30-June 9** Tour to Ireland and Scotland. Write ASD, Box 488, Huron OH 44839.

## JUNE

**1-3** 30th Int'l S&R/D Convention, Barnett Center, Aberdeen SD. Write Bob/Lucille Dreistadt, PO Box 345, Aberdeen SD 57402.

**2-3** Kansas State S/D Convention, Bicentennial Ctr, Salina. Write Lyle/Laura Reves, Rt 1 Box 44, Burlington KS 66413.

**2-4** 23rd Nat'l S&R/D Convention, Timaru, New Zealand. Write Marge Parker, 8 Moore St., Timaru New Zealand.

**4-11** Voyage of the Glaciers, *Regent Sun*. Write Sea Squares & Rounds, 8323 SW Freeway Ste. 800, Houston TX 77074.

**8-10** 25th Silver Festival, ISU Student Union Ballroom, Pocatello ID. Write Clair/Joan Layton, 702 Victor, Pocatello ID 83202.

**9-10** AlpenFest '89, Vail CO. Write Carl Kerns, PO Box 1171, Grand Junction CO 81502-1171.

**9-11** Bishop S/D Festival, Tri-County Fairgrounds, Bishop CA. Write Bill Gardner, PO Box 1677, Mammoth Lakes CA 93546.

24

**9-11** Spring Fling Weekend, Kingsmont West Stockbridge, MA. Write Cliff Brodeur, Box 914, Pittsfield MA 01202.

**10** Nat'l Asparagus S/D Festival, Shelby MI. Write Don/Margaret Knapp, 4435 W. Grant Rd, Shelby MI 49455.

**15-17** 23rd Annual Nat'l Mtn S/D & Clogging Festival, Natural Bridge State Resort Park, Slade KY. Write Richard Jett, PO Box 396, Campton KY 41301.

**16-17** 38th Annual WA State S/D Festival, Olympia WA. Write Festival of the Century, PO Box 512, Olympia WA 98507.

**16-17** 37th Annual S&R/D Festival, Bayfront Auditorium, Pensacola FL. Write Bill Jenner, 8121 Lillian Hwy Lot 82, Pensacola FL 32506.

**16-18** Advance Clinic/Dance Weekend, Kingston, Ontario, Canada. Write George/Pauline Morgan, Box H-166 RR 2, Sutton West, Ont Can L0E 1R0.

**18-20** Roundalab Convention, Oklahoma City OK.

**19** Circle D Records Trail Dance, Marshall TX Civic Center. Info: 214-693-5827.

**20** Trail Dance, Amarillo Civic Ctr, TX. Write Wanda Nobles, 1625 Stubbs St, Amarillo TX 79106.

**20** Circle D Records Trail Dance, Swingtime Center, Ft. Worth TX. Info: 817-763-8499.

**21** USA 89er Festival, Oklahoma City OK. Write Leroy Bolinger, Rt 1 Box 107, Gentry AR 72734.

**21** Circle D Records Trail Dance, Stevens Co. Fairgrounds, Duncan OK. Info: 405-785-2389.

**22-24** 38th National S/D Convention, Oklahoma City, OK.

**25-July 1** Kentucky Summer Folk Dance, Berea College, Berea KY. Write Kentucky Heritage Institute, PO Box 4128, Frankfort KY 40603.

**29-July 2** Leadership Institute, Canon City CO. Write Cal Campbell, 343 Turf Lane, Castle Rock CO 80104.

**30-July 2** 32nd Annual Jamboree, Thiel College, Greenville PA. Write Thad Karasinski, RD 1 Bank Rd, Conneaut Lake PA 16316.

**30-July 2** Independence Day Party, Hughsville Fairgrounds, PA. Write Eileen Williamson, 105 Lexington Av, Altoona PA 16601.

**30-July 3** 6th Annual Convention of the IAGSDC, Sheraton Centre Hotel & Towers, New York City. Write Skip Roglieni, PO Box 1229 Ansonia Sta, New York NY 10023.

## JULY

**3-9** Rocky Mtn Dance Roundup, Snow Mtn Ranch, Granby CO. Write Diane Burton, 20 NE 47th, Kansas City MO 64116.

**6-8** Festival '89, Mt. Boucherie Complex, Kelowna BC Canada. Write BC S/D Jamboree Assoc, Box 66, Penticton BC Canada V2A 6J9.

**6-9** Oregon Summer Festival, Oregon State Fairgrounds, Salem OR. Write 1989 Oregon Summer Festival, PO Box 12132, Salem OR 97309-0132.

**7-9** 21st Annual Leadership Seminar, Central WA Univ, Ellensburg WA. Write Virginia/Tom Nelson, PO Box 12027, Tacoma WA 98412.

**9-13** Procter Dancer Improvement, Dance Ranch. Write Frank Lane, PO Box 1382, Estes Park CO 80517.

**13-15** Annual Summer Fun Fair, Mt Vernon Fairgrounds, WA. Write Beverly Ruuth, 1471 Hwy 9, Mt Vernon WA 98273.

**14-15** Plus Level Festival, Anniston City Auditorium, AL. Write American Square Dance, April 1989



Harvey/Bettye Chambers, 4346 Angie Dr, Tucker GA 30084.

**14-16** Special R/D Weekend, Sarnia Ontario Canada. Write Beryl Barton, 464 East Av, West Hill Ont Can M1C 2W8.

**14-16** Cuers College, Stevens Point WI. Write Milt/Alice Spoor, 13325 W Burleigh, Brookfield WI 53005.

**14-16** R/D Clinic, Winston Salem NC. Write Phyllis Lafflin, 1002 Courtland Av, Reidsville NC 27320.

**14-16** 40th Annual S&R/D Festival, Show Low AZ. Write John/Gloria Locke, RR1 PO Box 282, Lakeside AZ 85929.

**14-16** 22nd OK R/D Assn. Annual Festival, Stillwater Write Arch/Helen Fisher, Rt 3 Box 44X, Duncan OK 73533.

**16-20** Procter Dancer Improvement, Dance Ranch. Write Frank Lane, PO Box 1382, Estes Park CO 80517.

**19-22** 13th Int'l R/D Convention, Convention & Civic Ctr, Detroit MI. Write Andy/Nancy Fry, 2444 Carriage Way, Ypsilanti MI 48197.

**20-22** 26th Star Spangled Banner Festival, Marriott's Hunt Valley Inn, Baltimore MD. Write Bill/Jean Toothe, 7215 Willowdale Av, Baltimore MD 21206.

**21-22** Thunderbird Clogging Festival, Mathis City Auditorium, Valdosta GA. Write Bob/Vivian Bennett, 2111 Hillcrest Dr, Valdosta GA 31602.

**July 21-23** A-1 Camp and Dance Weekend, Deer Run Campgrounds, Mechanicville NY. Contact Red Bates, 19 Hadley St. # 17, S. Hadley MA 01075.

**22** Johnston Jamboree Summer Special, Staunton VA. Write Cecil DePriest, 811 Opie St, Staunton VA 24401.

**23-28** TX R/D Teacher Training Institute, San Antonio TX. Write Don/Pete Hickman, 12118 Los Cerdos, San Antonio TX 78233.

**27-30** Square Dancing, Hunter Country Music Festival, Part I, NY. Write Guy Garraghan, Expo Planners Ltd, Bridge St, Hunter NY 12442.

**28-29** 36th Annual S&R/D Festival, Rushmore Plaza Civic Ctr, Rapid City SD. Write Al/Carol Horst, 613 Indiana St, Rapid City SD 57701.

**28-29** Weekend Festival, Univ of Scranton, PA. Write Brian/Geri Phillips, RD 1 Box 515, Olyphant PA 18447.

**29-30** S/D Weekend, Eagles Club, Lisbon ND. Write Kirt Skadberg, Box 62, Lisbon ND 58054.

**31-August 3** Callers College, Dance Ranch. Write Frank Lane, PO Box 1382, Estes Park CO 80517.

## AUGUST

**2-5** 27th Annual Overseas S/D Reunion, Western Hills Guest Ranch, Wagoner OK. Write Dick/Carole Manning, PO Box 414, Nicoma Park OK 73066.

**4** Sweden Tour. Write Al/Bea Brundage, PO Box 125, Jensen Beach FL 34958.

**4-5** 27th Annual S/D Festival, MS Coast Coliseum Convention Ctr, Gulfport-Biloxi. Write Harold Smith, 4502 Kendall Av, Gulfport MS 39501.

**4-6** 11th Annual Presque Isle Fun Fest, Edinboro Univ, PA. Write Harry/Meredyth Klein, 1971 Dewey Dr, Northeast PA 16428.

**4-6** Grand Smoky Square-Up, Grand Hotel & Conv. Center, Pigeon Forge, Tenn. Write Rt. 8 College Hills, Greeneville TN 37743.

**6-10** Callers College, Dance Ranch. Write Frank Lane, PO Box 1382, Estes Park CO 80517.

*American Square Dance, April 1989*

**6-12** Blue Ridge Mtn Dance Roundup, Copecrest, Dillard GA. Write Marie Armstrong, PO Box 1011, Canon City CO 81212.

**7-12** BC S/D Jamboree, Penticton Canada. Write Box 66, Penticton BC Canada V2A 6J9.

**17** Southeast Alaska Cruise. Write Goliger's Travel, 900 Howe St Suite 360, Vancouver BC Canada V6Z 2M4.

**18-20** Square Dancing, Hunter Country Music Festival, Part II, NY. Write Guy Garraghan, Expo Planners Ltd, Bridge St, Hunter NY 12442.

**18-20** 28th MI S&R/D Convention, Gardner Middle School, Lansing MI. Write Eldon/Mary Hall, PO Box 520, Merrill MI 48637.

**20-27** Seaward Swing Caribbean Cruise, Rawhide Buckskin Recording Staff, Write Inspiration Cruises, 1551 E. Shaw Ste. 107, Fresno CA 93710.

**24-27** 25th Jekyll Island Jamboree, Ramada Inn, GA. Write Bob/Vivian Bennett, 2111 Hillcrest Dr, Valdosta GA 31602.

**25-26** Montreal Area S/D Festival, Queen Elizabeth Hotel Write MASDA, PO Box 906, Pointe Claire Quebec Can H9R 4Z6.

**25-26** 21st Annual "Peach Festival" S/D, Mt Garfield Middle School, Clifton CO. Write Don Dodson, PO Box 1141, Grand Junction CO 81502-1171.

**25-27** 30th WI S&R/D Convention, Univ of WI, Stevens Point. Write Mike/Judy Hampton, 708 2nd St, Stevens Point WI 54481.

**25-27** 3rd Annual Summer Sounds Festival, Albuquerque S/D Ctr, NM. Write Wayne/Karen Sebrell, 6113 Torreon Dr NE, Albuquerque NM 87109.

**25-27** 2nd Annual Weekend, Hannibal Holiday Inn, MO. Write Tony McUmber, 1601 36th St, Hannibal MO 63401.

**26-Sept. 2** Caribbean Cruise Holiday, with N.Z. Kiwi Mt. Square Dancers. Write Blackwood Travel, 118 S. Elm St., Suite 101, Washington IL 61571.

**31-Sept. 2** 24th Annual Western S/D Festival, Natural Bridge State Resort Park, Slade KY. Write Richard Jett, PO Box 396, Campton KY 41301.

## SEPTEMBER

**1-3** 4th Annual Labor Day Jamboree, Erie County Fairgrounds, Hamburg NY. Write Lynnea Wheeler, 63 So Lane, Orchard Park NY 14127.

**1-3** Chaparral OK City Convention, OK. Write Mary Campbell, 1425 Oakhill Dr, Plano TX 75075.

**2-4** 21st Annual ASRDF Convention, Cochrane, Alberta, Canada. Write Fred/Elaine Henne, 9835 Auburn Rd SE, Calgary Alta Can T2J 1C9.

**8-10** Fall Frolic Plus Weekend, Kingsmont, W Stockbridge MA. Write Cliff Brodeur, Box 914, Pittsfield MA 01202.

**13-16** Myrtle Beach Ball, Convention Center, Myrtle Beach, S.C. Write Barbara Harrelson, 1604 Grays Inn Rd., Columbia SC 29210.

**15-16** 13th Annual Autumn Leaves Festival, Littleton HS, VT. Call (802)748-9122.

**15-17** Weekend at Potawatomi Inn, Angola IN. Write Bill Peterson, 30230 Oakview, Livonia MI 48154.

**20** Cathedral Squares Annual Dinner Dance, Univ of Canterbury. Write Art/Blanche Shepherd, 49B Searells Rd, Elmwood Christchurch 5, New Zealand.

**21-23** 28th Delaware Valley S&R/D Convention, Mt. Airy Lodge,

Mt Pocono PA. Write Darrell/Dottie Lewis, 42 Webb Rd, Chadds Ford PA 19317.

**22-24** 1st Indiana S/D Convention, Ctr, Indianapolis. Write Homer/Betty Jo Unger, RR 1 Box 355, Nineveh IN 46164.

**22-24** 2nd Annual Mtn Magic Dance Weekend, Snow Mtn. Ranch, Granby CO. Write Bill/Ann Root, 47890 County Rd 129, Steamboat Springs CO 80487.

**22-24** Plus Level Weekend, Old Orchard Beach, ME. Contact Red Bates, 19 Hadley St. #17, S. Hadley MA 01075.

**24** Buckwheat Dance Festival, Craig Civic Ctr, Kingwood WV. Write Frank Slagle, 100 Suartz Rd, Kingwood WV 26537.

**29-30** 3rd Annual Mid-America S/D Jamboree, KY Fair/Expo Ctr, Louisville. Call Clyde/Jean Elzy (502)368-1027.

**29-Oct.** 1 Starlite A-1 Camp and Dance Weekend, Stevens PA. Contact Red Bates, 19 hadley St. #17, S. Hadley MA 01075.

**29-Oct.** 1 2nd British National S&R/D Convention, Nottingham University. Write Keith Marshall, 31 Sunridge Close, Branksome, Poole, Dorset, England BH12 1PZ.

**30** Berkshire Community College First Annual Festival, Pittsfield MA. Write Cliff Brodeur, Box 914, Pittsfield MA 01202.

**30** Cathedral Squares Second Freshman's Frolic, Cathedral College Gym, Christchurch NZ. Write Art/Blanche Shepherd, 49B Searells Rd, Elmwood Christchurch 5, New Zealand.

## OCTOBER

**6-8** Chaparral Convention, Battle Creek, Mich. Write Mary Campbell, 1425 Oakhill Dr, Plano TX 75075.

**6-8** Empire State S&R/D Festival, Buffalo NY. Write Harold/Shirley Eck, 53 Harrison Ave., Delmar NY 12054.

**7** 50th Anniversary Dance, Denver CO. Write Dick/Jo King, 7101 W Yale Av Apt 3202, Denver CO 80227.

**13-14** Orange Blossom Special, Strawberry Square Hall, Plant City FL. Write Bob and Ginny Hallon, 206 Vine St., Plant City FL 33566.

**13-15** Catskill Country Weekend, Greenfield Park NY. Write Cliff Brodeur, Box 914, Pittsfield MA 01202.

**13-15** Weekend at Potawatomi Inn, Angola IN. Write Bill Peterson, 30230 Oakview, Livonia MI 48154.

**20-21** Atlanta Extravaganza, College Park, Georgia. Contact George Stanley, 23 Bay Ct., Riverdale GA 30296.

**20-22** Round-E-Vous R/D Weekend, Lord Stratford Hotel, Stratford CT. Call Joan Colippi (603)898-4604.

**20-22** Autumn Adventure, Dance Ranch, Estes Park, CO. Write Mike Kelly, 1701 W Spruce, Olathe KS 66061.

**20-22** International S&R/D Convention, Aranui HS Gym, Christchurch. Write Art/Blanche Shepherd, 49B Searells Rd, Elmwood Christchurch 5, New Zealand.

**22-29** Jubilee Jamboree Caribbean Cruise. Write Inspiration Cruises, 1551 E. Shaw, Ste. 107, Fresno CA 93710.

**27-28** Autumn Leaves Festival, Fontana Village Resort, Fontana Dam NC. Write Bettye Chambers, 4346 Angle Dr, Tucker GA 30084.

**27-29** Fall Frolic Weekend, Harley Hotel, Enfield CT. Write Al/Bea Brundage, PO Box 125, Jensen Beach FL 34958.

**27-29** Maple Leaf Weekend, Burr Oak State Park Lodge, Glouster, Ohio. Write Elsie Mills, 315 W Myrtle Av, Newark OH 43055.

**27-29** TN Barton Clinic, Montgomery Bell State Park. Write Ron Grendell, 544 Bell Rd, Antioch TN 37013.

## NOVEMBER

**3-4** Sioux Empire Hoedown IX S&R/D Weekend, Ramkota Inn, Sioux Falls SD. Write Kevin/Guylia Hohn, 2408 Judy Av, Sioux Falls SD 57103.

**3-5** Weekend at Potawatomi Inn, Angola IN. Write Bill Peterson, 30230 Oakview, Livonia MI 48154.

**3-5** Mystic Escape A-1 Weekend, Ramada Inn, Mystic CT. Contact Red Bates, 19 Hadley St. #17, S. Hadley MA 01075.

**5** United Squares of America Cruise on *Jubilee*. Call 314-391-7540.

**17-18** 25th Annual Roanoke Valley S/D Festival, Natural Bridge VA. Call Loren/Barbara Walker (703)387-3138.

**17-18** 27th Annual Mid-South S&R/D Festival, The Peabody Hotel, Memphis TN. Write Bill/Fran Tinnaro, 5263 S. Germantown Rd, Memphis TN 38125.

**17-19** New Festival, Kalamazoo Fairgrounds Complex, MI. Write Phil Kozlowski, 1531 Ebenezer Rd, Aurora IN 47001-1745.

**17-19** Mystic Adventure Plus Weekend, Ramada Inn, Mystic CT. Write Cliff Brodeur, Box 914, Pittsfield MA 01202.

**24-Dec. 6** New Orleans and Mississippi Queen Cruise. Write Jim & Gerrie Purcell, 340 Highland Ave., Randolph MA 02368.

**23-26** Thanksgiving Dance Weekend, Albuquerque NM. Write Kris Litchman, 1620 Los Alamos SW, Albuquerque NM 87104.

**23-25** 6th Annual National C.L.O.G. Convention, Opryland Hotel, Nashville, Tenn. Contact C.L.O.G. at 3452 Summitridge Dr., Doraville GA 30340.

**24-26** Maple Leaf Weekend, Niagara Falls Ont Canada. Write JoAnn Clow, 202 Chester Lane, Prospect Hts IL 60070.

**24-26** Funstitute, West Point, Thayer Hotel, NY. Write Al/Bea Brundage, PO Box 125, Jensen Beach FL 34958.

**25** Cathedral Squares Class of '89 Graduation, Cathedral College Gym, Christchurch NZ. Write Art/Blanche Shepherd, 49B Searells Rd, Elmwood Christchurch 5, NZ.

## DECEMBER

**1-3** Dynamo A-2 Weekend, Ramada Inn, Keene NH. Contact Red Bates, 19 Hadley St. #17, S. Hadley MA 01075.

**2** Cathedral Squares Christmas Party/Social Dance, Cathedral College Gym, Christchurch NZ. Write Art/Blanche Shepherd, 49B Searells Rd, Elmwood Christchurch 5, New Zealand.

**26** Winter in the Woods, Lake Cumberland, S Kentucky. Write Kentucky Heritage Institute, PO Box 4128, Frankfort KY 40603.

**HALLS AND RESORTS:** Following is a list of locations where a series of events are scheduled during the vacation season. Write for brochures and information.

**California**—David/Suzanne Abbott, PO Box 1720, McCloud CA 96057.

**Colorado**—Frank Lane's Dance Ranch, PO Box 1382, McCloud CA 96057.

**Colorado**—Fun Valley, Summer: Box 208, South Fork, Colorado 81154; Winter: PO Box 6547, Abilene TX 79608.

**Florida**—LeHigh Resort, 225 E. Joel Blvd., Lehigh FL 33936.

**Georgia**—Copecrest, PO Box 129, Dillard GA 30537.

**Illinois**—Royal Holiday, 1257 Franklin Lane, Buffalo Grove IL 60090.

**Michigan**—Bill Peterson, 30230 Oakview, Livonia MI 48154

**Missouri**—Kirkwood Lodge, box 37, Osage Beach MO 65065.

**Continued on Page 106**

*American Squaredance, April 1989*

# GRAND SMOKY SQUARE-UP

FEATURING

## THE RED BOOT BOYS

and other national recording stars

**GRAND  
HOTEL**

AND  
CONVENTION CENTER

PIGEON FORGE, TENNESSEE

AUGUST 4-5-6, 1989

SPECIAL ATTRACTION (SATURDAY NIGHT ONLY)

LIVE MUSIC BY STAN WILLIAMSON AND THE RED BOOT BAND

STEVE & JACKIE WILHOIT — ROUNDS

### PACKAGE

2 Nights at Grand Hotel (up to 4 in rooms)

4 Meals Per Person

Complete Square Dance Package

Ticket Package Only: \$15.00 Per Person in Advance, \$17.50 at the Door

Tickets to DOLLYWOOD with unlimited visitation available at Discount (Aug. 3-4-5-6)

2 Dancers in Room      \$200.00    No. \_\_\_\_\_ At \$ \_\_\_\_\_

3 Dancers in Room      \$235.00    No. \_\_\_\_\_ At \$ \_\_\_\_\_

4 Dancers in Room      \$270.00    No. \_\_\_\_\_ At \$ \_\_\_\_\_

Each additional Non-Dancer    \$20.00    No. \_\_\_\_\_ At \$ \_\_\_\_\_

Adult Dollywood Tickets    \$14.20    No. \_\_\_\_\_ At \$ \_\_\_\_\_

(12 & Over)

Child Dollywood Tickets    \$10.40    No. \_\_\_\_\_ At \$ \_\_\_\_\_

(4-11)

Total \$ \_\_\_\_\_

A Deposit of \$95.00 is due when you send Order Form. Balance, plus applicable Tenn. Tax is due by June 1, 1989.

Name \_\_\_\_\_

Address \_\_\_\_\_

City \_\_\_\_\_ State \_\_\_\_\_ Zip \_\_\_\_\_ Phone (    ) \_\_\_\_\_

Send Check or M.O. with Self-Addressed Long Stamped Envelope to:

GRAND SMOKY SQUARE UP — RED BOOT

Rt. 8 College Hills

Greeneville TN 37743

PHONE: 615-638-7784

Full Refund Through July 15  
10% Service Charge after July 15



**FOR SQUARE DANCERS,  
NOBODY KNOWS**

**HAWAII**

**LIKE WE DO...**

...and we'll give you real first-class treatment at the 25th Aloha State Square Dance Convention, **February 1-3, 1990** when you sign up to go to dance and tour with these popular callers/cuers:

**RED AND SHIRLEY BATES  
STAN AND CATHIE BURDICK  
RON AND CONNIE ROSS  
PHIL AND NANCY KOZLOWSKI  
RAMON AND JANE MARSCH  
RON AND SUZANNE HENSEL**

Enjoy an 11-Day, 3-Island ADVENTURE TOUR with PACKAGE AIR-LAND RATES, SPECIAL BANQUET, extra dances, workshops, SUN & FUN on the fabulous beaches Plus many extras/options.

HOW ABOUT A TRIP OR CRUISE TO THE CARIBBEAN, TO MEXICO TO THE CANADIAN ROCKIES, OR THE SOUTH PACIFIC?

**ASK US!**

*Tortuga Express Tour Co.*

**Toll Free: 800-323-2222 Nationwide/800-521-2346 Calif.**







# Encore

by Mary Fabik

*Highlights of Past Issues of this Magazine*

## 25 YEARS AGO—APRIL 1964

Al Brundage, who pioneered the square dance vacation concept, is the square dance director and coordinator for the upcoming New York World's Fair. Al's work with World's Fair square dancing is a first in the field. His promotion effort in this regard will have national effects as more and more people take part in square dancing.

Square dancers salute Al Brundage for his work with dance vacations and World's Fair square dancing.

—Excerpt from Editorial

This month, from the vacation advertisers, you can "treat yourself to an adventure" in Santa Rosa, California, with Manning and Nita Smith; have a fun-filled weekend at the beautiful Wisconsin Dells dancing to Johnny LeClair, Jim Brower...; combine Al Brundage's Funstitute with New York World's Fair at the Hotel Thayer, West Point, NY. or choose the Lighted Lantern S/D Camp atop Lookout Mt. in Colorado, featuring Tex Brownlee, Vaughn Parrish, Jon Jones...

"What have we, as leaders, to offer the

newcomer to round dancing? We must offer an evening of learning plus pleasure in accomplishment, classwork, fun and an opportunity to participate in a few of the easier rounds at club dances," write Kay and Ed Mack.

New Basic: *Swing and cross* by George Hales.

The first annual Rebel Roundup at Fontana Village, N.C., will be April 3-4. Top callers in the southeast will be featured.



Windsor Records presents *It's Almost Like Being in Love*, composed and called by Dave Taylor. The unique picture is from the Windsor ad.

## 10 YEARS AGO—April 1979

The biggest challenge of square dancing is not in mastering the C-1 list of basics; the basic challenge of getting along with others is the biggest one we

Continued on Page 97

# DELL Enterprises

Let DELL put our over 25 years of experience to work for you!

The Best in Badges & Buttons...

- CLUB and FUN BADGES
- Guest Visitation Badges
- Free Samples - Send Sketch for Estimate
- All orders pre-paid - Add \$1.00 postage

(619) 469-2109

1988 Square Dance Commemorative  
Pewter Buckles — Past Years Available



\$15.95 without color / \$19.95 with color

P.O. Box 364 ★ 7949 Broadway, Lemon Grove, CA 92045



KEN BOWER



JOHN & WANDA WINTER



BERYL MAIN



JERRY  
HAAG



MARSHALL  
FLIPPO



SCOTT  
SMITH



GARY  
SHOEMAKE

**NEW RELEASES**

- C-414 ZIPPITY DO DA—Beryl Main
- C-413 TAKES A LOT OF RIVER—Beryl Main
- C-708 SHINE—Marshall Flippo
- C-522 STREETS OF BAKERSFIELD—Ken Bower
- C-217 I'M GONNA SING—Jerry Haag
- C-216 WHO'S GONNA PLAY THAT OLE PIANO—Jerry Haag
- C-321 NEWTRON DANCE—Gary Shoemaker
- C-810 RISE AND SHINE—Scott Smith
- C-809 HELP—Scott Smith
- C-808 I'M GONNA GET YOU—Scott Smith

**1989 CHAPARRAL CONVENTIONS**

- May 26-28 KANSAS CITY, MISSOURI
- September 1-3 OKLAHOMA CITY, OKLAHOMA
- October 6-8 BATTLE CREEK, MICHIGAN

CHAPARRAL RECORDS, INC.  
 1425 Oakhill Drive, Plano, TX 75075  
 (214) 423-7389



Ernest and Estelle Clark of Savannah, Georgia, have been dancing for the past 25 years and currently are presidents of Round One Dance Club and members of Geechee Goofers and Country Twirlers Square dance clubs of Savannah and through all these years Estelle has sewed all of her outfits and some of Ernest's shirts and ties.

The outfit they model in the photo is a burgundy skirt and blouse. It was used as solid burgundy for quite sometime; the material is a polyester blend with satin ribbon effect woven in. The skirt is an eight gore down to the hem-line with a eight-inch ruffle over-laid. The ribbon effect on gores is vertical and the ruffle is horizontal. The blouse has puff sleeves with two rows of material ruffles, and stand-up ruffles at the neckline for a Victorian look. The skirt and blouse is blended together with a separate sash at the waistline. At a later time, Estelle added the white lace to give the appearance of a new outfit. The skirt and blouse are also used separately to make up other outfits. She uses a white crinoline and accessories to high light the white lace trim.

Ernest's shirt and pants were purchased in solid burgundy. The white tie and towel blend with Estelle's white accessories.

Estelle has also made and helped design club outfits and made individual ones to help promote and support the fun and fellowship they have enjoyed so much in square and round dancing.

# Hem-Line

by Bev Warner



**!!RECORDS!!**

**!!WORLDWIDE!!**

**ATTENTION: Callers! Teachers! Cuers! Dancers!**

**Need the name of a record supplier near you?**

**Interested in becoming a record supplier for your area?**

**WRITE TO:**

**TWELGRENN ENTERPRISES, INC.**

**P.O. Box 216, Bath, OH 44210**

**SERVING NORTH AMERICA AND OVERSEAS SINCE 1954**



Al Horn



Renny Mann



Johnnie Scott



Chuck Donahue



# PRAIRIE

Recordings  
Music by PRAIRIE

- PR1098 RIDIN' ON THAT NEW RIVER TRAIN by Renny (Just Released)
- PR1104 STREETS OF BAKERSFIELD by Renny
- PR1102 JONES ON THE JUKEBOX by Renny
- PR1101 SUN'S GONNA SHINE by Chuck
- PR1099 ADOBE HACIENDA by Johnnie



Mark Clausing



Tom Trainor



Kim Hohnholt



Ron Everhart



Jay Krebs



# Mountain

Recordings  
Music by Mountain Men

- MR75 CRYSTAL CHANDELIERS by Jay
- MR72 I'LL START BELIEVING IN YOU by Tom
- MR70 FISHERMAN'S LUCK by Mark
- MR69 AMERICA, AMERICA by Ron
- MR68 WHY NOT ME by Kim
- JOIN MARK CLAUSING AT English Mt. May 28-June 2 (Singles Week) with TIM MARRINER



Troy Ray



Hal Dodson



Amazin' Grace Wheatley



Frank Sanders



# DESERT

Recordings  
Music by Desert Sands

- DR40 LOVE IS A HAPPY SONG by Bill
- DR39 LADY OF SPAIN by Troy
- DR38 HAPPY HEART by Grace
- DR37 ON THE SOUTHBOUND by Hal



Dennis Levitt



Gary Bible



Len Dougherty



Jerry Thole

# OCEAN WAVE

Recordings

- OR27 JACKSON by Gary
- OR26 MAKES NO DIFFERENCE NOW by Jerry
- OR25 FOR ME AND MY GAL by Dennis
- OR24 LITTLE THINGS MEAN A LOT by Len



Kent Nyman



Mike Dabling



Wayne Crawford



Bob Main

- UR1 PITTSFIELD DRUM & BUGLE CORPS by Kent Nyman
- UR2 ONE FRIEND by Mike Dabling
- UR3 REACH OUT AND TOUCH A HAND by Wayne Crawford
- UR4 SHAME ON YOU by Bob Main

P-M-D-O RECORDINGS, 4270 W. 1250 S., West Weber UT 84401 (801-731-7222)



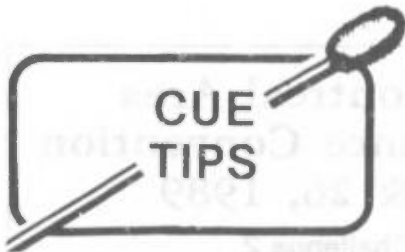

## KING OF THE ROAD

CHOREOGRAPHY: Anna MacDougall & Scott Cohen

RECORD: MGR 048, HH 892, BB 007

FOOTWORK: Opposite, except as noted

RHYTHM: Two-step

PHASE: II

SEQUENCE: INTRO AB AB ENDING

### INTRO

- 1-6 **WAIT; WAIT; CIRCLE FOUR;; PT STEP TWICE;;**  
(1-2) With arms outstretched fcg wall wait 2 meas;; (3-4) Circle away and tog snap fingers with each step L,—, R,—; L,—, R bring hands in,—; (5) Pt sd L arms out,—, cl L bring hands in,—; (6) Pt sd R arms out,—, cl R bring hands in,—;
- 7-10 **REPEAT MEAS 3 THRU 6**
- 11-14 **BASKETBALL PIVOT;; TWIRL TWO; WALK PICKUP CP LOD;**  
(11-12) Lunge sd L,—, rec R trng RF to face RLOD,—; Continue RF turn lunge sd L twd RLOD,—, rec R to face ptr & wall,—; (13) Fwd L,—, fwd R (W twirl RF R,—, L,—); (14) Fwd L,—, fwd R picking W up to CP fcg LOD,—;

### PART A

- 1-4 **TWO FWD TWO-STEPS;; PROGRESSIVE SCISSORS;;**  
(1-2) In CP LOD fwd L, cl R, fwd L,—; Fwd R, cl L, fwd R,—; (3-4) Sd L, cl R, XLIF (W XRIB) to SCAR fcg DLW,—; sd R, cl L XRIF (W XLIB) to BJO fcg LOD,—;
- 5-8 **FWD HITCH; HITCH SCISSORS; TWO TURNING TWO-STEPS CP LOD;;**  
(5) Fwd L, cl R, bk L,—; (6) Back R, cl L, fwd R (W sd RLOD R, cl L, XRIF to SCP fcg LOD),—; (7) Blending to CP wall sd L, cl R, start RF turn sd & bk L,—; (8) Continue RF turn sd R, cl L, sd & fwd R to CP fcg LOD,—;
- 9-16 **REPEAT MEAS 1 THRU 8 TO BFLY WALL**

### PART B

- 1-4 **VINE THREE TCH; WRAP; UNWRAP; CHG SIDES BFLY COH;**  
(1) In Bfly fcg wall sd L, XRIB, sd L, tch R; (2) Side R, XLIB, sd R, tch L (W trn LF L,R,L, tch R) keep both hands joined M's L and W's R hands over W's head & M's R and W's L hands at waist level; (3) Release M's L & W's R hands unwrap to arm's length step in place L,R,L, tch R (W unwrap RF R,L, R tch L); (4) Fwd R, fwd L, fwd R trng RF to bfly fcg COH (W fwd L, fwd R, fwd L trng LF to bfly fcg wall),—;
- 5-8 **REPEAT MEASURE 1 THRU 4 TO BFLY FCG WALL**
- 9-12 **FACE TO FACE; FWD TWO-STEP; FACE TO FACE; FWD TWO-STEP OP LOD;**  
(9) In bfly facing wall sd L, cl R, sd L trng LF to OP fcg LOD,—; (10) Fwd R, cl L, fwd R to bfly fcg wall,—; (11) Sd L, cl R, sd L to OP fcg LOD,—; (12) Fwd R, cl L, fwd R,—;
- 13-16 **CIRCLE AWAY & TOG;; TWIRL TWO; WALK PICKUP CP LOD;**  
(13) Circle away from ptr fwd L, cl R, fwd L to fcg RLOD,—; (14) Circle tog fwd R, cl L, fwd R,—; (15) Fwd L,—, fwd R (W twirl RF R,—, L,—); (16) Fwd L,—, fwd R picking W up to CP fcg LOD,—; (NOTE: 2nd time thru blend to SCP fcg LOD.)

### ENDING

- 1-11 **REPEAT MEASURE 3 THRU 13 OF INTRO**
- 12 **APT PT LEAD HANDS UP;**  
(1) Apt L,—, pt R and raise lead hands,—;

**CREDIT CARD VIA USDA**— Questions have arisen about the newly-initiated Silver MasterCard for square dancers and friends nationwide, which benefits the square dance activity via the United Square Dancers of America (USDA). ASD editors, after checking with Joe Vaccari, USDA committee member, assure you that this is a legitimate program, backed by a S/D organization of good standing. There will be an application in the center of our next (May) issue. Note the news article on p. 93.

# 14th Annual Montreal Area Square & Round Dance Convention AUGUST 25 & 26, 1989

## Mainstream to Challenge 2

*At the air-conditioned Queen Elizabeth Hotel  
in the heart of Montreal*

### SQUARES

Jerry Jestin, AL  
Lee Kopman, NY  
Ron Libby, ME  
Jim Lee, ON  
John Marshall, VA  
Rusty McLean, CT  
Don Moger, QC  
Dave Wilson, FL



### ROUNDS

Ralph & Joan  
Collippi, NH  
  
Phil & Becky  
Guenther, KY

REGISTRATION per person — \$22.00 Canadian \$20.00 U.S.  
per couple — \$44.00 Canadian \$40.00 U.S.

**NO REFUND AFTER JULY 20, 1989** Cancellations in writing only

MAKE BANK DRAFT OR CHEQUE PAYABLE TO — MASDA

MASDA, P.O. Box 906, Pointe Claire — Dorval, Quebec, Canada H9R 4Z6

For more information call: (514) 626-8107

### REGISTRATION FORM

(PLEASE PRINT)

OFFICE USE

Name \_\_\_\_\_  
Last Name His Hers

Street Address \_\_\_\_\_

City \_\_\_\_\_ Prov. or State \_\_\_\_\_

Mail Code \_\_\_\_\_ Telephone ( ) \_\_\_\_\_

### ACCOMMODATIONS Rates per night — minimum two nights

- |  |   |   |
|--|---|---|
| <input type="checkbox"/> Q. E. Hotel             | <input type="checkbox"/> \$86 Single              | <input type="checkbox"/> \$86 Double      |
| <input type="checkbox"/> Carrefour Dorchester    | <input type="checkbox"/> \$70 Alcove              | <input type="checkbox"/> \$78 Small suite |
| <input type="checkbox"/> Apt. Hotel (per couple) | <input type="checkbox"/> \$82 Large suite         | ( \$10 ea. add pers.)                     |
| <input type="checkbox"/> Camping                 | (Hotel rates are tentative and subject to change) |   |

Arrival Date \_\_\_\_\_ Time (approx.) \_\_\_\_\_ Dep. date \_\_\_\_\_

### PREFERRED DANCE LEVEL

Square MS  Plus  A1  A2  C1  C2   
Round SD  E  Int.  Adv.

## DANDY IDEA

### MORE BEAR FACTS

Beverly Barron's interest in bears began two years ago when she and Don Barron were married. Her daughter gave her teddy bears dressed in wedding attire and called them "The Bearons." Since one of Beverly's hobbies is writing stories and telling

them to children in church, she wrote a story about Grandma Bear, which was actually the story of how she and Don had been childhood sweethearts and then hadn't seen one another for almost forty years. They were both alone when they met again. They married two years later with her six grandchildren in the wedding.

Don introduced Beverly to square dancing and she loved it, so when he bought

her two more teddy bears for Christmas, she made square dance outfits for them. The Barrons became their club's presidents last July at a picnic where the bears made their public appearance wearing their presidents' badges. They have helped preside over all the Mohawk Valley Squares' dances during the year.

When an injury forced Beverly to give up a bookkeeping position, the bears came to the rescue and are helping her begin a mail order business featuring square dance apparel and accessories, and anything with bears she can find. She operates The Bearons Boutique, using the dancing bears in her advertisements.



## DANCERS & FRIENDS

### Sail ALASKA and Save

when you book early

**REGENT SUN**  
**Voyage of the Glaciers**

June 4-11, 1989  
with Dick Spooner & Earl Rich

**NIEUW AMSTERDAM**  
**Alaska's Inside Passage**

June 27-July 4, 1989  
with John Provini & Ed Rutty

Call Today For Information & Color Brochure

### SEA SQUARES & ROUNDS

8323 Southwest Freeway, Suite 800, Houston, TX 77074 (713) 771-1371

**OUTSIDE OF HOUSTON CALL TOLL-FREE**  
**1 - 800 - 523-6994**



*Flicker-Stickers*<sup>®</sup> transform sweats, evening dresses, purses, T-shirts, headbands, earrings, belts, boots, jackets, stockings and even skin. The possibilities are limitless. They can be hand-washed or easily removed, allowing you to change a look as quickly as fashion dictates. They are packaged in a handy, reclosable bag that contains more than fifty 1/5-inch chips.



**BRIGHTEN YOUR CORNER**  
Rhinestones, studs and sequins are always in fashion and right now they're hot, according to Tom Walker and Lee-Ann Larson.

*Flicker-Stickers*<sup>®</sup> are highly reflective metallic chips with pressure sensitive adhesive backs. They come in gold, silver, red, blue, green, pink and light blue. They require no special tools or time-consuming sewing; just peel off the back and press on.

For more information, call or write Tom Walker or Lee-Ann Larson, TW2 Inc., 2150 N. Lincoln Park West, Chicago IL 60614.

# ★ **Royal Holiday** ★

**SQUARE & ROUND DANCE WEEKENDS**

at *Pheasant Run* RESORT



## MEMORIAL DAY CLASSIC

**WADE DRIVER**

**TIM MARRINER**

**PAT BARBOUR, MIKE SEASTROM**

**Rds: Dave & Nita Smith**

**MAY 26-27-28, 1989**

Price per couple

2 to a room \$255  
4 to a room \$225

**TWO HALLS!**

Plus Level Dancing in Main Hall  
Separate Hall for A 1 & A 2 Dancing  
with Non Stop Catting

Pheasant Run is located  
on Rt. 64 (North Ave.) 3  
miles east of St. Charles,  
Illinois.

**DEPOSIT \$50 A COUPLE (A \$5 charge on all refunds)**  
Please make checks payable and send to: **ROYAL HOLIDAY**  
1257 Franklin Lane, Buffalo Grove IL 60090 Phone 1-312-634-0790





### Y SQUARES 25th ANNIVERSARY

It was a memorable celebration! Y Squares 25th Anniversary was held in November. Twenty four and a half squares gathered together to celebrate, with Bill Heyman calling. Bill was the recipient of Y Squares scholarship to callers school, in honor of Bob Kellogg, who, with his wife Jean, founded Y Squares in 1963. For 16 years Bob taught lessons, called squares and cued rounds for the club. When Bob died in 1979, Jean continued to teach and cue rounds. Jean was recently honored by Roundalab for 25 years service to round dancing.

On the 20th anniversary a covered wagon, made by Duane Hartline, left our club to travel in the square dance world. The wagon made its way to Canada, Australia, New Zealand and Germany. It returned home in time for our celebration, covered with badges of its travels and a list of names of our many square dance friends.



In honor of the 25th, several members of the club led by Rose Ericson made a special square dance quilt, which was raffled off during the dance. Each square of the quilt was a square dance couple in their finery or interlocking squares and circles, representing Square and Round Dancing. This is the fourth quilt made by club members.

During the 25 years, over 1500 persons have been members of Y squares. A good number of these dancers are still members of Y Squares, but many have moved on to other square dance programs. Club members look forward to their 30th anniversary with the knowledge that they will be there to help many more new dancers enjoy Mainstream dancing.

*Jean Koenig  
Cranford, New Jersey*

## CATALOG NOW AVAILABLE

ASHTON & CALIFONE AMPLIFIERS  
 ASTATIC & ELECTROVOICE MICROPHONES  
 CUSTOMIZED MUSIC VOLUME CONTROLS  
 SPEAKER STANDS (We manufacture)  
 RECORD SLEEVES  
 POLYETHYLENE RECORD STORAGE BOX  
 REPAIR SERVICE

NADY WIRELESS MICROPHONES  
 CALLER AND CUER CADDIES  
 3 AND 5-YEAR CALENDARS  
 MAGNETIC & TRAVEL PATTERN AIDS  
 NEEDLES, WAX, MISC.  
 TAPE RECORDING ACCESSORIES  
 AMPLIFIERS & MICROPHONES



### RANDOM SOUND, INC.

Oscar & Shirley Johnson  
 7317 Harriet Ave. S., Minneapolis MN 55423  
 612-869-9501 Bus./612-869-6168 Res.

**TOLL FREE ORDER NUMBER - See Below**

**SQUARE & ROUND  
Dance Footwear  
At DISCOUNT Prices**



the **SUBURBAN** for men

Only **\$19<sup>90</sup>**



Style "S"  
Reg. \$24.<sup>95</sup>

Color	Sizes	Width
Bone	7-12	Med.
Black	7-12	Med. & Wide

**A SELL-OUT AT THE ANAHEIM NATIONAL CONVENTION**

Light Weight • Cushion Insole • Soft Linings • Easy Care Manmade Uppers.

**Prancers**

Sizes: 4½ to 10  
Widths: N, M, W

STYLE D  
1st QUALITY!

Colors: White - Navy  
Black Smooth - Red  
Black Patent - Brown  
Gold - Silver - Bone



ONLY  
**\$23<sup>90</sup>** 1st Pair  
**\$21<sup>90</sup>** 2nd Pair  
( Same Size )

**"COAST"  
Ringo**



**\$29<sup>90</sup>**  
2nd PAIR  
**\$27<sup>90</sup>**

**THESE "COAST" STYLES**

**\$36<sup>90</sup>** Reg. to \$42.

**MISSY-style F** .....

**MANDY-style H** .....

**VICKI-style HH** .....



**"COAST" COLORS: White-Navy-Black-Bone-Red ( N,M,W Widths )**

**Call Our TOLL FREE Number  
1-800-255-1133 Ext. 310**

**OR MAIL TO:**

**rochester shoe stores**

8186 Pembroke Drive  
Manlius, New York 13104

Send with order:  
Style-Color-Size-Width-Price  
Your name, address, city, state, zip  
Add \$3.00 per pair for postage  
and handling. **Check, Visa,  
Mastercard Accepted**



## FOUR DOZEN USES FOR COMPUTERS IN SQUARE DANCING

by Nasser Shukayr  
Shreveport, Louisiana

Maybe you are already using a computer in your day-to-day life. Or, perhaps you've considered getting a computer, but you can't think of anything useful that can be done with it. Well, here's several dozen ways that a computer can be put to good use in the square dancing activity. The main idea is that if you spend less time on paperwork, you'll have more time to practice your calling or to learn the latest experimental basics!

### For both dancers and callers:

1. Membership lists for your square dance club or caller's association.

2. All the callers you've ever danced to. Why carry around a small convenient inexpensive little book, when a big bulky expensive computer system will do the same thing.

3. Birthdays and anniversaries.

4. Dance calendar. You can quickly find out when your favorite caller is calling in your area. Or, you can display all of the dances that are scheduled for this Saturday night, and decide which one you want to attend. Or, you can print out this month's schedule for your spouse.

5. Flyers. If you have a simple desktop publishing package, you can make some really snazzy flyers to announce your club's special dances.

6. Names, address, and phone directory.

7. Prospects for your club's next set of lessons. You can easily print a list of people that you want to call on the phone and invite to lessons.

8. Promotional information. You can simply merge your "student prospect" list with your "form letter," and crank out junk mail to your heart's content.

9. Table of contents for your cassette tapes. There just doesn't seem to be enough room on the little cassette to write down everything that you want to know about what's on the tape. With a computer, you can print out, in excruciating detail, the caller who is calling, the pattern record he was using, the date and time of the dance, the color of the dress your corner was wearing, et cetera.

10. Accounting. It sure makes it easy for the club's treasurer and/or secretary to prepare their written work on a computer. Of course, the first obstacle to be overcome is getting elected treasurer and/or secretary, but that's your problem and not mine.

11. Jokes. How many times have you thought of a punch line to a joke, but you couldn't remember how the joke starts? Or, maybe you remember how it starts but you can't remember the punch line. Well, what you can do is key in all the good jokes you've ever heard, and sooner or later you'll have a gigantic data file consisting of the world's funniest jokes. You'll be the life of any party. Personally, I myself have started a gigantic data file of funny jokes. They are all neatly catalogued and filed away in my computer, and numbered one thru eight. Oops, make that one thru nine. This paragraph is so darn funny that I'm going to catalogue it.

12. Callerlab lists of basics for each program. Whenever you have some spare time with nothing to do, just go over the list, and you can say to yourself, "I forgot how to do a *duxie grand!*"

13. Definitions and styling notes for each basic. You would refer to this file in the event that you forget how to do a basic (see previous paragraph).

14. Writing articles for *American Squaredance* magazine.

**For callers, keeping tabs on your calling activity:**

15. Blank contract forms. Anytime you need a couple of 'em, just mash a button and they'll be printed out before your eyes.

16. Calling dates (calendar).

17. Accounting. You can keep track of your mileage, expenses, income. It's not the most fun thing in the world, but it sure beats sitting in jail and wishing that you had kept better records.

18. Calling history. If you keep the proper records, you can easily review which songs you called for that strange club last year. That way, you won't have to listen to dancers saying, "He only knows seven songs." You can also review which gimmicks and cute patter figures you used last year, so that you'll know whether or not to use 'em this year.

**For callers, keeping tabs on your record case:**

19. Record listing. It's obvious, isn't it? Just make a handy little list of all the records that you have.

20. Singing call figures. You can put all of the singing calls from all of your square dance records into the computer. While you're at it, put in all of the singing call figures that appear in *American Squaredance* magazine each month. Then, you can do all kinds of neat things with this information. For example, you could print out all singing call figures which feature a certain basic that you are

planning to workshop.

21. Music selection. Just make a list of all the records that you might want to eventually get. Then, go over this list occasionally and pick out your top choices.

22. Record orders. Are you really in that much of a hurry to get your records ordered? Printing out your order and mailing it to the supplier saves time and expense, plus it reduces the possibility of mistakes being made.

23. Make a Record Listing for another caller. As a gesture of good faith, you can offer to make a printout for another caller of all the records that *he* owns. And, since your computer already knows what records *you* own, you can easily make a printout of the records you *both* have.

24. Lyrics to various songs. Why write 'em down when you can key 'em in and print 'em out.

25. Just for the fun of it, you can make a record listing of all the records that you own, sorted by the type of music (Country, Rock) and the decade (1960's, 1970's). Then if someone asks you if you know any 1950's Rock and Roll songs you can just whip out your handy computer list and select the proper record from your record case. Do you know what I wish? I wish that I could afford to buy so many records that I would need a computer printout just to tell me whether or not I know how to do a song. But, if you've already paid for the computer and for the records, well then why not have a little fun?

**Continued Next Month**

**NEW!**



**PATTERNS**

**NEW!**



Send \$1.00 for Pattern Catalog, Refundable on First \$10.00 Order or More

**SUE'S ORIGINAL SQUARE DANCE PATTERNS**

**3913 FORT AVE.**

**WACO, TX 76710**

**PH (817) 754-8645**



# STRAIGHT TALK

## MIXERS? —A SQUARE DANCERS' POLL

In a recent newspaper square dance article is this statement: "Friendliness seems to be a requirement for membership."

This poll was narrowed to senior citizen members, and the question, "Is it good for a caller occasionally to have a tip wherein the dancers will have a different partner?" The question was further qualified in two respects: 1. The caller announces the mixer firsthand before the dancers commit themselves, and 2. getting the new partner is one on some counting basis (*B-I-N-G-O!*) to avoid the awkward happenstance of being caught between two possible partners.

The poll carried in favor, and here are some reasons given:

A member dances with his or her regular partner one night a week? three nights a week? *seven* nights a week? Break it up a little.

Name tags. That square dancers wear name tags is great! But most tags (small letters) don't do a credible job. If you want to know who someone is, you still have to ask, "May I see your name?" Once you have danced a whole tip, however, it is easy for you to know and remember your partner's name. You are now acquainted!

In one of his movies, Fred MacMurray

worked for the Trotter Poll. "Just like the Gallup Poll," he explained, "except we're not in such a hurry! The report of a poll should give the number surveyed and an estimate of accuracy, so I had better do that. The number surveyed was one—me. Margin of error is plus or minus 100%. Anyway, we are like the Trotter Poll—I took a long time to make this report.

Donald Renner  
Dayton, Ohio

## WHERE IS OUR LEADERSHIP TAKING US?

I just received publicity material from the National S/D Convention with info about Youth Halls (That's fine.), Tours (That's fine, too.) Clinics (No convention is a convention without these), and Focus on Advanced and Challenge Dancing. No mention anywhere about Mainstream or Plus. My point is that they push too hard for the minority—the emphasis should be more on MS and maybe some on Plus.

Even the square dance clinics are a push to higher levels. Listed are "Introduction courses to A-1, A-2, C-1, C-2, C-3. Nowhere is there a clinic listed to further Mainstream.

I admit that most people believe that once they have graduated from MS lessons that they know all about it, but this is far from true. A good caller can keep even Advanced dancers challenged and entertained with good MS choreography. We should be working harder to keep dancers and callers aware of this.

Why keep pushing dancers out of  
Continued on Page 102



JERRY MITCHELL  
DeSoto TX 75115  
214-576-8715



NEW RELEASES

VR112 HEY BABY by Jerry VR111 LITTLE BIT IN LOVE  
VR109 YOU CAN'T BE A BEACON VR110 DO YA?

RECENT HOT RELEASES

VR108 Forever and Ever  
VR107 Can't Stop My Heart  
VR106 Corrine Corrina  
VR105 Walking the Floor Over You

VR104 That'll Be The Day  
VR103 Morning Ride  
VR102 Froggie Went A Courtin'  
VR101 Hip To Be Square



CHARLES QUISENBERRY  
Box 152, DeSoto TX 75115  
214-228-2559

The Prettiest in the Country . . . and the City!

# Steppin Out

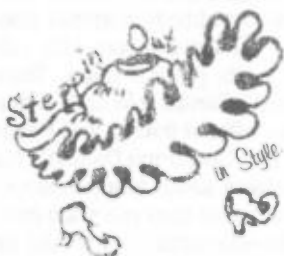

Fancy Square and Round Dance

## PETTICOATS AND CUSTOM DRESSES

**Made Better! Looks Better!  
Fits Better! None Better!**

**NYLON ORGANZA—A RAINBOW OF COLORS:**

Light pink, maize, hot yellow, apple green, forest green, lilac, medium purple, dark purple, wine, navy, aqua, black, white, red, royal blue, light blue, ivory, candy pink, cerise, dusty rose, kelly, peach.

### NYLON ORGANZA PETTICOATS:

20/20 double sweep (40 yards).....	\$47.95
25/25 double sweep (50 yards).....	52.95
30/30 double sweep (60 yards).....	56.95
30/40 double sweep (70 yards).....	64.95
40/40 double sweep (80 yards).....	72.95
60/40 double sweep (100 yards).....	87.95

### MATCHING PETTIPANTS:

Short leg, cotton & lace.....	\$10.95
Sissy (tennis) pants.....	11.95

**830 Wilson Rd.  
Humble, Texas 77338  
713-540-3557**

**WHOLESALE AND  
GROUP DISCOUNTS AVAILABLE**

Lamè and Twinkle also Available

**Mail order to: STEPPIN OUT ★ P.O. Box 398 ★ Humble, Texas 77347**

Length _____	Waist _____	Color _____	Name _____
Sweep (yards) _____		Price _____	
Pettipants _____		Price _____	Address _____
	Size _____	Color _____	
Postage \$3.00 each _____			City _____
\$6.00 outside USA _____			
Add Sales Tax in Texas _____			State _____ Zip _____
Check Enclosed \$ _____	Total _____		
C.O.D. _____			Please allow 2-3 weeks for delivery
Visa/Mastercard # _____			Expiration Date _____

# FEEDBACK

I find I must be in complete agreement with Karen Saxton and her "Teen Tempo." I attended the 1981 National Convention in Seattle—as a teen, but 19, so officially I was almost ineligible. Now I am 27, but I still dance with as much enthusiasm as I did then. I recall there being many "oldsters who were young at heart" in the teen room then, and I remember thinking, "I sure hope I can keep the spark as well as they!" Things *didn't* get out of hand, and yes, there were chaperones around. There is a place for them. But saying adults *can't* dance in the teen hall if that's the style of dancing they prefer is absurd. Who is saying that exuberant adults are poor role models for teens? If that's true, it will—literally—be a sad world when they grow up.

Sharon L. Roe  
Gardiner, Montana

Just finished reading "Teen Tempo" in September's issue. Frankly, I was more than a little bit "miffed" when I learned the Teen Hall was shuttered during Saturday's session. Reasons for its closure seem unclear and based on hearsay and/or petty jealousies.

The NEC should seek an alternative to its decision to eliminate the Youth Hall at future conventions. Failure to do so will deal our activity a major setback.

To alienate our youth or any other group is detrimental to the growth of square dancing. We must find solutions to our problems and promote the grow of our interest. Without such solutions, square dancing will not survive. *William Buck*  
Ozone Park, New York

*Ed. Notes:* We received several comments from NEC members that Karen Saxton's article was erroneous. The commenters were invited to send in the facts for publication. Nothing has been received.

**We hope to see you at these Circle D Records  
Trail-In Dances to the National Convention:**

- June 19—Marshall Civic Center  
Marshall, Texas (214) 693-5827
- June 20—Swingtime Center  
Fort Worth, Texas (817)763-8499
- June 21—Stevens County Fairgrounds  
Duncan, Oklahoma (405)785-2389

**For the Vacation of a Lifetime, Join Us at:**

- English Mountain, Tennessee      June 4-9, 1989
- Fun Valley, Colorado                  August 20-25, 1989

For Information, write or call:

6451 Oak Cluster ★ Greenwell Springs, LA 70739 ★ (504) 261-6143



Andy & Algje Petrere



Gerald McWhirter

## CIMARRON RECORD CO.

**NEW RELEASES:**

- C-109 RAGTIME PIANO
  - C-202 MOUNTAIN DEW/CIMARRON SPECIAL
- HOT SELLERS:**
- C-101 BAD BAD LEROY BROWN
  - C-102 THE PARTY'S OVER
  - C-102 HEARTACHES BY THE NUMBER
  - C-301 COL. STOCKADE BLUES, Jerry Rash

- C-401 RENO by Johnny Kozol
- C-108 I FEEL BETTER
- C-107 KINDLY KEEP IT COUNTRY
- C-104 SUGARTIME
- C-303 HONEYCOMB
- C-106 HONEYMOON FEELING
- C-302 TRUCK DRIVING MAN
- C-501 I SAW THE LIGHT



Jerry Rash



Bill Bumgarner

GERALD McWHIRTER, 4021 NW 61st., OKLAHOMA CITY OK 73112



DICK WAIBEL  
675 E. Alluvial  
Fresno CA 93710  
209-439-3478

# RAWHIDE RECORDS



JIM BROWN  
1121 Heritage Dr.  
Ridgecrest CA 93555  
619-448-4275



JERRY HAMILTON  
821 Madden St.  
Hemet CA 92343  
714-652-3442

- ★ HOT NEW RAWHIDE RELEASES ★
- RWH-156 THERE'S A TEAR IN MY BEER by Dick
- RWH-155 SINCERELY by Larry
- RWH-154 MR. RIGHT by Lee
- RWH-153 I COULDN'T LEAVE YOU IF I TRIED by Stan



LEE MCCORMACK  
Rt 6, Box 161A  
Mena AR 71953  
501-394-5913

- ★ COMING SOON ★
- RWH-155 SWIMMIN' UPSTREAM by Stan
- BUC-1232 SHE'S CRAZY FOR LEAVIN' by Steve

- ★ SIZZLIN' SELLERS ★
- RWH-152 STREETS OF BAKERSFIELD by Stan
- RWH-151 RAZZ-MA-TAZZ by Lee
- RWH-150 REAL GOOD FEEL GOOD SONG by Jim
- RWH-149 BABIES GROW UP TO BE COWBOYS by Stan
- RWH-148 IT'S A GOOD DAY by Larry
- RWH-147 I'LL NEVER BE IN LOVE AGAIN by Stan
- RWH-146 AM I BLUE by Jim
- RWH-145 TWINKLE, TWINKLE LUCKY STAR by Stan
- RWH-144 SOMEWHERE TONIGHT by Stan



STAN COLE  
5596 Valley View Rd  
Mariposa CA 95338  
209-966-5182



LARRY COLE  
3302 N. 500 West  
Marion IN 46952  
317-384-7089

- ★ PEPPY NEW HOEDOWNS ★
- RWH-515 BLACKJACK HOEDOWN by Stan
- RWH-514 FOXY FIDDLE HOEDOWN BY J. Hamilton

- ★ EXCITING NEW ROUND DANCES ★
- RWH-719 DARLIN' TWO-STEP by the Rows
- RWH-718 BABY'S GONE TWO-STEPPIN' by the Rows
- RWH-717 LOVIN' TWO-STEP by the Hamiltons



RAY TAYLOR  
Rd. #3 Box 216  
Bainbridge NY 13733  
607-563-2083

# BUCKSKIN RECORDS



AL SAUNDERS  
3001 S 288th Sp73  
Fed. Way WA 98003  
206-839-8970

- ★ HOT NEW BUCKSKIN RELEASES ★
- BUC-1231 THE GIRLS ALL GET PRETTIER by Ken
- BUC-1230 SWINGING ON A STAR by Ray
- BUC-1229 CUDDLE BUGGIN' BABY by Al
- BUC-1228 LOVE IS by J. Johnson

- ★ GREAT NEW HOEDOWN ★
- BUC-1512 BOOGIE BAM HOEDOWN by Al

- ★ SIZZLIN' SELLERS ★
- BUC-1227 MIDNIGHT HIGHWAY by Steve
- BUC-1226 YOU BELONG TO ME by Ken
- BUC-1225 JET SET by Ray
- BUC-1224 TOE TAPPIN' MUSIC by J. Johnson
- BUC-1223 OCEAN FRONT PROPERTY by Steve
- BUC-1222 BABY'S GOT A HOLD ON ME by Steve
- BUC-1221 MILLION DOLLAR BABY by Al



JERRY JOHNSON  
2119 Stirling  
Rapid City SD 57701  
605-343-4397

★ WRITE FOR YOUR FREE COPY OF OUR BRAND NEW CATALOG ★

QUALITY  
MUSIC  
FOR  
QUALITY  
CUSTOMERS



KEN SIERECKI  
5448 Wisteria Way  
Livermore CA 94550  
415-449-4492

★ DICK WAIBEL ENTERPRISES ★  
★ 675 E. ALLUVIAL, FRESNO CA 93710 ★ 209-439-3478 ★



### LET'S HAVE A PARTY

From an idea by Danny Robinson, caller for the Whirl and Twirl Club of Orlando, Florida, members set to work planning a Square Dance Party to recruit beginners. Members were cautioned not to tell their guests that they were going to a square dance but rather that it was a square dance party.

Incentives to members were three spectacular prizes. First prize was a complete dance outfit for gent and lady, donated by Dancin' Duds of Merritt Island, Florida. Second place prize was a dress and petticoat donated by King's Kid Cor-

ral of Orlando, Florida. Third prize, donated by the Whirl and Twirl Club, was 26 free admissions to regular club dances. Criteria for winning was simply to be the member bringing the most new couples into the beginning class.

Party night arrived and the square dance hall was filled to overflowing with members and guests. Danny called some square dances for demonstration, but primarily he called tips that everyone, guests included, could enjoy.

Numerous door prizes were awarded on party night, including free tickets to local attractions, certificates for free groceries, restaurant meals, plus the grand door prize of a set of beginner's lessons donated by Danny. The night was a huge success. The beginners class started the following week and many signed up. Several weeks later a club picnic, including all class members, concluded the affair with the announcement of the three lucky winners of the grand prizes.

Shirley & George Knapp

## PETTICOATS from RUTHAD, INC.

AL and ELEANOR MUIR 8869 AVIS (at ELSMERE) Phone: (313)841-0586 DETROIT, MICHIGAN 48209

### COLORED MARQUISSETTE PETTICOATS

Single Layer		Double Layer	
60 yards	\$35.00	50/50 yards	\$58.00
50 yards	\$32.00	45/45 yards	\$54.00
35 yards	\$28.00	40/40 yards	\$50.00
NOTE: White Marquissette		35/35 yards	\$46.00
Additional \$3.00 each		30/30 yards	\$42.00

### NYLON MARQUISSETTE RIBBON STRIPE

Colors: Yellow or Lime Green

Single Layer		Double Layer	
60 yards	\$45.00	40/40 yards	\$65.00
50 yards	\$40.00	30/30 yards	\$50.00

### NYLON ORGANZA PETTICOATS

Single Layer		Double Layer	
60 yards	\$51.00	50/50 yards	\$87.00
50 yards	\$47.00	45/45 yards	\$81.00
35 yards	\$45.00	40/40 yards	\$75.00
		35/35 yards	\$68.00
		30/30 yards	\$62.00

### NYLON SPARKLE PETTICOATS

Single Layer		Triple Layer	
50 yards	\$65.00	35 yards	\$50.00
50/50 yards	\$96.00	50/50/50 yds	\$144.00
45/45 yards	\$90.00	45/45/45 yds	\$135.00
40/40 yards	\$84.00	40/40/40 yds	\$126.00
35/35 yards	\$76.00	35/35/35 yds	\$114.00
30/30 yards	\$69.00	30/30/30 yds	\$103.00

Nylon Sparkle or Nylon Organza can be made reversible with each layer in a different color.

Triple and multi-colored petticoats available in all fabrics, upon request.

Multi: Single—\$4 extra; Double—\$6 extra

All petticoats are four tier unless otherwise specified.

### NYLON GOLD OR SILVER METALLIC

Single Layer		Triple Layer	
50 yards	\$94.00	35 yards	\$88.00
50/50 yards	\$129.00	50/50/50 yards	\$194.00
45/45 yards	\$124.00	45/45/45 yards	\$186.00
40/40 yards	\$112.00	40/40/40 yards	\$168.00
35/35 yards	\$105.00	35/35/35 yards	\$163.00
30/30 yards	\$99.00	30/30/30 yards	\$150.00

### LACE w/SILVER OR GOLD OVERLAY

50 yards	\$44.95	35 yards	\$39.95
----------	---------	----------	---------

### CHILDREN'S PETTICOATS—ORGANZA

With Cotton Elasticized Bodice

Size 1-2-10 yds.	\$16.00	3-4 Toddlers-15 yds	\$18.00
Size 3-4-10 yds.	\$18.00	20 yds.	\$23.00
Size 5-6-10 yds.	\$19.00	20 yds.	\$23.00
Size 7-8-10 yds.	\$20.00	20 yds.	\$24.00
		30 yds.	\$27.00
		30 yds.	\$28.00
		30 yds.	\$29.00

### STRETCH PANTIES

#### COTTON BATISTE, WIDE LACE

Colors to Match Petticoats

Leg Lengths: Sissy, Short 2", Medium 4", and Long 6"	
Small, Medium and Large	\$12.00
Extra Large	\$13.00
Gold or Silver Lace Trimmed	\$13.00
All Metallic Panties	\$16.00
Bo-Peep Pettipants (full length)	\$25.00
Lace Leg Warmers	\$12.00

We make any length special order petticoats, upon request.

Less than 19" and over 23" in length are

NON-RETURNABLE and NON-REFUNDABLE.

Shipping Charge \$3.00



**HILTON**

**MICRO-75B**

SOUND SYSTEM

**Plus**

**HC-8** COLUMN SPEAKER



Here's an all HILTON system that's hard to beat . . . The HILTON Micro 75B sound system, with variable speed turntable. Two microphone inputs, jacks for tape play back and recording. Compatible with wireless microphone systems, tape recorders and CD players. A very versatile system with enough power to cover those large workshops and classes. All of these features in a compact attractive case weighing only thirteen pounds. Built rugged and backed by the HILTON two year warranty. Combine this with the HILTON HC-8 column speaker and you've got a full system ideal for the workshop caller or round dance leader. The HC-8 utilizes two full size 8 inch extended range speakers and a passive radiator for increased bass response. Light weight, only 15 pounds, but will handle amplifier outputs up to 80 watts, with clean bass and brilliant highs.

Write or call for a literature package, with pricing, describing our complete product line of amplifiers, speakers, stands, microphones, record cases and Samson wireless microphone systems.

**HILTON AUDIO PRODUCTS, INC.**

1033-E Shary Circle • Concord, CA 94518

Phone: (415) 682-8390



## Dancing Tips

### HOWDY HOW-TO'S OF A SUCCESSFUL CLUB by Jo Jan Nunley

Depending on your club's situation, square dance lessons are in full swing, winding down or maybe your club is just gearing up for lessons. All clubs, no matter what their situation, have one thing in common. That is the gnawing question: Can we keep our new members, our old members, and encourage other dancers needing a club home to choose us?

Successful clubs do this because they have discovered a necessity for their ongoing success. It's called "howdy power," which boils down to just good, old-fashioned friendliness.

In addition to a love for dancing, way back when some of us took our lessons, there was another underlying reason why we chose square dancing. We wanted to meet new people. If we were lucky enough to choose a club with Howdy Power, we did meet new people and make lasting friendships.

But as the years creep by, we find we know many dancers at the dances we attend, and then we become lazy. We don't make the effort to cultivate new friendships with the new square dancers who make their way through lessons.

Sometimes clubs inadvertently encourage this because lessons and club dances are held at different times. Although this practice has its merits, I do believe it puts a distance between current club members and the people taking lessons.

Many dancers fall into the pattern of dancing with the same friends each time they dance. Many times it's an unconscious attitude. We drift to familiarity instead of fording new waters.

My husband and I had a direct ex-

perience with this when we took some Plus lessons. One evening we walked into a square to make the unwanted fourth couple. The three couples already assembled were from the same club. We had only been standing in the fourth slot a short time when the fourth couple from their club came and stood by us. The hint was clear. They came as a club, and they intended to dance as a club.

Clearly, any club would want to discourage this type of behavior. Later that same evening, two couples from that square made it a point to come join us and dance in a square with us. We felt their embarrassment over the situation. And, to us, no harm was done.

Still, we did feel some stigma from the occurrence. New dancers might have felt more slighted than veteran dancers. The end result, the most drastic one that all clubs hope to avoid, might have been a couple of fine dancers dropping out of that club or out of dancing altogether.

How to avoid such happenings? The answer to this sticky problem must come from each individual dancer. Make a deliberate plan to be a greeter for your club.

Being a greeter, that is speaking pleasantly and passing the time with each and every person you meet, sounds easy to some. For many, and I admit to being among this group, conquering the monster, Shyness, must come first. Vanquishing Shyness, which could become a killer in a club, takes deliberate work. Fortunately, success can be yours.

Plan to be an active greeter for your club for just *one* night. The old method used by dieters and others with problems works with shyness also. Conquer it for just one day. Today.

After increasing your greeting power for one night, you probably will find you had such a great time that you will want to incorporate it every time you dance. Everyone will be a winner.

A method I found effective years ago when I was in a speech class and had to give oral book reports was that instead of speaking as my self at the podium

**Continued on Page 75**



Spring Rainbow  
of Colors!



"SPRING  
BOUQUET"



**Spring Package**  
Dress-Petticoat-Pettipants  
**\$110.00 (Save \$14.50)**

**Style TR-511**

A rainbow of color in white, pink, lilac, aqua and yellows! A delightful new Spring fashion. Multi ruffle neckline and hemline, using alternating bands of pastel plaid with coordinating color sheer and floral print. A pastel beauty! Sell print tie belt. Washable. Sizes 6-20.

**Style TR-511 \$75.00**

A perfect Spring match in your favorite pastel color of White, Pink, Blue, Aqua and Lilac or Yellow in our popular new "Light and Airy" petticoat. Triple layer construction of nylon net sandwiched between two layers of nylon parchment tricot. Leaderline in the attractive binding trim contributes to its 60 yd. fullness. Length and waist adjustable top. Sizes: P S M L.

**Style M-565 \$39.50**

Matching pettipants (specify nylon sissys or poly cotton Pettis) P S M L XL. **\$10.00**



Special One-Time Cutting  
Get your orders in Early  
Won't last Long  
March-April delivery



Send with order:  
Style, Color, Size and Price. Your Name,  
Address, City, State and Zip. For Charge:  
Card Number and Expiration Date.

Add \$5.50 for postage & handling. \$6.50 for Air Mail. Check, Visa and MasterCard accepted.

Please allow 3-4 weeks for delivery.

Send \$3.00 for a copy of our Square Dance Apparel Catalog. Will be refunded with your first order.

**"The Best Little Square Dance Store Around"**

**250 West Broad Street (Route 7) Falls Church, VA 22046  
(703) 534-7273**



# Calling Tips

by Harold & Lill Bausch

In the January 1989 magazine, I mentioned that not all clubs are—or can be—labeled strictly MS or Plus. One caller wrote in to chastise me for that statement. In his letter to me, I read that he has attitudes much as mine, but that he did not understand what I was trying to say. I suspect he was not the only caller to misunderstand my ideas, so I had best clarify.

I stated that callers must use their own judgment at times and cannot accept an exact limit, as the Callerlab programs specify. Let me tell you what I was trying to get across.

In metropolitan areas where there are thousands of dancers and maybe fifty or sixty clubs in a small area, I believe strict MS and Plus must be observed. At the same time, we must realize when we talk of square dancing as a whole that there are more clubs in this country that are not in metropolitan areas. Where the setting is more rural or the towns are small, one or two clubs must serve a large area. The dancers in these areas want the fun of doing many calls but cannot support MS, Plus and Advanced clubs in their limited areas. They know of other calls and perhaps have been exposed to them at festivals and conventions or have read them in this magazine. They want to try these calls, too, so they keep after local callers to teach them and call them.

We know that all callers try to give the dancers what they want, and we know that the callers must use judgment and know when too much is too much. Many rural areas, and I must include cities of under 30,000 in this category although some may dislike it, do not label their clubs at all, simply because they refuse to be limited.

Callers say, then how are we to know

what to call? May I suggest they do as I do and visit with the club officers beforehand. Ask what is being called and what is not. It doesn't take long to get a good grasp of what they are doing. Also some clubs are wise enough to put up a list of calls they are using.

A problem just as big is to know if a club listed as Plus is a full Plus DBD or maybe a full Plus standard position. I have found Plus clubs, too, that break down on some MS variety. Putting a label on a club does not tell you all a caller needs to know.

We know too that when a club asks you to do a Plus Tip that you have the same problem. Some will expect a challenging Plus; others will expect you to just use some of the Plus calls. Have you ever started a Plus tip (or MS) expecting to "free wheel" and use sight to resolve the squares when you wish, only to find that not one of your pilot squares could handle your calls? Do you then fall back on pre-memorized calls? Do you workshop? As a caller, you are making decisions so fast that you should be a computer, except that computers do not yet think.

Judgment! What a big word! What an important part of calling! In my next callers' school, I have resolved to spend more time on trying to teach judgment. Speaking of this subject, I suggest callers use judgment in another field—teaching classes. As the years go by, I find I teach calls in a different sequence than I did years ago. I find, too, that I have learned to combine calls to teach. For example, to teach *scoot back*, I combine *turn thru* and *fold*. I teach the new *chain down to dixie* before I teach *dixie style*. I use key words in both *dixies*, such as "Men shake hands," to complete the call. It is amazing how many problems I can remove before they appear in this way. I've started using the word *team-mate* as an aid, and it works.

Going back to the start of this article, not all areas of the country lend themselves to strict interpretation of MS or Plus. I am only being realistic to admit this, and callers must use more judgment than ever.





# MID-AMERICA SQUARE DANCE JAMBOREE INC.

3rd Annual  
September 29, 30, 1989  
Ky. Fair & Exposition Center - Louisville, Ky.



Buddy Allison  
Ga.



Paul Marcum  
Tn.



Darryl McMillan  
Fl.



Bob Newman  
Ky. & Tx.



Tony Oxendine  
S.C.



Bob Baier  
Tx.

\*MAINSTREAM  
PLUS  
ADVANCE  
\*CHALLENGE

ROUNDS  
WORKSHOPS  
Sat.-10-12  
EXHIBITORS

TRAIL END DANCE  
Thurs.-9-11 p.m.  
Local Callers



Jerry Story  
Ia. & Tx.



Randy Dougherty  
Mn.

### DANCING SCHEDULE:

Friday - 1:00 P.M. - 4:00 P.M.  
(Casual Attire Optional)  
Friday - 8:00 P.M. - 11:00 P.M.  
Saturday - 10:00 A.M. - 4:00 P.M.  
7:30 P.M. - 11:00 P.M.  
SQUARE DANCE ATTIRE PLEASE



Elmer Sheffield  
Fl.



Kip Garvey  
Ca.

PRICE PER PERSON - \$17.50  
COMPLETE DANCE PACKAGE

AFTER AUGUST 15, 1989 PER PERSON - \$20.00  
(Deadline for Cancellation Refunds . . . August 15, 1989)  
(\$1.00 charge per person for each cancellation)  
EMERGENCY PHONE NO. AT EVENT ONLY - (502) 366-9592



Keith Rippeto  
W. Va.



Larry Letson  
In. & Tx.

### LOGGING INFORMATION

Please Request Mid-America Reservations  
Headquarters Motel:

EXECUTIVE INN - (502) 367-6161  
Room Rates - 1-4 People - \$57.00

EXECUTIVE WEST - (502) 367-2251  
Room Rates - 1-4 People - \$57.00

Mid-America Square Dance Jamboree, Inc.  
P.O. Box 421  
Fairdale, Ky. 40118  
(502) 368-1006



Johnny Preston  
Ca.



Phil & Becky Guenther  
Ky.



Grant & Barbara Pinkston  
Tn.

Future Date - September 21, 22, 1990

1989		RETURN WITH CHECK FOR RIBBONS		1989		PLEASE CHECK PREFERENCE	
NAME	_____	Last	_____	First	_____	Mainstream	<input type="checkbox"/>
ADDRESS	_____					Plus	<input type="checkbox"/>
CITY/STATE/ZIP	_____					Advance	<input type="checkbox"/>
TELEPHONE (Area Code)	_____					Challenge	<input type="checkbox"/>
RIBBONS WILL BE HELD AT DOOR FOR REGISTRATIONS RECEIVED AFTER SEPT. 10, 1989							
MAKE CHECK PAYABLE TO Mid-America Square Dance Jamboree, Inc. P.O. Box 421 • Fairdale, Ky. 40118							
						Rounds	<input type="checkbox"/>



# Linear Cycle Round the Globe



Central Valley Squares in Southington, Connecticut, had Don Jochum from Pensacola, Florida, as a guest caller in October 1987. One thing led to another, and the club's travel agent (Jennie) worked with Don and Hazel Jochum to make a cruise a reality. In January four squares sailed on Carnival's M.S. *Celebration* to the eastern Caribbean.  
*Jennie and Tom Lee*

## Newest Square Dance MAIL ORDER CATALOG 'P' from Shirley's

24  
 PAGES

FEATURING PATTERNS, APPAREL, AND SPECIALS.  
 SALE PAGE

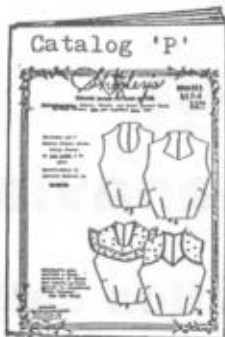

Featured  
 on the  
 cover...

Our newest Pattern Piece,  
**Bodices 5, 6, 7 & 8**  
 all styles and sizes 6-20,  
 included in one package,  
 AND  
 instructions to convert  
 Bodice patterns to Blouse patterns  
 \$3.95 + \$1.50 postage

**PATTERNS:** from Authentic, F. Burrus, C & C, Kwik-Sew, Kentucky Ruffles, and our own interchangeable pieces.

**APPAREL:** Skirts, blouses, shirts, ties, petticoats, Pettipants, small pocketbooks, Butterfly and Stretch belts and more.

**SPECIALS:** Jewelry specials, shirt and skirt specials, and Beginner Dancer Specials.

To Order Cat. P, send \$1.00 refunded on 1st \$10.00 order.

### SHIRLEY'S S/D SHOPPE

Route 9-D Box 423 Dept. #B  
 Hughsonville, NY 12537  
 Telephone (914)297-8504



#### FREE

- To introduce our catalog to your beginner class members, we will send as many FREE
- copies as your club requests if you include 10¢
- per copy to help defray postage costs.



# **World Square Dance Convention 1989**

## **Sweden**

**“Enjoy Scandanavia”**

**For more information call:  
National: 1-800-545-8687  
Illinois: 1-312-771-3384**



# **World Square Dance Convention 1990 Austria**

---

## **Passion Play Year**

---

**For information call:  
National: 1-800-545-8687  
Illinois: 1-312-771-3384**



by Bob Howell

# easy level

*I delight in hearing how people in areas that are quite far apart treat a similar piece of music and develop choreography that adapts to the music. Recently two individuals submitted routines that use the same music, but apply to a totally different age group. The first one comes from Steve Minken of Sebastopol, California, and he says it was written for a bilingual kindergarten class, but older children and the young at heart have been enjoying it, too.*

## THE CALIFORNIA RAISIN DANCE

FORMATION: Circle, all facing center.

MUSIC: *I Heard It Through The Grapevine*—ESP 153

ROUTINE: For all walking steps, hands should be held at shoulder height, both forefingers pointing up, raising and lowering alternate hands as one steps. For all turning steps, hands should be held in a loose fist at chest height and rotated around each other as though both hands were winding string into a ball.

All walk toward center in 4, all turn 1/2 around to face out.

All walk out in four. All turn 1/4 left in 4.

All walk (single file promenade) in 4. All turn 1/2 around in 4.

All walk (wrong-way promenade) in 4. All turn to face center in 4.

Boys walk to center in 4. Boys turn 1/2 around.

Boys walk back out in 4. Boys turn around to face center in 4.

Girls walk to center in 4. Girls turn around 1/2 in 4.

Girls walk back out in 4. Girls turn around to face center in 4.

Dance repeats seven times with lots of chances for the dancers to develop and embellish their hand movements and strutting techniques.

*The second use of the tune was shared by Lou Hyll of Dayton, Ohio, who learned it from his daughter, Leslie. It is a solo dance entitled...*

## I HEARD IT ON THE GRAPEVINE

FORMATION: Scattered, all facing leader.

INTRO: Sway back and forth snapping fingers

AT VOICE:

Push right hand down 4 times, push left hand down 4 times

Push right hand up 4 times, push left hand up 4 times

Right hand thumber 4 times, left hand thumber 4 times

Bend over and twirl (twiddle) hands (2 counts)

Stand up with arms over head (2 counts)

Repeat above figure, twirl hands and arms up

Standing with arms up, put right hand down to left hip (2 counts)

Put left hand on right hip (2 counts)

Put right hand on right hip (2 counts)

Put left hand on left hip (2 counts)

Bounce up and down 4 times, begin again by swaying several times\*

\*I use it by bouncing up and down 3 times and on the fourth bounce I bounce-turn 1/4 right to begin the dance facing a new direction.



*David and Charlene Frankenfield of Pinellas Park, Florida, danced with Jerry Helt and me at our Traditional Dance Week at Copecrest last April. During the week, Jerry did one of his humorous spoofs of a "barnyard shuffle" routine and the Frankenfields returned home to compose a little nonsense dance which they called...*

## JERRY'S BARNYARD QUADRILLE

MUSIC: *Turkey in the Straw*

Intro — — — —, — — Set twice  
1-8 — — — —, — — Right and left thru 33-40 Left foot look at sole, with corner clap hands  
9-16 — — — —, — — Right foot shuffle 41-48 — — — —, — — Swing corner  
17-24 — — — —, — — Left foot shuffle 49-56 — — — —, — — Promenade  
25-32 — — — —, Right foot look at sole 57-64 — — — —, — — Set twice

Shuffle: Point toe for two counts, draw back on outside edge of foot for two counts. Point same toe for two beats, draw back on inside of foot for two beats.

Clap hands: Twice on knees, twice together, right hand with partner, once together, left hand with partner, once together.

Story line: Set twice is hesitation crossing the barnyard. Half promenade is crossing the barnyard. After checking shoes, everything is O.K. So clap hands, swing, promenade.

*To continue with our April Foolishness, John Hucko of Oviedo, Florida, sent me a routine several years ago that involves a "who turns who" figure. It works well with a standard 64-count singing call:*

Head two gents and corner girl, up to the middle and back

Box the gnat, right and left thru the other way back

Join hands and circle left, two boys, two girls together

Four girls (boys) square thru four hands, right and left thru with outside two (who turns who)

Dive thru, square thru three hands, left allemande...

*Bill and Alyce Johnson of San Clemente, California, came through the Cleveland area last November and danced with the Kings and Queens Contra Club. He prompted the following contra which he had written. It was a real crowd pleaser. Bill calls it the...*

## FLUTTER PASS THROUGH

MUSIC: *She Dreamed*, Windsor 7157A (I use *Old Joe Who*, Big Mac 1005B)

FORMATION: Alternate duple

Intro — — — —, Balance with your corner 33-40 — — Plus a quarter, — — pass thru  
1-8 — — — —, Swing that girl 41-48 — — Star thru, — — Circle left\*  
9-16 — — — —, Face across, ladies chain 49-56 — — — —, — — Star left  
17-24 — — — —, — — Chain back 57-64 — — — —, Balance with your corner  
25-32 — — — —, Ladies flutter wheel \*Cross over every second change.

**FRONT LINE COVERAGE**— Artist Ted Staley of Cascade, Maryland, has captured in the cover illustration what we'd all like to see more of—old and young alike enjoying a square dance together, even if the young people seem to be quite preoccupied with each other! As the season of festivals and specials approaches (as well as the season of young love), wonder what *you* are doing to close the generation gap and really *involve* our young people—square dancing's future.



Sam Atkinson



**REBEL RECORDS**  
321 Stallo St.  
Monte Vista, CO 81144



Dale Miller



Larry Buhler

★★★ NEW RELEASE ★★★  
REB-112 ROCK-A-BILLY REBEL by Dale  
★★★ CURRENT RELEASE ★★★  
REB-111 REBEL EXPRESS Patter  
★★★ COMING SOON ★★★  
REB-113 DELTA DIRT by Larry



Jeff Nelson



# English Mountain

## AMERICA'S NEWEST AND FINEST SQUARE DANCE RETREAT

### 2 DAY WEEKEND SCHEDULE 1989

<b>APRIL 28-30 (**)</b> Cherokee Recording Staff Ken Bowen (CA) Gary Shoemaker (TN) Joey Hays (TX) Scott Smith (AZ) Bert, Max (CO) Ray/Bea Dobby (WV) [R]	<b>MAY 5-7</b> "SPECIAL WEEKEND" George Lawless (AL) Gary Shoemaker (TN) Some Love (NC) [R]	<b>MAY 12-14</b> Buddy Allison (GA) Bill McVey (GA)	<b>MAY 19-21</b> Ron Dax, (IN) Susan Dick, (IN) [R]	<b>MAY 26-28</b> Jay Price (VA) Ruth Marks (VA) [R]	<b>JUNE 2-4</b> Cindy Johnson (OH) Cecil Sims (WV) Bill/Sandy Bush (WV) [R]	<b>JUNE 9-11</b> Jerry Boatman (NC) Dana Coe (NC) Bill/Edna Anderson (NC) [R]
<b>JUNE 16-18</b> Bill Buschamer (OH) Ron Eshelhart (IN) Joy Eshelhart (IN) [R]	<b>JUNE 23-25</b> Ray Dobby (TN) Roy Hays (GA) Curtis Earl Jordan (TN) [R]	<b>JUNE 30-JULY 2</b> Chuck Meyers (AL) Sue Duns (OH) Dorothy Roma (OH) [R]	<b>JULY 7-9 (**)</b> Red Boat Boys Special "Live Music" Squares & Rounds	<b>JULY 14-16</b> Harley McCollum (WV) Gloria Shell (VA) G. W. White (VA) [C/O] Fun Lovin' (SD) Squares Only	<b>JULY 21-23</b> Good "O. B. Best" Sue Duns (OH) Max King (OH) Kermit Zimmerman (OH)	<b>JULY 28-30</b> Mac Little (AL) Jay Hosen (AL) Wanda Ann McCreary (AL) [R]
<b>AUG. 4-6</b> Happy Lacey (NC) Mac, Ester (AL) Mavis Patterson (KY)	<b>AUG. 11-13</b> Pete Kinsinger (IN) Kevin Robinson (KY) Pete V. Anderson/Robby Bolton (OH) [R]	<b>AUG. 18-20</b> Kris Bunn (IL) Burt/Mary Tracy (IN) [R]	<b>AUG. 25-27</b> Gene Record (KY)	<b>SEPT. 1-3</b> The Red Boat Boys (TN)	<b>SEPT. 8-10</b> Sue Love (SC) Meredith Fontana (NC) [R]	<b>SEPT. 15-17</b> Eddie Powell (OH)
<b>SEPT. 22-24</b> Wendell Lowman (GA)	<b>SEPT. 29-OCT. 1</b> Colin Dyer (AL) Dawn Weiss (GA) Joni/Elly Gentry (MS) [R]	<b>OCT. 6-8</b> Bill Stroh (OH)	<b>OCT. 13-15</b> Mae Hoot (TN) Wendy McDonald (TN) Bill Harman (MS) Dix Smith (TN) [R]	<b>OCT. 20-22</b> Harold Kelley (GA) Joye Simola (GA) Hal/Sue Robbins (GA) [R]	<b>OCT. 27-29</b> Don Williams (TN) Phyllis Ellington/Dave Hines (NC) [R]	<b>NOV. 3-5</b> Pats Marcus (TN) Ruth/Mary Saur-wort (KY) [R]

ALL WEEKS PLUS UNLESS INDICATED OTHERWISE

(\*\*) DENOTES SPECIAL DATES, PLEASE CALL FOR PRICE INFORMATION.

LEISURE SUITES AND CONDOS AVAILABLE. ALSO CAMPGROUND (RV SITES) WITH FULL HOOKUPS

PLUS THESE FACILITIES FOR YOUR USE: HEATED POOL, LIGHTED TENNIS COURTS, MINI-GOLF, HORSESHOES, GIFT SHOP, SHUFFLEBOARD AND 2 WHIRLPOOL HOT TUBS.

FOR MORE INFORMATION CONTACT ENGLISH MOUNTAIN SQUARE DANCE RETREAT, Rt. 6, Box 212, SEVIERVILLE, TN 37862; OR CALL 615-453-0171

# English Mountain

## AMERICA'S NEWEST AND FINEST SQUARE DANCE RETREAT

### 5 DAY SCHEDULE 1989

<b>APRIL 23-28 (**)</b> Kin Bowen (CA) Tom Osborne (SC) Joey Stroy (TX) Ray/Bea Dobby (WV) [R]	<b>APRIL 30-MAY 5</b> Walt Babin (FL) Chuck Dunsen (FL) Bob/Verna Burnier (FL) [R]	<b>MAY 7-12</b> "Rouba Wires" Tom/Elly Keweenaw (KY) Roy/Elly Yankinator (KY) Ray/John Collins (IN) "Calling Squares" (**) Walt Dobby (TX) Gary Shoemaker (TN)	<b>MAY 14-19 (**)</b> "Rouba Wires" Har/Betty Eastday (MO) Power IV, V, VI (Dancers & Teachers)	<b>MAY 21-26</b> Walt Mosher (TX) Doc Gray (FL) Jesse/Gloria Cozler (FL) [R]	<b>MAY 28-JUNE 2 +</b> "Squares With" Tom Mosher (FL) Mavis Clasing (OH)	<b>JUNE 4-9 +</b> Aron Pritts (LA) Bobby Newman (KY) Mavis Turner (KY) Nancy/Walt Carter (KY) [R]
<b>JUNE 11-16 +</b> Sue Hunt (MO) Pat Dances (AR) Joey/Dor/Dokey (MS) [R]	<b>JUNE 18-23</b> Kin Bowen (CA) Dina Cozler (TX) Mavis/Pat Price (TX) [R]	<b>JUNE 25-30</b> Les Greenwood (CA) Lorne Loober (CA) Rick & Althea (CA) Squares (CA) [R]	<b>JULY 2-7</b> Margaret F. Price (TX) Daw/Edna Prosser (PA) [R]	<b>JULY 9-14</b> Joey Stroy (TX) Larry Linton (TX) Joni/Elly Prosser (IL) [R]	<b>JULY 16-21</b> Frank Gentry (OH) Scotty Sherman (OH) Cheryl/Gary/Elly Hays (OH) [R]	<b>JULY 23-28</b> Les Mann (OH) Dale Toner (MO) Bob/Maria Cozler (MS) [R]
<b>JULY 30-AUG. 4</b> Walt Dobby (TX) Tom Mosher (VA) Bill/Betty Lacey (AZ) [R] "Calling Squares" (**) Jack Lacey (FL) Earl Johnston (CT)	<b>AUG. 6-11</b> Guss Rose (IN) Art Towner (OH) Dick/Gae, Blaine (OH) [R]	<b>AUG. 13-18</b> Jay Price (MI) Dawn Robinson (FL) Curtis/Sue Weiss (MS) [R]	<b>AUG. 20-25</b> Tom Miller (PA) LARRY PRICH (FL) LARRY PRICH (FL) [R]	<b>AUG. 27-SEPT. 1</b> JOY CARLTON (MO) Pete Dyer (MO) R.J. Hoot (FL) Suzanne/Wayne Gentry (FL) [R]	<b>SEPT. 3-8</b> Ron Sherman (FL) Bud/Doris Miller (OH) [R]	<b>SEPT. 10-15</b> Harold Robbins (MO) Liner Cozler (MO) Gene/Gae McClurkin (MO) [R]
<b>SEPT. 17-22</b> Vera, Thelma (IN) John Pat. Brennan (AL) Pat/Larry Wolf (IN) [R]	<b>SEPT. 24-29</b> LARRY LINTON (TX) Lita Gentry (LA) Mavis/C. P. Hays (MS) [R]	<b>OCT. 1-6</b> Kin Bowen (CA) Gary Shoemaker (TN) Roy/Dor/Joey Lacey (AL) [R]	<b>OCT. 8-13</b> Bill Harman (MO) Mae Hoot (TN) Wendy McDonald (TN) Tom/Elly Keweenaw (KY) [R]	<b>OCT. 15-20</b> Ramon Marshall (OH) Joni/Elly Cozler Lloyd/Ellen Lowman (PA) [R]	<b>OCT. 22-27</b> Tom Osborne (SC) Joey Stroy (TX) Jay/Phyllis Acock (VA) [R]	<b>OCT. 29-NOV. 3</b> Sue Gentry (LA) Bill Yoder (MO) Bud/Maria Dobby (LA) [R]

ALL WEEKS PLUS UNLESS INDICATED OTHERWISE

(\*\*) DENOTES SPECIAL DATES, PLEASE CALL FOR PRICE INFORMATION.

DIRECTOR, GARY SHOEMAKE, WILL CALL EACH 5 DAY PROGRAM WITH THE SCHEDULED STAFF EXCEPT FOR WEEKS INDICATED WITH A +.

LEISURE SUITES AND CONDOS AVAILABLE. ALSO CAMPGROUND (RV SITES) WITH FULL HOOKUPS

PLUS THESE FACILITIES FOR YOUR USE: HEATED POOL, LIGHTED TENNIS COURTS, MINI-GOLF, HORSESHOES, GIFT SHOP, SHUFFLEBOARD AND 2 WHIRLPOOL HOT TUBS.

FOR MORE INFORMATION CONTACT ENGLISH MOUNTAIN SQUARE DANCE RETREAT, Rt. 6, Box 212, SEVIERVILLE, TN 37862; OR CALL 615-453-0171

# English Mountain

AMERICA'S NEWEST AND FINEST SQUARE DANCE RETREAT

## JULY 2-7, 1989

MARSHAL FLIPPO  
TEXAS

GARY SHOEMAKE  
TENNESSEE

DAN & LINDA PROSSER  
PENNSYLVANIA

### 5 DAY RATE SCHEDULE

**LEISURE SUITE OR CONDO** (ACCOMMODATIONS DEPEND ON AVAILABILITY) PRICES BASED ON DOUBLE OCCUPANCY.

5 DAY PACKAGE: \$275.00 PER PERSON / \$550.00 PER COUPLE, 3RD OR 4TH PERSON SHARING SAME ACCOMMODATIONS; \$245.00 EACH (LIMIT 2)

5 DAY PACKAGE IS FROM SUNDAY DINNER THRU FRIDAY BREAKFAST AND INCLUDES THE FOLLOWING: LEISURE SUITE OR CONDO - ALL MEALS - ALL DANCE SESSIONS AND ADMISSION TO THE SMOKEY MTN. JUBILEE SHOW. CHECK IN 3:00 P.M. SUNDAY, CHECK OUT 10:00 A.M. FRIDAY.

SINGLE OCCUPANCY ON ABOVE IS \$462.50 \* CHILDREN'S PRICES UPON REQUEST

**CAMPGROUND (RV SITES)** (FULL HOOK UPS AVAILABLE) - PRICE INCLUDES ALL MEALS

5 DAY PACKAGE: \$210.00 PER PERSON / \$420.00 PER COUPLE, 3RD OR 4TH PERSON SHARING SAME CAMPER \$180.00 EACH (INCLUDES SAME AS ABOVE.)

PLUS THESE FACILITIES FOR YOUR USE: HEATED POOL, LIGHTED TENNIS COURTS, MINI-GOLF, HORSESHOES, GIFT SHOP, SHUFFLEBOARD AND 2 WHIRLPOOL HOT TUBS.

ENGLISH MOUNTAIN SQUARE DANCE RETREAT  
RT. 6, BOX 212 \* SEVIERVILLE, TN 37862  
FOR MORE INFORMATION CALL: 615-453-0171

(NO CHARGE CARDS ACCEPTED. ALL PRICES SUBJECT TO TENNESSEE SALES TAX. \$50.00 DEPOSIT MUST ACCOMPANY ALL REGISTRATION FORMS AND IS REFUNDABLE UP TO 30 DAYS PRIOR TO SCHEDULED ARRIVAL, LESS A \$10.00 PROCESSING FEE.)

NAME (HIS) \_\_\_\_\_ (HERS) \_\_\_\_\_ LAST \_\_\_\_\_  
ADDRESS \_\_\_\_\_ CITY \_\_\_\_\_ STATE \_\_\_\_\_ ZIP \_\_\_\_\_  
PHONE ( ) \_\_\_\_\_ DATE OF ARRIVAL \_\_\_\_\_ PREVIOUS # OF TIMES ATTENDED \_\_\_\_\_  
WEEK YOU WISH TO ATTEND \_\_\_\_\_ CALLER'S NAME \_\_\_\_\_  
LEISURE SUITE \_\_\_\_\_ CONDO \_\_\_\_\_ CAMPGROUND \_\_\_\_\_



by  
Ed Foote

## POINT TO POINT DIAMONDS

### An Important Formation for Advanced Dancers.

Point-to-point diamonds are twin diamonds in which the points are side-by-side through the center of the set (normally the centers of the diamonds are side-by-side through the center of the set). An easy way to set up point-to-point diamonds is to have parallel two-faced lines do a *couples hinge* and then have the centers of each line *hinge*.

Although point-to-point diamonds are permissible at the Plus program, most callers avoid them at this program. This is fine, but unless dancers in Advanced class are taught point-to-point diamonds, these dancers will always believe that twin diamonds must have the centers be a wave down the middle.

### A Typical Occurrence at Advanced.

The caller will put the floor into point-to-point diamonds, but in some squares the dancers who are not well trained will change to normal twin diamonds, i.e., the dancers in the center of the set will take hands and the true centers will drop hands, thereby making themselves the points. These sets have now reversed the location of the centers and points from what the caller wants.

There is no problem as long as the caller calls *diamond circulate*. But as soon as the caller calls *flip* or *cut the diamond*, which ends in a tidal setup, the squares who have changed to normal diamonds are in trouble. The *flip* or *cut* will put these squares into parallel waves or lines. Thus, the floor is supposed to be in a tidal setup, but the incorrect squares are in a parallel set-up. The next call will now result in an instant breakdown of the incorrect

squares with no chance of recovery.

### Why Are Point-to-Point Diamonds Used?

Because they provide a simple but effective way to instill mental discipline into Advanced dancers. At Mainstream and Plus, most dancers merely coast along doing little or no thinking. This is fine for these programs. But at Advanced, the dancers are expected to exert some degree of mental application. Point-to-point diamonds teach the dancers to believe the caller, to accept whatever situation he establishes. This mental process is vital for training dancers to accept the directional calling of creative choreography which is used at Advanced. The dancers must have the mental discipline to do exactly what the caller says and not make adjustments on their own.

### Things To Remember:

1. The caller is under no obligation to use the phrase *point to point diamonds*. He can simply set up this formation and continue. The dancers are expected to recognize that they are in this situation. Some callers may use the phrase if the floor is weak or if they are unsure of the ability of the floor.
2. Once a diamond is established, the centers always have hands joined and the points never have hands joined. The dancers merely have to remember where the positions are for the centers and points. If dancers would always follow this simple but vital rule, they would not have to be concerned whether or not the diamonds were normal or point-to-point, because they would never break down.

Because point-to-point diamonds is not specifically listed as a formation on the Advanced List, some callers ignore the formation. Obviously, this causes problems when their dancers dance to another caller. If your caller is not exposing you to point-to-point diamonds at Advanced, request that he do so.

Advanced dancers should be alert to the location of centers and points in a diamond, and not assume the centers will be in a wave through the center.



# CALLER LINE-UP

These Callers Are Available To Call For Clubs and Festivals...Call Them!



Bill Barr (203-934-2653)  
421 Campbell Ave. Box 352  
West Haven CT 06516  
**Have a Train Nite  
With "Railroad Bill"  
Traveling Weekends**



Walt Cole (801-392-9078)  
944 Chatelain Rd.  
Ogden UT 84403  
**The basis of calling is timing  
The basis of timing is music**

Stan Burdick  
216 Williams St.  
Huron OH 44839  
**The Meandering Man**



Don Coy (502-491-8878)  
118 Bonnie Ln.  
Louisville KY 40218  
**Calling Wknds & Festivals  
You Ring, I Sing!**



Jim "Who" Cholmondeley  
12610 Lusher Road  
Florissant MO 63033  
(314)741-7799 or 653-1441  
**The Caller Who Cares**



Ralph Kornegay  
138 Mohican Tr. (919-392-1789)  
Wilmington NC 28403  
**The "Dr. of Squares"  
Weekends & Holidays**

**YOUR AD COULD FILL THIS SPACE.  
ASK FOR DETAILS!**

Paul Kubler  
Rt 3 Box 680  
Reidsville NC 27320  
919-342-4759  
**Teddy Bear—Will Travel**



## THERE'S ROOM FOR A VERY FEW TO SIGN UP FOR THE Square Dance Ambassadors' TOUR TO IRELAND AND SCOTLAND May 30 - June 9, 1989

*Stan & Cathie Burdick, Tour Hosts and Leaders*

A Landmark Festival Program  
Sponsored by  
**AMERICAN SQUAREDANCE**

via  
**Aer Lingus**



Write for the colorful brochure describing this fabulous Scotland/Ireland Tour through the lands of pageantry, legend, kings, saints, poets, kilts, bagpipes and tartans.

Stan and Cathie Burdick, ASD editors, will be your personal escorts. Special low price includes air, meals, hotels—the works. And one busload is our limit. Write now, *begorra*. If you miss it, you'll be green with envy.



**ASD TOURS P.O. BOX 488 HURON, OHIO 44839**

# LINE-LIGHT



Louis and Kathleen Riddell of Chatham, Illinois celebrated their fiftieth wedding anniversary on October 23, 1988 with an open house and square dance at the Chatham Community Center. About 200 guests were present and enjoyed the calling of Bud Welch, Don Mcconnell, Bob Whiteman and Wayne Ackerman.

The Riddell's have been active in the square dance movement for the past twenty years. They played a key role in the founding of the Chummy Chainers Square Dance Club in Chatham. They are charter members and have served as officers for eight years. They also support the two Springfield clubs, The Swinging squares and the Springfield Squares, and have held offices in these two clubs. At present they are also active campers and are serving as treasurers for the Lincolnland Trailblazers.

Soon after entering the square dance activity, Kathleen opened *Kathleen's Square Dance Shop*. This activity has been a rewarding experience in many different ways. For the past several years the Riddells have worked four major festivals and conventions each year.

Kathleen has several picture albums and other memorabilia covering their twenty years in square dancing. Louis and Kathleen still find enjoyment and satisfaction in being angels with both the Chatham and Springfield clubs each year.

Kathleen and Louis are both diabetic but find the activity is a help in many ways, and they encourage others to get involved.



**TOM MANNING**



## SOLID GOLD SQUARE DANCE RECORDS

T-N-J PRODUCTIONS  
P.O. Box 175  
MIDDLETOWN, IA 52638-0175  
(319) 752-4205



**NICK HARTLEY  
JIM FORD**

AVAILABLE THROUGH  
TWELGRENN, AZTEC,  
MERRBACH & SUNDANCE

Having trouble buying?  
Please call T-N-J  
for a local dealer.

### NEW RELEASES

- SG301—GET ME BACK TO DIXIE by Nick
- COMING SOON
- SG101—SKAGGS'S HOSS — Hoedown
- SG201—I'M MADE FOR DANCING by Tom
- SC401—TWO CAR GARAGE by Jim
- SG501—WILL IT BE LOVE BY MORNING







Jerry Story



Tony Oxendine



Larry Letson



records

### BRAND NEW RELEASES

- RYL 402 KAYLA RAE /JAKE Patter
- RYL 305 DO RUN RUN by Jerry and Tony
- RYL 701 BEAUTIFUL DAY by Kip Garvey
- RYL 502 A DAY LATE & A DOLLAR SHORT by Larry Letson

### NEW RELEASES

- RYL 106 I'LL HAVE TO SAY I LOVE YOU IN A SONG by Jerry by Tony
- RYL 206 I BELIEVE IN MUSIC by Jerry/Tony/Paul Marcum
- RYL 303 MORNING SKY by Jerry/Larry
- RYL 304 WHY MUST WE EVER SAY GOODBYE by Jerry/Tony/Larry
- RYL 601 TENNESSEE RIVER

### BEST SELLERS

- RYL 105 LOUISIANA FAIS DO-DO by Jerry
- RYL 205 YOU DON'T HAVE TO BE ALONE, Tony
- RYL 206 I BELIEVE IN MUSIC by Tony
- RYL 501 ROCK AND ROLL LULLABYE by Larry
- RYL 101 SOMEBODY LIKE ME by Jerry
- RYL 102 BLAME IT ON MEXICO by Jerry
- RYL 103 YOU'RE STILL THE ONE by Jerry
- RYL 104 FANCY FREE by Jerry
- RYL 201 THE PRIDE IS BACK by Tony
- RYL 202 EVERYBODY LOVES A LOVER by Tony
- RYL 203 TWO OUT OF THREE AIN'T BAD by Tony
- RYL 204 AROUND THE WORLD WITH BILL BAILEY by Tony
- RYL 301 BEAUTIFUL BROWN EYES by Jerry/Tony
- RYL 302 DREAMING by Jerry/Tony
- RYL 401 JOSH/RICKY, Patter

JOIN THE ROYAL RECORD STAFF FOR THE WEEKEND  
APRIL 28-29 MUSIC CITY FESTIVAL, Nashville, Tennessee

ROYAL RECORDS INC., Rt.1 Box 33, Fairfield IA 52556 515-472-3795



EXPERIMENTAL BASIC

# PULSE POLL



40 Callers Contribute Monthly

**CALLERLAB QUARTERLY SELECTIONS**

**MAINSTREAM**

Hang a right (left)  
Cloverflo

**PLUS QS**

Zip to a diamond

**ADVANCED QS**

Counteract  
Shadow the column  
Lock the top

**MAINSTREAM & PLUS LIST**

1988 Update  
Order IN-form X-4 from  
ASD, 50¢ one copy

**QS DEFINITIONS & DIAGRAMS**

Order IN-form J-6 from  
ASD 50¢ one copy

**PLUS PROGRAM**

All eight spin the top  
Anything and roll  
Anything and spread  
Chase right  
Coordinate  
Crossfire  
Diamond circulate  
Dixie grand  
Explode family  
    a. waves  
    b. and anything  
Extend  
Flip the diamond  
Follow your neighbor  
Grand swing thru  
Linear cycle  
Load the boat  
Peel the top  
Ping pong circulate  
Relay the deucey  
Remake the thar  
Single circle to a wave

Spin chain and exchange the gears  
Spin chain the gears  
Teacup chain  
¾ tag the line  
Track two  
Trade the wave  
Triple scoot

**ASD PULSE POLL**

ASD

**EXPERIMENTALS**

Not a Callerlab program

Caution: Not recommended for dancers prior to Plus program activity.

**EXPERIMENTALS**

1. Slam the door
2. Zip to a diamond
3. Relay the deucey with 2 stars
4. Chain down to Dixie

(Priority order)

## REEVES RECORDS INC. EDDIE'S & BOBBIE'S RECORDS MAIL ORDERS PROMPTLY FILLED

SQUARE, ROUND AND  
CLOGGING RECORDS  
DIPLOMAS  
RECORD CASES

BOOKS & MANUALS  
PLASTIC  
RECORD  
JACKETS

TOA WIRELESS  
PHONOGRAPH NEEDLES  
MIKES & ACCESSORIES

We also have records that are hard to find  
and have been listed as not available.

EDDIE—BOBBIE—ROBBIE  
REEVES

P.O. Box 17668  
DALLAS, TEXAS 75217-0668

1835 So. Buckner  
214/398-7508

# Round Dance



## PULSE POLL



### PHASE I & II

1. King of the Road
2. Fiddlestepper Polka/  
Sam's Song/  
Salty Two Step
3. Walkin' and Whistling
4. A Time For Love

### PHASE III

1. Die Lorelei
2. A Beautiful Time/  
Deja Vu
3. Axel F
4. I'll Be The One

### PHASE IV

1. Rainbow Connection IV
2. White Sport Coat

### PHASE V & VI

1. Sunflower
2. Tiy're The Top Cha
3. Allegheny Moon
4. Orient Express Foxtrot

### MOST POPULAR DANCES voted and enjoyed by 224 National Carousel Clubs (Adv. and High-Int. Levels)

1. You're The Top Cha (Childers)
2. Allegheny Moon (Barton-Christmas)
3. Chardonay (Easterday)
4. Foxtrot Tonight (Goss)
5. Coppelia (Palmquist)
6. Currita De La Cruz (Easterday)
7. Rumba Calienta (Shibata)
8. El Toro Paso (Palmquist)
9. Spider of the Night (Goss)
10. Sunny Cha (Easterday)
11. Ramona (Krol)
12. You Alone (Palmquist)
13. That's You (Smarrelli)
14. Champagne Quickstep (Rother)
15. Mint Julep (Rother)
16. Amore Bachiami '88 (Palmquist)

### 1988-89 ROUNDALAB CLASSIC LIST

#### PHASES I & II

- Could I Have This Dance  
A Taste of the Wind  
Very Smooth  
Hush  
Buffy  
New York, New York  
Houston  
Baby O'Mine  
Neapolitan Waltz  
Good Ol' Girls  
Jacayn's Waltz  
All Night/KonTiki  
Piano Roll Waltz  
Pearly Shells

#### PHASE III

- Alice Blue Gown  
Patricia  
Desert Song  
Crazy Eyes  
Maria Rumba  
Butterfly  
Apres L'Entrient  
Lisbon Antiqua  
That Happy Feeling  
Third Man Theme

- In the Arms of Love  
Hallelujah  
Beautiful River  
Sheik of Araby  
Games Lovers Play/  
Three A.M.

#### PHASE IV

- Pop Goes the Movies  
I Want A Quickstep  
Gazpacho Cha  
Dance  
Til Tomorrow  
Lazy Sugarfoot  
Rainbow Foxtrot  
Biloxi Lady  
Marilyn, Marilyn  
Hooked On Swing

#### PHASES V & VI

- Maria Elena  
Adios  
Tampa Jive  
Para Esto  
Send Her Roses  
Lovely Lady  
Hawaiian Wedding Song  
La Pura  
Cavatina  
Caress/Sugarfoot  
Stomp/Till

Callerlab RQD: ONE MORE TIME

... Funship Jubilee Caribbean Cruise Nov. 5, 1989 ...

## HOW TO FALL IN LOVE ALL OVER AGAIN

Cut out this ad, hand it to the person you love and say  
"Let's go". "Let's go dancing under the stars in the Caribbean ..."

on

## CARNIVAL'S FUNSHIP JUBILEE

### November 5, 1989

A week of pampering ... a week of romance ... a week of square  
dancing ... so grab your dancing shoes and call ...



"We dance the world over"

### 1-800-666-3359

In St. Louis Call  
UNITED SQUARES of AMERICA  
% Travel Agents International  
(314) 391-7540



# Creative Choreography

by Ed Fraidenburg

CHOREOGRAPHY

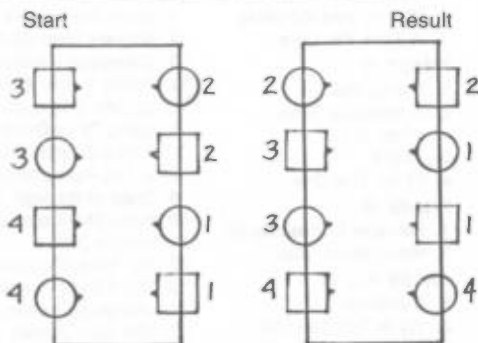

Quarterly  
Selection

## GRAND SWING THRU

A "no change" call with possibilities.

From facing lines, draw an imaginary line through each line of dancers and connect the ends. *Grand swing thru* simply moves everyone one position counterclockwise along this line, and there is no change in rotation or affiliation; therefore, any get-out that will work from the starting formation will also work following a *grand swing thru*. Any number of *grand swing thrus* may be called.

### EXAMPLE:

Heads lead right and circle to a line  
Touch to a wave, single hinge, circulate  
(Any number of times), boys run\*  
Left allemande...

\*Or girls run, right and left grand...

Or, from the line you started with:  
Grand swing thru (any number of times)  
Single hinge, circulate (any number of times)  
Boys run\*, left allemande...

Or, girls run, right and left grand...

*Grand left swing thru* moves everyone one position clockwise with no change in rotation or affiliation, so the same precept applies. Try this:  
Heads lead right and circle to a line  
Grand left swing thru (any number of times)  
Single hinge, circulate (any number of times)  
Boys run\*, right and left grand...

\*Or girls run, left allemande...

## CLOVERFLO

After a good deal of searching, I find that *cloverflo* was authored by Bill Davis in late '72 or early '73, and was on the Plus 1 list in '77.

From a trade by formation, outfacers cloverleaf and pass thru as infacers pass thru and cloverleaf.

### SAMPLE CHOREO:

Heads square thru four, square thru  $\frac{3}{4}$   
Cloverflo, square thru  $\frac{3}{4}$ , cloverflo  
Left allemande...

Heads square thru four, pass thru, cloverflo  
Pass thru, trade by, left allemande...

Head ladies chain, heads lead right and circle  
To a line, pass thru, wheel and deal  
Square thru  $\frac{3}{4}$ , pass thru, cloverflo  
Left allemande...

*Singing call:* Heads promenade  $\frac{1}{2}$

In the middle and star thru, California swirl  
Square thru  $\frac{3}{4}$ , cloverflow, allemande left  
Do-sa-do back to back, swing, promenade...



Sides rollaway, heads lead right and circle  
Men break to lines, pass thru, wheel & deal  
Square thru  $\frac{3}{4}$ , pass thru, cloverflo  
Swing thru, girls trade, pass the ocean  
Swing thru, right and left grand...

Heads pass thru, go round one to a line  
Pass the ocean, swing thru, centers run  
Wheel and deal, pass thru, cloverflo  
Swing thru, girls trade, square thru four  
Trade by, left allemande...

Heads lead right and circle to a line  
Rollaway, slide thru, cloverflo, swing thru  
Girls circulate, boys run, ferris wheel  
Square thru  $\frac{3}{4}$ , left allemande...

Modules from an eight chain thru formation:

1. Pass thru, cloverflo, pass thru  
cloverflo = zero...
2. Square thru  $\frac{3}{4}$ , cloverflo, square thru  $\frac{3}{4}$   
cloverflo = zero...
3. Pass thru, cloverflo, square thru  $\frac{3}{4}$   
cloverflo = right and left thru...
4. Square thru  $\frac{3}{4}$ , cloverflo, pass thru,  
cloverflo = right and left thru...

## REVIEW



### PASS TO THE CENTER

*Pass to the center* is best when used where *dive thru* is inappropriate (e.g., right-hand waves, left-hand waves, boys together as a couple, girls together as a couple, and arrangements where some are half-sashayed and some are "normal").

Starting formation: eight chain thru, parallel waves.

All pass thru, Dancers now on the outside partner trade. Ends in double pass thru formation.

#### SAMPLE CHOREO:

Heads lead right and circle to a line  
Spin the top, pass to the center, swing thru  
Recycle, zoom and swing thru, step thru  
Left allemande...

Heads half square thru, do-sa-do (ocean wave)

Centers trade, pass to the center  
Square thru  $\frac{3}{4}$ , left swing thru, recycle  
Star thru, wheel and deal, square thru  $\frac{3}{4}$   
Left allemande...

Heads pass thru, go round one to a line  
Pass the ocean, swing thru, pass to the center  
Swing thru, step thru, do-sa-do (wave)  
Boys run, spin the top, same sexes trade  
Right and left grand...

Heads square thru four, sides rollaway  
Swing thru, centers run, wheel and deal  
Box the gnat, pass to the center  
Right and left grand...

PULPOLLEX

### (MAKE A) DANDY LION

From a quarter tag, centers pass thru and star thru with the outside two to form a line.

#### SAMPLE CHOREO:

From Bill Davis, *The New View*  
Heads pass the ocean, make a dandy lion  
Pass thru, wheel and deal, centers star thru  
Pass the ocean, ladies trade  
Ping pong circulate, make a dandy lion  
Pass thru, partner trade and roll  
Right and left grand...

Heads star thru and spread, pass thru  
Wheel and deal, girls swing thru  
Make a dandy lion, boys trade,  $\frac{1}{2}$  circulate  
Bend the line, you're home...

Heads star thru, double pass thru, peel off  
Pass thru, wheel and deal, boys swing thru  
Make a dandy lion, girls trade, ferris wheel  
Centers sweep  $\frac{1}{4}$ , all sweep  $\frac{1}{4}$ , you're home...

Heads star thru and spread, pass thru  
Wheel and deal, zoom, boys swing thru  
Make a dandy lion, couples circulate  
Ladies trade, boys run, right and left grand  
You're home...

Heads star thru, double pass thru, centers in  
Cast off  $\frac{3}{4}$ , pass thru, wheel and deal  
Girls swing thru, make a dandy lion  
Couples circulate, boys trade, bend the line  
Pass thru, wheel and deal, centers sweep  $\frac{1}{4}$   
You're home...



Heads lead right and circle to a line  
 Pass thru, wheel and spread, pass thru  
 Tag the line right, ferris wheel  
 Boys swing thru, ping pong circulate  
 Make a dandy lion, ferris wheel, dixie grand  
 Left allemande...



**HAVE A LITTLE FUN**  
 by Charles Lehmar

From a  $\frac{3}{4}$  tag formation, wave dancers cast  $\frac{3}{4}$  and spread, outfacers peel (right) and roll. Ends in an eight chain thru formation.

NOTE: Some fudging is required to attain the ending formation.

**AUTHOR'S EXAMPLES:**

Heads (sides) square thru four, swing thru  
 Boys run,  $\frac{3}{4}$  tag, have a little fun  
 Pass to the center, square thru  $\frac{3}{4}$   
 Left allemande...

Heads (sides) swing thru, spin the top  
 Extend, trade the wave, left swing thru  
 Girls run, have a little fun, pass thru  
 U-turn back, left allemande...

**HAVE A LOTTA FUN**

From a  $\frac{3}{4}$  tag formation, *have a little fun* and peel the top.



**PLUS QS**

Heads pass thru, go round one to a line  
 Pass thru, wheel and deal, swing thru  
 Scoot and relocate, extend, single hinge  
 Boys trade, boys run, crossfire, circulate  
 Boys run, star thru, pass thru, wheel & deal  
 Dixie grand, left allemande...

Side ladies chain, heads pass thru

Both turn left, gent round two, lady round one  
 To a line, rock the boat, ladies trade  
 Cross the ocean, right and left grand...

Heads lead right and circle to a line  
 Spin the top, boys run, ferris wheel & spread  
 Rock the boat, swing thru, girls trade,  
 Cross the ocean, boys run, wheel and deal  
 Left allemande...

Heads square thru four, slide thru  
 Rock the boat, swing thru, right & left grand  
 On the third hand, promenade...

Heads pass the ocean, swing thru  
 Scoot and relocate, extend, swing thru  
 Same sexes trade, right and left grand...

Heads right and left thru, cross the ocean  
 Scoot and relocate, recycle, pass thru  
 Swing thru, right and left grand...

Heads lead right and circle to a line  
 Reverse flutter wheel, cross the ocean  
 Boys run, bend the line, flutter wheel  
 Rock the boat, recycle, left allemande...

Heads rollaway, sides half square thru  
 (Ocean wave) ends trade, centers trade  
 Swing thru, centers run, bend the line  
 Rock the boat, single hinge  
 Right and left grand...

**FIGURES FROM THE PAST**  
 by Frank Lane

Four ladies chain, heads spin the top  
 Turn thru and circle four, head men break  
 To a line, pass thru, ends crossfold, square thru  
 Bend the line, pass thru, wheel and deal  
 Girls square thru  $\frac{3}{4}$ , with the men  
 Left square thru  $\frac{3}{4}$ , boys turn back  
 Two ladies chain, follow her back with a  
 Dixie chain, girls go left, boys go right  
 Allemande left and promenade  
 Girls roll back and promenade  
 Heads wheel around, right and left thru  
 Turn thru, step up to the next two and do-sa-do  
 Pass thru, centers arch and ends turn in  
 Right and left thru, turn thru, split the sides  
 Make a line, pass thru, centers arch and  
 Ends turn in, on a double track, dixie style  
 To a wave, left swing thru, left allemande...

Side ladies chain to the right  
 Sides half square thru, circle four  
 Side men break to lines, right and left thru  
 Slide thru, swing thru, girls circulate  
 Boys trade, right and left grand...

Heads star thru, everyone double pass thru  
 First couple left, next right, right & left thru

Two ladies chain, dixie style to a wave  
Left swing thru, cast off  $\frac{3}{4}$ , all 8 circulate  
Left allemande, promenade  
Sides wheel around, two ladies chain  
Star thru, inside arch and dive thru  
Right and left thru, two ladies chain  
A full turn to face the outside two  
Circle four, sides break to a line, pass thru  
Wheel and deal, double pass thru, cloverleaf  
Substitute, dixie grand, left allemande...

Heads right and left thru, slide thru  
Pass thru, swing thru, girls circulate  
Boys trade, turn thru, left allemande  
Promenade, girls roll back, promenade  
Sides wheel around, two ladies chain  
Chain back dixie style, all eight circulate  
Left allemande...

Side ladies chain, sides promenade half  
Lead right and circle to a line, pass thru  
Wheel and deal, centers turn thru  
Left turn thru, centers turn thru, centers in  
Cast off  $\frac{3}{4}$ , pass thru, wheel and deal  
Boys turn thru, all left turn thru  
Centers turn thru, centers in, cast off  $\frac{3}{4}$   
Pass thru, wheel and deal, centers turn thru  
All left turn thru, centers turn thru, centers in  
Cast off  $\frac{3}{4}$ , bend the line, right and left thru  
Girls step across, left allemande...

Side ladies chain, heads star thru, substitute  
Right and left thru, substitute, pass thru  
Right and left thru, swing thru  
All eight circulate, left allemande...

Four ladies chain, rollaway, heads pass thru  
Separate go behind the sides and box the gnat  
Everybody right and left grand...

Allemande left, alamo style, swing thru  
Go forward two, left swing thru  
Go backward two, left allemande...

Heads swing thru, spin the top, pass thru  
Swing thru, spin the top, slide thru  
Left allemande...

Heads square thru four, swing thru  
Girls circulate, boys trade, swing thru  
Boys circulate, girls trade, swing thru  
Girls circulate, boys trade, turn thru  
Left allemande...

Four ladies chain, sides right and left thru  
Head promenade  $\frac{1}{2}$ , in the middle do-sa-do  
Sides divide and slide thru, heads pass thru  
Swing thru, boys run, couples circulate  
Wheel and deal, dive thru, swing thru

Boys trade, turn thru, left allemande...

Heads right and left thru, pass thru  
Both turn left, single file around two  
Into the middle, boys lead, dixie style  
To a wave, pass thru, circle four, ladies break  
To lines, pass thru, turn back, dixie style  
To a wave, then straight ahead left allemande  
Promenade, heads go single file, sides wheel  
To the middle, slide thru, square thru  $\frac{3}{4}$   
Left allemande...

Four ladies chain  $\frac{3}{4}$ , sides swing thru  
Spin the top, pass thru, spin the top  
Spin it again, pass thru, centers spin the top  
Spin it again, spin it again, pass thru  
All turn back, circle eight, girls forward & back  
Lead right, left allemande...

---

### RED BOOT BOYS

It has been learned from caller Wayne McDonald that the popular Red Boot Boys are no longer affiliated with English Mountain Retreat in Tennessee.

---

*Your pin-on  
badges need...*



*—to protect clothing  
from pin holes  
and tears*

---

*At Your Square Dance Shop  
and Badge Maker*

DEALERS: Call or write for brochure

**BADGE HOLDERS, INC.**

(415) 783-8724

24813 BROADMORE AVE.  
HAYWARD, CA. 94544

## P.S.: MS/QS

by Walt Cole

### TIMING'S THE THING (A BREAK):

INTRO: : Heads promenade 1/2  
Sides — right & left thru : — — — —  
Sides — touch 1/4 : — — Boys run  
— — Swing thru : — — — —  
Boys trade — — : Spin chain thru — —  
Boys circulate once : — — — —  
— — — — : Take corners, promenade  
— — — — : — — — —  
— — — — : — — — —

### FOR THE MODULAR CALLER:

Zero line: Spin the top, girls circulate  
Boys trade, Boys run, bend the line, slide thru  
Square thru 3/4, trade by...zero box

Zero line: Pass thru, wheel and deal  
Double pass thru, centers in, cast off 3/4  
Lines forward and back, center four spin the top  
Ends box the gnat, grand right and left...

Zero line: Pass the ocean, spin the top  
Boys run, wheel and deal, right and left thru  
Pass the ocean, girls trade, spin the top  
Single hinge, boys run, square thru 3/4  
Left allemande...

Static square; Heads square thru, centers in  
Centers run, touch 1/4, boys run...zero box

Static sq.: Heads star thru, double pass thru  
Centers in, centers cross fold, left allemande...

### THE BASIC PROGRAM

#### Cross run:

Zero box (wave): Girls cross run, girls circulate  
Boys trade, boys run, bend the line  
Star thru, left allemande...

Zero box: Swing thru, boys cross run  
Boys circulate, girls trade, girls cross run  
Grand right and left...

Zero box: Swing thru, boys run  
Couples circulate, girls cross run and circulate  
Boys trade and U-turn back (wave), boys run  
Wheel & deal, square thru 3/4, left allemande...

Static square: Heads pass thru around one  
To a line, pass thru, wheel and deal  
Double pass thru, girls U-turn back, touch 1/4  
Boys trade, girls trade, girls run, bend the line,  
Touch 1/4, boys run, left allemande...

### THE MAINSTREAM PROGRAM:

Zero line: Pass thru, boys fold, touch 1/4  
Boys trade, boys run, bend the line, pass thru  
Girls fold, touch 1/4, girls trade, recycle  
Veer left, couples circulate, boys run  
Box the gnat, pull by, left allemande...

Static square: Heads star thru, zoom  
Centers right and left thru, centers flutter wheel  
Double pass thru, cloverleaf, zoom, swing thru  
Turn thru, left allemande...

Static square; Heads touch 1/4, walk and dodge,  
Pass thru, outsides cloverleaf, centers touch 1/4  
Walk and dodge, pass thru, trade by  
Left allemande...

Zero box: Swing thru, boys run, tag the line  
Girls U-turn back, star thru, couples circulate  
Ferris wheel, square thru 3/4  
Left allemande...

Zero line: Right and left thru, Dixie style  
To ocean wave, boys cross run, boys circulate  
Girls trade, recycle, spin chain thru  
Girls circulate one place, boys run  
Bend the line, slide thru, left allemande...

Zero box: Square thru, boys run right  
Scoot back, boys fold, girls square thru 3/4  
Star thru, ferris wheel, zoom  
Square thru 3/4, left allemande...

#### Interesting:

Zero box: Touch 1/4, scoot back, boys run  
Pass thru tag the line, cloverleaf  
Centers turn thru, split the outsides  
Around one to a line, Left allemande...

Static square: Heads star thru  
Double pass thru, peel off, ends fold  
Touch 1/4, centers trade, scoot back, boys run  
Star thru, pass thru, trade by, left allemande...

Zero line: Pass thru, wheel and deal  
Double pass thru, centers in, cast off 3/4  
Pass thru, centers cross run  
New ends star thru, centers partner tag  
Swing thru, boys run, bend the line  
Crosstrail thru, left allemande...

Zero line: Pass thru, centers cross run  
New centers partner trade, centers square thru  
Ends star thru, centers in, cast off 3/4  
Centers square thru, ends star thru  
All pass thru, left allemande...

Zero line: Pass thru, tag the line in, pass thru  
Centers cross run, new centers cross run  
Box the gnat, fan the top, recycle  
Square thru 3/4, left allemande...

# THE BILL PETERS CALLERS GUIDEBOOK SERIES



## THE MIGHTY MODULE

**Book 1B**

Learn to use modules as a primary patter building tool. Clearly written text covers the dynamics of zeros, equivalents, get-ins, get-outs and conversions, and shows how to combine them using building block and "mix and match" techniques. . . . . \$7.95



## MODULES GALORE

An extra large collection of choreographic modules that has been especially designed to serve as a supplement to *The Mighty Module*. Contains over 1000 dancer tested modules personally selected by the author. . . . \$6.95



## SPECIAL COMBINED VOLUME

Two of the books in this guidebook series—*The Mighty Module* and *Sight Calling Made Easy* are combined and bound into a single money-saving volume. . . . . \$13.95

Order postpaid by sending check or money order to:

**BILL PETERS, P.O. Box 10692, Zephyr Cove NV 89448**

Canadian or overseas orders, U.S. Funds please. Add \$3.50 for Air Mail.

## ◀ ◀ THE BIG 11 ▶ ▶

### 11th BERMUDA SQUARE & ROUND DANCE CONVENTION at Beautiful SONESTA BEACH HOTEL

THURSDAY, FEBRUARY 15...TO...THURSDAY, FEBRUARY 22, 1990

*Take A Winter Break—Or A Long Weekend—Or The School Vacation!*

(Note New Dates)

#### CALLERS

Jim Purcell, Mass.

Carl Hanks, Pa.

Bob Silva, Mass.

Jim Lee, Ontario, Canada

#### CUERS

Richard & JoAnne Lawson, Ala.

Norma Silva, Mass.

Betty Hanks, Pa.

Shelly Lee, Ontario, Canada

★ THREE HALLS (PLUS, A-1, A-2)—ROUNDS IN EACH HALL

FOR REGISTRATION FORMS AND FULL INFORMATION:

BERMUDA S/D CONVENTION, PO BOX 145, AVON MA 02322 (617)963-0713

NEWS  
FROM

# CALLERLAB

THE  
INTERNATIONAL  
ASSOC. OF CALLERS

## SQUARE DANCING—BUILDING A FUTURE!

Is it worth a few pennies to help build your future and the future of the square dance activity? Some wonderful things are happening *right now* to assure that the future of the square dance activity continues, but more help is needed!

The Callerlab Foundation for the Preservation and Promotion of Square Dancing is having three 20/30-second Public Service Announcement (PSA) videos produced by top quality people in the business of award-winning commercials for you! Exciting, isn't it? This plan is coming together with your help! These videos will be completed in time for your next square dancing season. You can use

them at your local TV stations to promote your classes or special demonstrations and since they are PSA's, the stations should not charge you. Great, isn't it?

These PSA's are for callers, clubs and dancers to introduce the non-dancing public to the wonderful square dance activity and to help your clubs grow.

Imagine, if you will, a dimly lit room with a flickering light from a TV and the sounds of horses, cowboys, shooting and street sounds in the background, and two "couch potatoes" sitting with sad faces and junk food all around, and an announcer saying, "Are you having fun yet?" The scene dissolves into another scene of colorful square dancers smiling, having fun. Then the camera focuses on these same couch potatoes now in square dance attire and with big smiles and happily dancing. The announcer now says, "Come on! All American is coming home to good time—square dancing! It's good, clean fun!"

At the end, you can insert the appropriate tag to fit your area—"For more

Continental Square's U.S.A.-CAN.-MEX.

PRESENTS

# Tibet

# #5

# China Square Dance Grand Tour

SEPT. 15 - OCT. 3, 1989  
49 DAYS

TOUR LEADERS

SQUARE DANCE ACTIVITIES  
CULTURAL EXCHANGE  
WITH  
CHINESE DANCERS' ASSOCIATION



**NITA PAGE**  
DIRECTOR  
CONTINENTAL SQUARES



**JON JONES**  
INTERNATIONALLY KNOWN  
CALLER/ENTERTAINER

- OVERNIGHT IN TOKYO
- BEIJING (PEKING)
- GREAT WALL OF CHINA
- XI'AN
- CHENGDU
- LHASA - TIBET
- GUILIN
- HONG KONG

FREE BROCHURE

Send *China* Brochure

*Journey of a Lifetime*

MAIL TO: PAGE TOURS, 39120 Argonaut Way, Suite 409  
Fremont CA 94538 415-796-0500

NAME \_\_\_\_\_

ADDRESS \_\_\_\_\_



information on how you can learn to square dance, contact: (insert your club and/or number to be reached).

Or are you more sophisticated? Imagine a professional person seated in a high-back chair in front of bookshelves and speaking in an Oxford "upper-crust" accent explaining that square dancing is not what some perceive it to be—an activity of mindless people ahootin' and ahollerin' wearing jeans and dancing in the cornfields. The announcer continues to talk but now tells it like it is, with the music and picture dissolving in to scenes of modern western square dancing. The announcer says, "Come on! All America is coming home to square dancing! Your American heritage has come of age." (Information to contact inserted here to fit your area.)

How about tugging at the old American heartstrings—Americana—a series of pans, wipes and zooms dissolving into scenes of countrysides, big cities and people representing various occupations. The announcer says, "Are you looking for

a good time?" Again we dissolve into scenes and music of modern western square dancing and the announcer says, "Come on! All America is coming home to a good time! Square dancing—it's good, clean fun!"

How can you help? Easy! Any square dancer or group can contribute. Note that these contributions are not tax-deductible even though the Callerlab Foundation is tax exempt under IRS 501C(6)!

Have a special Building A Future Dance—add 50¢ or \$1 to the ticket price, but be sure to explain what the money is for! Try Barbara Kugler's Couch Potato dance idea and collect donations.

Dancers all over the world can use these PSA's by changing some of the wording.

Please contact Callerlab for further information on how to get your copy of these PSA's. Cost will be minimal but will cover cost of reproduction and distribution.

This is your chance to contribute to help build your future now... and for future generations of square dancers!"

THE  
**SQUARE  
DANCERS  
CLOSET**

**MARILYN  
ADAMS**

2012 Warren Ct.  
N. Augusta, SC 29841  
(803) 279-3687

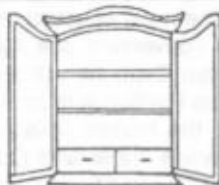

#513

**\$56.00**

Sizes 6-20



Fresh as Spring! This new treatment of duco dot fabric has middy braid trim on a flattering square neckline, sleeve ruffles, and skirt ruffle. A style that looks great on all gals! Washable.

Colors:

White background with royal  
White background with red

**NEW SPRING 1989  
CATALOG  
NOW AVAILABLE!**

\$1.00 Each • Relunded with  
your first order.

Send for your copy TODAY!



**Ordering Information**

Please send with order — style, size, color, price, your name, address, city, state, zip & telephone number. For charge purchases please send charge card number, name printed on card & expiration date. \$3.00 shipping. Additional freight required on Canadian, APO, Alaska & Hawaii. South Carolina customers please add 5% sales tax.



## COAST INTO VANCOUVER

The committee for Canada's National S/D Convention in Vancouver on July 26-28, 1990, invites you to "coast into Vancouver." The host city nestles between the soaring North Shore mountains and the Fraser River Valley at the western edge of the Pacific Ocean. It started 100 years ago as a tiny settlement and has grown to include diverse neighborhoods—"Little Italy" and the second largest Chinatown in North America. Summers are warm with a 75° average, coaxing along the gardens of Stanley Park, the largest in any North American city.

The most spectacular new building is the convention site itself. Anyone who visited Expo 86 will remember Canada Place Pavilion with its five sails jutting out into the harbor. This has become Vancouver's Trade and Convention Centre, the air-conditioned multi-level centre where the convention will take place. Easy access to the Centre by car, boat and plane combine with a low crime rate and a spotlessly clean city to provide you with a relaxing vacation.

For information, write PO Box 2625, Vancouver BC, Canada V6B 4W8.

## NEWS FROM NEW ZEALAND

Happy Feet Squares of Whangarei is having a birthday dance weekend April 8-9. Art Shepherd from Christchurch is the guest caller. The level will be Mainstream.

Any dancers who are visiting New Zealand anytime are welcome to visit the club. Contact Eric White and Patricia Harbord, 48 Weaver St., Whangarei, New Zealand. Phone: 089-71127.

## MISSISSIPPI GULF COAST

TWENTY-SEVENTH ANNUAL

### Square Dance Festival

August 4 & 5, 1989



### MISSISSIPPI COAST COLISEUM

Marshall Flippo.....Friday  
 Beryl Main & Scott Smith.....Saturday  
 John & Wanda Winter.....Rounds  
 Harold Smith, 4502 Kendall Ave., Gulfport MS 39507

### NO SINGLES CLUB IN YOUR AREA?

Let us help you start a local Chapter of Bachelors 'N' Bachelorettes International.

Become affiliated with the largest SINGLES' Square Dance Club in the world! Over 50 Chapters currently and continuing to grow!

#### WRITE NOW FOR INFORMATION!

Bachelors 'N' Bachelorettes International, Inc.  
 c/o Bob Wildman, International President  
 3338 Perlita, Los Angeles CA 90039  
 Phone 213-663-4618

### SQUARE DANCE LEADERS CALLERS, CUERS, CONTRA

Send for Free Copy  
 CALLERS NOTE SERVICE  
 CALLERS LIABILITY INSURANCE  
 NATIONWIDE CALLER REFERRALS

MEMBERSHIP AVAILABLE  
 "Oldest & Best"  
 NATIONWIDE

SOUTHERN CALIFORNIA CALLERS ASSOC., INC.  
 4819 West M-12, Quartz Hill CA 93536  
 805-943-6984



### WE DESIGN CLUB BADGES

1 line "Slim Jim"	\$1.25
Name only, Regular Size	\$1.35
Name and Town OR Design	\$1.50
Name and Town and Design	\$2.00
Name, Town, Design, Club Name	\$2.25
State Shape	\$2.75 & Up

\$5. Minimum Order  
 Badge Colors: Black, white, blue, green, brown, red, yellow and walnut

Orders \$10.00 or less, add \$1.00. Orders over 10.00, add \$2.00.

Thank you  
 MICRO PLASTICS  
 PO Box 847  
 Rifle CO 81650  
 Tel: 303-625-1718





## Sing Along with Don Malcom

### Singing Call Book

Over 300 M.S. Modules ... \$16.00ppd

NOTE: This is the only book available today with all figures properly timed to the Callerlab Standard.

#### LEAD RIGHT CALLER NOTES

\$22.00 Yearly.....FREE Samples

Don Malcom, RR 2 Box 87, Sheldon MO 64784

Phone: 1-417-884-2763

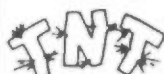

### The Best in Square & Round Dance Music All Rounds Cued

TNT265 HAPPY MORNING (Rd), G. Kammerer

TNT266 RIDING ON A CLOUD, by Dan Faria

TNT267 TENNESSEE HOEDOWN/  
ALL NIGHT HOEDOWN

TNT268 YOU'VE CHOSEN ME by Wynne Mahler

TNT269 STAGGER LEE by Mike Iavarone

TNT270 THE LOCO-MOTION by Mike Iavarone

MODERN STYLE CONTRA PARTY

LP1001—Dick Leger \$5.+.75 pst.

Plastic Record Sleeves Available

Quantity Discounts for 25, 50, 100 & 1000

RFD 2 Rt. 7, St. Albans VT 05478, 802-524-9424

## CHOREOGRAPHY VIDEO SIGHT CALLING VIDEO

By ED FOOTE

Well-Known Caller Instructor

Each Color Video about 90 Minutes Long.  
Presentations are Organized & Complete.

\$49.95 - 1 Tape

\$79.95 - Both Tapes

Order From: Dale Garlock

2107 Shunk Ave.

Alliance, Ohio 44601



## DIDACTIC DANCE CALLERS/CUERS

The Spirits, an exhibition square dance group from Houston, Texas, sponsored the first annual Didactic Dance last November. The two \$500 scholarships went to Billy Vaughn and Ron and Patricia Cox, who will receive the awards when they attend caller/cuer schools of their choice in 1989. For four hours, 35 squares of dancers were treated to the calling and cueing of some of the Houston area's most popular and able callers and cuers, who donated their time and talent to make this a successful occasion. Dancers came from as far as 150 miles away. The more than 400 squares of dancers in Houston will benefit for years from this educational endeavor.

The Spirits hope this will be an annual event, and their planned date for 1989 is November 5. *Otto Warteman*

## BERMUDA CONVENTION

Another successful Bermuda Convention took place in January, 1989, with a festive atmosphere, a Happy Tenth Anniversary banner in the ballroom, and sunny skies and gentle breezes all week. Before the first night dance, Jim and Gerrie Purcell presented jackets to staff members, and a candle-lighting ceremony, with the dancers who had attended all ten conventions taking part, launched the affair. Two couples who attended all the conventions are Lee and

### PROMENADERS

Clog & S/D Shoes  
Blk & Wht \$32.95  
Colors

Gold & Sil. \$34.95  
P&H add \$2.50



Tel. 919-778-0476

### SOPHIA T'S

Square Dance & Western Wear Fashions, Inc.  
Eastern N.C.'s Largest Square Dance Shop  
Route 9, Box 273A • Hwy. 70 East  
Goldboro, North Carolina 27530

CLOGGER for men (black & white)

CLOGGER for women (white only)

\$34.50

We Ship Anywhere in the World

Brochure available—\$2.00 (refunded on first order)

Checks, MasterCard, Visa, American Express



Linda Reed of Maryland, and Roger and Nancy Remington of New Jersey. The oldest dancer, at age 81, was George Puddington from New Brunswick, who was attending for the first time. 20 states and five provinces were represented by the 175 dancers present. Callers were Gary Brown, Carl Hanks, Clint McLean, Bob Silva and Jim Purcell. Cuers were Betty Hanks, Richard and Jo Anne Lawson, and Norma Silva.

*Hank Katten  
West Haven, Connecticut*

### LETS—OCTOBER, 1988

66 dancers converged on Cave City in the heart of Kentucky's Cave Country to learn how to be better leaders and to find ways of bettering not only their local clubs but the square dance movement in general. This was the Leadership Educational Training Seminar of the Kentuckiana S/D Assn. Directors were Frank and Mary Ann Trapp of Camden, S.C. The LETS Committee was composed of Frank and Amelia Pearce, Bill and Doris Rose, Carl and Nina Richie, Bob and Louise Boston, Roger and Lola Dannenfelser, Ed and Betty Conner.

### IN MEMORIAM

Mary L. Marè passed away on January 30 after a year-long battle against cancer. Her husband George is a caller and she was a faithful helper and a member of the Schoharie Valley Hayshakers. George and Mary had five children.

Jim Harper, co-chairman of the 34th National Convention in Birmingham, Alabama, died December 31. He and his wife Juanita held many positions in square dancing in Alabama, from club president to the state wide offices, culminating in their choice as general chairmen of the National Convention. Jim's death will also leave another empty chair on the National Executive Committee of the Conventions.

Caller Harold Illian passed away in December in Cincinnati after a 35-year career in calling. His wife, Gertrude, passed away in 1986. Harold was a dedicated caller who loved the activity.

Gene Webster, a caller in Mishawaka,

## LASRY COLLEGE FOR CALLERS

English Mountain Resort  
Sevierville, Tennessee

July 30-August 1, 1989

**Staff**

**Jack Lasry—Earl Johnston**

Limited to 20 Callers: 10 Experienced, 10 Newer

Write: Jack Lasry, 1513 No. 46 Ave.

Hollywood FL 33021 or Phone 305-981-7788

24K Gold-Plated Enameled

### SQUARE DANCE JEWELRY

P. Earrings or Pendant \$3.95

Both for only \$6.95

plus \$1.00 ship. & handling  
(Calif. res. add 6% sales tax)

Earring also available  
with clips.

When ordering specify dress

color: red, blue or black.

Send check or money order to

**Charmz-Reaction**

P.O. Box 4208

West Hills CA 91308



## The Ferris of Them All

30th Wisconsin  
Square & Round Dance Convention

August 25-27, 1989  
Stevens Point, Wisconsin

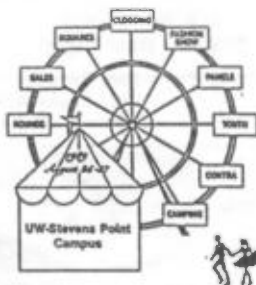

## POINT IS FINE IN '89

Contact: Mike & Judy Hampton  
Registration Chairpersons  
708 Second Street  
Stevens Point WI 54481  
715-345-0780

## CALLING ALL CALLERS

### INTRODUCING THE ALL NEW EQUIPMENT BOX COVERS

Designed exclusively for the Square Dance Caller  
Our covers offer protection with a professional look.



\$84.00  
per set

- Machine Stitched
- 32 oz. Quilted Black Vinyl
- Velcro Closing
- Handle Opening for Easy Carrying
- PATTERNS FOR:
  - Supreme 8-82 Speaker
  - Supreme S40 Speaker
  - Supreme Mini-Speaker
  - Hilton 300
  - Hilton 75 A & B
  - Hilton Folded Sp-eaker SS-ALT
  - Hilton Record Case
  - Ashton Amp
  - Yak Speaker & 1/2 Yak Speaker

Caller  
Gift Idea

J & J Upholstery  
Golden Strip Shopping Center  
Mauldin, South Carolina 29662  
Phone (803) 288-4000

Indiana, and Port Clinton, Ohio, who moved to the Los Angeles area several years ago, passed away on January 24.

Donald R. Gregory of Mountain Home, Idaho, passed away in January of Lou Gehrig's disease. D.R. Gregory danced in England and called throughout Europe, as well as in the western U.S. He held many offices in Idaho S/D organizations and was a member of Callerlab.

### DANCING TIPS, Continued

(which I did a few times accompanied by knocking knees and shaking head), I "became" the character out of the book. This method worked so well for me that eventually I was much in demand to give demonstration hour-long book reports to all the English and Speech classes.

So, if you are too shy to greet other dancers, and especially newcomers, you can project yourself as that enviable, most sociable creature you know from the club or elsewhere in life. It's just a little mental trick so you don't put your own ego on the chopping block. If you make a blunder, it won't really be "you," it will be this other character you plucked out of your imagination. With a little luck and practice, this friendly "character" may be incorporated into your fulltime personality.

Dancing with newcomers is a great ice breaker. Wives can use their husbands to help master this technique. Have your husband suggest to the visiting couple that you switch partners for the next tip.

Any time your club has visitors, make it your first priority to switch partners with the visitors sometime during the evening. Don't let the evening end without extending an invitation for the visitors to come back and visit. Let them know how much you enjoyed the opportunity to meet them.

Make a little label for yourself and wear the invisible aid with you to each dance. Have it say *Official Club Greeter*. Hold that unofficial office for as long as you hold membership in any club. Don't be surprised if you find it to be the most rewarding office you have every held.



MIKE



BARB

Capezio

Only \$24<sup>90</sup>

#550



"RINGO"  
By Coast

Only \$26<sup>90</sup>



BLK - TAN N.M.W.  
- WHT - RED WIDTHS

Write for **FREE** Catalogue  
featuring **DISCOUNT** Prices  
on Coast & Capezios.

SEND WITH ORDER:

- Style ● Color ● Size ●
- Width ● Price
- Your Name, Address,
- City, State, Zip
- Add \$2.50 per pair for P/H
- Check, Visa, MasterCard
- Accepted

MAIL TO:

Mike and Barb's  
SHOE SHOP  
420 David Drive  
No. Syracuse NY 13212  
315-455-8362



# People

IN THE NEWS



From **Mary Stanley**, we learned that 48 dancers graduated in November at a special ceremony/dance of the Cathedral Squares of Christ-church, New Zealand, held at Cathedral College Gymnasium and attended by 23 squares. The caller tutors were **Art and Blanche Shepherd, Kelvin and Janette Love, Alex and Susan Stevens**. The new dancers presented **Blanche, Janette and Susan** with beautiful flower arrangements.

Callers **Stefan Sidholm and Ingvar Pettersson**, recording artists for Sting Records in Sweden, called five dances in the greater San Francisco area in March. Dances were held in Belmont, Dublin, Palo Alto, Petaluma and San Jose. The two young Swedish callers returned to the U.S. for the Callerlab Convention in Nashville. Their tour also took them to the Seattle and Vancouver areas, according to **James R. Ozanich**.

Handicapable benefactor and caller, **Warren Berquam** of Maple Plain has been honored as an "Eleven Who Care" winner for his volunteer activities in the state of Minnesota. The telecast for the award presentation ceremony was in March at the Hyatt

Regency Hotel in Minneapolis.

A big dance party was held recently to honor the Golden Wedding Anniversary of caller **Eric and Dot Wendell** of Hawthorne, Australia.

Caller **Johnnie Wykoff** (Blue Star) of Houston, Texas, is celebrating his fortieth year of calling.

Round dance leader **Norma Wylie Buehman** was married December 29, 1988.

Get-well wishes are extended to caller **Bob Augustin**, who has contracted Lou Gehrig's disease and must curtail his activities.

Young caller **Laurel Eddy** of Macon, Georgia, is quoted in a *Go!* publication about the benefits of square dancing.



A gala New Year's Eve dance with the Apaches in Grenada Hills, California, featured callers **Mike Kellogg and Joe Saltel** and cuer **Finn Hoefler**. Photo by **Bob Messina**.

From **Charlotte Rugg** of Collins, N.Y., we hear that a special wave action pool dance was held in Pontiac, Michigan, called by **Doug Rieck**, and many dancers earned duck badges. Photos appearing in the *Detroit Free Press* featured **MarJo Scardino, Nick Menghini, Ronni Matarwe** and others.

Caller **Jim and Lessie Dife**y of Nevada City, California, recently took 26 square dancers to Russia on a cultural exchange program, where they danced with and for the Soviets on a 15-day tour. **Al and Arlene Yanney, Myrna and Neil Marshall**, others, are shown in *Villager* photos.

The *Seasons*, from Northern Cochise County in Arizona, gave a pictorial article to area square dancers, including members of the Box Car Squares, sent to us by caller **Gary and Berni Murphy**.

Cuer **Don Waldal** saved **Stella Cooley's** life twice, thanks to CPR training, once at the Wheel of Fortune R/D Festival in Las Vegas and once at the Anchorage S/R Dance Center in Anchorage, Alaska, according to a story in the *Anchorage Times*, sent to us by **Morris and Evelyn Turner**.



# "TRADE THE WAVE"



For a Weekend of Great Dancing

May 26 - 27, 1989



**Director**

Don & Pat Degner  
632 Caren Dr.  
Va. Beach VA 23452  
804-340-0999

**Registrar**

Ron & Sue Jennings  
11304 Blendon Lane  
Richmond VA 23233  
804-740-1893

## Pavilion

Virginia Beach, Virginia

Virginia Square and Round Dance Association

## First State Convention



## Steal a Little Peek

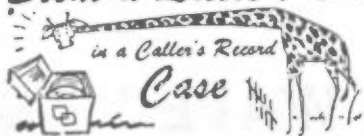

### BILL COOPER

Bill started dancing out west in his high school days. This and skating formed much of the social entertainment in those depression days. Bill met Barbara, his future wife, at a Friday the 13th Dance at McGill University in 1933. Dancing events were infrequent until moving to Toronto in 1949 to work for Ontario Hydro. In 1953, Bill learned to call and later the Coopers joined a square dance club which danced traditional squares and couple dances.

In 1959, the Fifth Atlantic S/D Convention was hosted in Toronto and Bill called in the Old Tyme Room. Here Bill and other Toronto callers and dancers became acquainted with western square dancing. The Swinging' Squares was formed, dancing rounds as well as squares. In 1967, a separate round dance club was formed called Harmony Q's. This year also, Bill was asked to call for the Alliston Swinging Eights.

Bill and Barbara are members of the Toronto and District S&R/D Assn., which they joined in 1959. They served as presidents for 1965-67 and were made honorary members in 1981. They are members



of both Callerlab and Roundalab. Bill is the author of *The Logical Teaching of S/D Basics*, and many articles. Recently Bill has been bringing dancing to senior citizens groups.

#### HOEDOWNS:

Chinese Breakdown  
Chordex  
Catie M  
Father O'Flynn  
Alpine Hoedown  
Boil That Cabbage Down  
Jersey Jig  
Gitdown No. 1

#### SINGING CALLS:

Best Things In Life Are Free  
Light in the Window  
Gentle on My Mind  
Wonderful and Grand  
When You're Smiling  
Everywhere You Go  
Summer Sounds

## ALLEMANDE SHOP

### RECORD TAPE SERVICE

P.O. BOX 8246 CHATTANOOGA, TN 37411  
1-800-346-4867 1-615-894-2655



**ONLY \$24 A YEAR**  
AND YOU KEEP THE TAPE!!



WRITE OR CALL NOW FOR FULL DETAILS...

# FACING THE L.O.D.

## LYLE AND FAYE LONG

Lyle and Faye were high school sweethearts and were married in 1957. Living close by their Waukesha, Wisconsin, home are their two married daughters, four grandsons and two granddaughters.

Having never danced a step before, in 1980 they began square dance lessons. The next fall they drove 140 miles round trip to take beginners' round dance lessons. Graduation came in the spring of 1982 and they cued their first dance on the following New Year's Eve. Beginners' lessons in their area were needed, and the next fall the Longs taught their first class. The following year they took and gave intermediate lessons. Two clubs, the Merry Go Rounders, one for Phase II and one at Phase III and IV, were born. Lyle and Faye think of their club members as personal friends.

Lyle cues regularly for six S/D clubs and guest cues for others. A schedule with only one free night a week led to semi-retirement. Faye is controller by day for a manufacturer in Waukesha, and round dance partner in the evening.

Lyle and Faye are currently presidents



of the Wisconsin R/D Leaders Council, in which they have been active since 1983. They are members of Roundalab, and have served as chairpersons of Wisconsin's annual Accent on Rounds. They have cued at every Accent and state convention during the past five years.

During the summer, they enjoy their motorcycle and make extended trips across the country to attend cuers' colleges, seminars and square dance weekends. You will also find them two weekends a year on staff at Feases' Shady Rest Lodge in Rhinelander, Wisc.

Lyle suggests that in order to have an active round dance club, one must be active at square dances and help to promote square dancing. He believes square dancing is the lifeblood of round dancing, and rounds are equally important to squares.



## Square Dance Patterns

We have the following brands in stock for immediate shipment:

Authentic ● C & C Originals ● Kwik Sew  
Ruffle Collection ● Fann Burrus

ENCLOSE \$1.00 FOR CATALOG

NAME \_\_\_\_\_

ADDRESS \_\_\_\_\_

CITY, STATE, ZIP \_\_\_\_\_

Double D Productions, Inc.

4110 WILLOW RIDGE ROAD, #50

DOUGLASVILLE, GA 30135

(404) 949-3648

# EUREKA RECORDS

## \* New Releases \*

### Singing Calls

- EUR 1201.....I Didn't , Bob
- EUR 1202.....Early In The Mornin', Bob
- EUR 1301.....Apple Blossom Time, Tom
- EUR 1302.....Let's Twist Again, Tom
- EUR 1902.....Dream A Little Dream,

Gary Carnes



**KIP GARVEY**

P.O. Box 8045  
Fremont, CA 94537  
(415) 792-7099



**BOB BAIER**

11750 So. Kirkwood  
Stafford, TX 77477  
(713) 933-0088



**TOM MILLER**

RD 1, Box 158  
Loretto, PA 15940  
(814) 886-2590

### New Hoedown

- EUR 2002.....Bobbie, Bill Davis  
(2-Couple Dancing--PLUS Calls)

### \* Other Hits \*

- EUR 1001.....One Step Forward, Kip
- EUR 1002.....One For The Money, Kip
- EUR 1003.....Sad Songs, Kip
- EUR 1004.....Hot Burnin' Flames, Kip
- EUR 1901.....Dancin' On The Ceiling  
Jerry Story/Tony Oxendine
- EUR 1006.....Shadows In The Moonlight, Kip
- EUR 1007.....Daddy's Hands, Kip

### Hoedowns

- EUR 2001.....Wildflowers/Flicker

*Ask Your Dealer To Keep  
EUREKA RECORDS  
In Stock For You.*

### Produced by:

Kip Garvey Enterprises  
P.O. Box 8045 Fremont, CA 94537 (415) 792-7099

# Caribbean Cruise Holiday

7-DAY

August 26-September 2, 1989

7-DAY

With the NEW ZEALAND KIWI MOUNTAIN SQUARE DANCERS

**Hosted By** RUSS and ELVA MAY LINDSAY JIM and BARB BLACKWOOD  
Tauranga, New Zealand Washington, Illinois

### VISITING 6 EXOTIC PORTS

SAN JUAN CURACAO CARACAS GRANADA MARTINIQUE ST. THOMAS

For more information, contact BLACKWOOD TRAVEL

118 South Elm St. Suite 101, Washington, Illinois 61571 Phone (309)444-8011



# FLIP SIDE-ROUNDS

At deadline time, the round dance record reviews had not been received. This column this month contains recent news received from the **Round Dancer** magazine.

## ROUND DANCER'S 1989 CLASSICS

1. Pop Goes the Movies (Raye) Arista AS0660
2. A Taste of the Wind (Eddins) MCA 52076
3. Crazy Eyes (Eddins) Millenium YB11819
4. White Sport Coat (Lefeavers) Col. HOF 13-33013
5. I Wanna Quickstep (Palmquist) Grenn 14261
6. Street Fair (Merola) Ranwood R916
7. Hallelujah (Reeder) Warner Bros. Curb 8877
8. Apres L'Entreinte (Dahl) Epic 8-50270
9. Distant Drums (Foxcroft) RCA 447-0785
10. Primrose Lane (Wilder) Goldisk G3049, Eric270
11. Tampa Jive (Macuci) RCA Gold Std GB12370
12. Hush (Croft/DeZordo) A&M8596S
13. Gazpacho Cha (Lawson) Dance Along P6108
14. Begin the Beguine (Wolcott) Roper 164
15. Jacalyn's Waltz (Wilhoit) Red Boot RB907

New classics for 1989 are: *White Sport Coat*, *Distant Drums*, *Tampa Jive* and *Jacalyn's Waltz*. New All-time Classic for 1989 is *Apres L'Entreinte*.

## FIRST 10 RUNNERS-UP

These runners-up do not carry the 1989 classic rating; however, they do warrant consideration for learning, teaching and programming.

1. Biloxi Lady (Eddins) Atl. Amer. 7-99700
2. Lazy Sugarfoot (Procter) Roper 309
3. Games That Lovers Play (Wolcott) Roper 176

4. Adios (Norman) RCA Victor 447-0716
5. Til Tomorrow (Palmquist) Windsor BR 4-537
6. Pagan Love Song (Pierce) Syd Thom EP 615
7. Good Ol' Girls (Eddins) Elektra E47129
8. Rainbow Foxtrot (Blackford) Telemark 912
9. Para Esto (Roberts) Telemark 916
10. Don't Cry For Me Arg. (Palmquist) IDTA 54

*Round Dancer Magazine* first presented choreographers with special awards for having their dances among the best of the Top Ten dances for a calendar year in 1982. Following are the round dance titles and their choreographers' names for 1988.

## BEST OF THE TOP TEN IN 1988

1. Fiddlestepper Polka (Brown) Wagon Wheel 811
2. Deja Vu (Eddins) Mercury 888 650-7
3. Snap Your Fingers II (Eddins) RCA 5169-7-R
4. Whoop De Do (Winter) Chaparral C609
5. East Strolling (Auria) Merry Go Round 43
6. Die Lorelei (Bendewald) Hi-Hat EN009
7. I'll Be the One (Jabour) Mercury 888 650-7
8. The Boy Next Door (Lehnert) MGR 49  
Twinkle Twinkle Lucky Star (Wilhoit) Epic 34-07631
9. Devil Woman (Raybuck) Columbia 13-33070
10. Turn It Loose (Crapo) RCA 5329-7-R

If you would like all ten cue sheets above in a special "best of the 1988 Top Ten Cue Sheet Package," it is available for \$4 from Round Dancer Magazine, RD 1 Box 843, Petersburg PA 16669-9304. Pa. residents should add 24¢ sales tax, and foreign add \$1.75 A.M. postage.



PO BOX 216

**GRENN**

BATH OH 44210

### Latest ROUND DANCE

GR17124 EDILWEISS, Waltz by Ruby & Perry Kullman, Solo-line dance by Bill Cooper

### REPRESSING

GR17064 VERY SMOOTH, Classic round by Harvey & Norine Wiese

VERY CHIC, Classic round by Caryll Hayden (on flip of cue sheet)

TOP25371 ORANGE BLOSSOM SPECIAL, Instrumental Hoedown

Bow Howell calls the flip side. Cue sheet updated for One-Night-Stand use.

### New ROUND DANCES to Old Grenn Records:

GR14169 CARELESS HANDS (While We Dance), Waltz by Al Goulet

GR14232 UNTIL THE STARS FALL, Waltz by Charlie Brown

CEM 37039 VAN ISLE SAMBA by Al & Dotty Brauer

# Flip Side SQUARES

## DANNY BOY—Blue Ribbon 247

Caller: Earl West

FIGURE: Heads promenade 1/2, lead right, right and left thru, veer left, couples circulate, bend the line, do-sa-do, star thru, pass thru, trade by, left allemande, swing, promenade.

## STRONG ENOUGH TO BEND—Blue Ribbon 248

Caller: Burlin Davis

FIGURE: Heads lead right, circle four to a line, right and left thru, touch 1/4, coordinate, bend the line, star thru, pass thru, trade by, swing, promenade.

## SMILE, DARN YA, SMILE—Blue Star 2373

Caller: Johnnie Wykoff

Key: G

Mainstream. FIGURE: Heads square thru, do-sa-do,

swing thru, boys run, tag the line, cloverleaf, ladies square thru 3/4, star thru, promenade.

## I'M JUST WILD ABOUT MARY—Blue Star 2374

Caller: Johnnie Wykoff

Mainstream. FIGURE: Heads square thru, do-sa-do, swing thru, boys run, tag the line right, wheel and deal, turn thru, left allemande, swing, promenade.

## MY GUIDING STAR—Blue Star 2375

Caller: Johnnie Wykoff

Key C-D

Mainstream. FIGURE: Heads promenade 3/4, sides square thru three, all slide thru, reverse flutter wheel, pass thru, partner trade and roll, pass thru, swing, promenade.

## YOU GO YOU'RE GONE—Circle D 236

Caller: Dean Crowell

FIGURE: Heads square thru, do-sa-do, swing thru, boys run, girls trade, half tag, walk and dodge, partner trade and roll, pass thru, U-turn back, swing, promenade.

## I'M GONNA SING—Chaparral 217

Caller: Jerry Haag

FIGURE: Heads square thru, do-sa-do, swing thru, spin the top, right and left thru, \*square thru 3/4, swing,

## A NEW WAY TO LEARN BY VIDEO TAPE

### GOLD STAR VIDEO PRODUCTIONS

P. O. Box 96, Roseville, CA 95661

(916) 782-1879, 331-2550



#### SQUARE DANCE TAPES

1. Basic #1 (1-23)
2. Basic #2 (24-49)
3. Mainstream
4. Plus
5. Singing Call



#### ADVANCED SQUARE DANCE TAPES

11. A-1 PART A
12. A-1 PART B
13. A-1 Dance Tips (Great Music)
16. A-2 PART 1
17. A-2 PART 2 (Coming Soon)

#### ROUND DANCE TAPES

6. Waltz Basic
7. Two-Step Basics — #1
8. Two-Step Basics — #2
9. Easy Level Rounds  
(6 Waltz, 12 Two-Step Routines)
10. Cueing with Harmony  
(11 Two-Step, 8 Waltz Routines)

#### GUITAR

14. Basic Guitar
15. Intermediate/Advanced Guitar

### ALL TAPES \$39.95

Prices Effective 3/1/89  
(\$3.50 for shipping, handling and insurance for each tape).

(Shipping and handling \$10 each tape outside U.S.A.)

Add 6 1/2 % sales tax if you live in California.

**SPECIFY:**  VHS  BETA

#### HOW TO ORDER

Send a check or money order (no cash please) payable to **GOLD STAR VIDEO PRODUCTIONS,**



promenade. Or, \*pass thru, chase right, swing what you chase and promenade.

**DEEPER THAN THE HOLLER—Cross Country 511**

**Caller: Shane Greer**

FIGURE: Heads square thru, do-sa-do, linear cycle, reverse flutter wheel, dixie style, boys cross run, girls trade, boys run, promenade.

**PANCHO AND LEFTY—Cross Country 512**

**Caller: Bob Wilcox**

FIGURE: Heads promenade 1/2, sides pass the ocean, recycle, double pass thru, peel off, star thru, cloverleaf, centers swing thru, turn thru, swing, promenade.

**RHYTHM IS GONNA GET YOU—ESP 710**

**Caller: Craig Rowe**

FIGURE: Heads promenade 1/2, pass the ocean, extend, swing thru, boys run, tag the line right, ferris wheel, pass thru, swing corner, promenade.

**LITTLE GIRL—ESP 157**

**Caller: Elmer Sheffield**

FIGURE: Heads square thru, do-sa-do, spin chain thru, girls circulate two, turn thru, left allemande, walk by one, swing, promenade.

**I HEAR THE SOUTH CALLING ME—Hi-Hat 5113**

**Caller: Tom Perry**

FIGURE: Heads square thru, do-sa-do, swing thru, boys run, couples circulate, chain down the line, star thru, pass thru, trade by, swing, promenade.

**THAT OLD WHEEL—Jo-Pat/ESP 232**

**Caller: Joe Porritt**

Mainstream. FIGURE: Heads star thru, pass thru, do-sa-do to a wave, ladies trade, recycle, veer left, ferris wheel, right and left thru, centers pass thru, touch 1/4, scoot back, swing corner, promenade.

**BOOGIE SHOES—LouMac 170**

**Caller: Tommy Wells**

FIGURE: Heads square thru, do-sa-do to a wave, girls trade, recycle, star thru, right and left thru, square thru 3/4, swing, promenade.

**DANCIN' SHOES—Quadrille 861**

**Caller: Art Springer**

FIGURE: Heads promenade 1/2, pass the ocean, extend, swing thru, boys run, chain down the line, star thru, pass thru, left allemande, swing, promenade.

***Keep 'em Squared Up with Hi-Hat & Blue Ribbon Dance Records***

***Brand New on Hi-Hat & Blue Ribbon***

- HH 5115 — JUST ANOTHER POLKA by Ernie Kinney
- HH 5114 — SHE'S GOT LEAVIN' ON HER MIND by Dave Abbott
- BR 250 — WHINE YOU WHISTLE, WHINE by Dan Cucore
- BR 249 — HAVE I STAYED AWAY TOO LONG by Bill Stone

***RECENT BEST SELLERS ON HI-HAT & BLUE RIBBON***

- HH 5113 — I HEAR THE SOUTH CALLIN' ME by Tom Perry
- HH 5112 — I LOVE YOU MORE AND MORE EVERY DAY by Ernie Kinney
- HH 5111 — BRING BACK by Dave Abbott
- HH 5110 — SWEET DREAMS OF YOU by Bronc Wise
- BR 248 — STRONG ENOUGH TO BEND by Burlin Davis  
(Also Available with Harmony)
- BR 247 — DANNY BOY by Earl West

***ELK RECORDINGS AND TAPES AVAILABLE FROM PRODUCER***

**PRODUCER: Ernie Kinney Enterprises**

**3925 N. Tollhouse Rd., Fresno CA 93726, Phone 209-227-2764**

**HI  HAT DANCE RECORDS**

**DO THE LOCOMOTION—Ranch House 223**

Caller: Darryl McMillan

FIGURE: Heads promenade 1/2, square thru, right and left thru, veer left, couples circulate, half tag, scoot back, swing corner, promenade.

**BEAUTIFUL DAY—Royal 701**

Caller: Kip Garvey

FIGURE: Heads promenade 1/2, touch 1/4, walk and dodge, swing thru, boys run right, bend the line, right and left thru, slide thru, square thru 3/4, swing, promenade.

**A DAY LATE AND A DOLLAR SHORT—Royal 502**

Caller: Larry Letson

FIGURE: Heads square thru, right-hand star, heads star left, same corner, do-sa-do, star thru, boys scoot back, girls dodge, swing, promenade.

**GET ME BACK TO DIXIE—Solid Gold 301**

Caller: Nick Hartley

FIGURE: Heads promenade 1/2, square thru, right and left thru, veer left, ferris wheel, centers square thru 3/4, swing, promenade.

**I'M MADE FOR DANCING—Solid Gold 201**

Caller: Tom Manning

FIGURE: Heads promenade 1/2, right and left thru, square thru, do-sa-do, eight chain four, swing, promenade.

*PATTER RECORDS:*

**WITH/WITHOUT—Blue Star 2376**

**BLUE BLUE DAY—Shakedown 203**

Don McWhirter calls on the flip side.

**HOEDOWN BLUES—Shakedown 204**

Burt (Red) Cullopp calls on the flip side.

**UNVEILING CHANGED IN OK CITY**

Pete Hughes called to say the unveiling of the square dance statue (see *ASD* March '89, p 39) has been changed to Wednesday night, June 21, 8:30 PM at the fairgrounds, instead of Thursday morning as previously reported. Don't miss this historic event as part of the festivities of the National S/D Convention.

# KALOX-Belco-Longhorn



Jon Jones



Bill Harrison

*NEW ON KALOX:*

**K-1316 THAT'S WHERE MY WOMAN BEGINS**, Flip/Inst. by Tom Miller

*RECENT RELEASES ON KALOX:*

**K-1314 THINK IT OVER**, Flip/Inst. by Bill Harrison

*LONGHORN:*

*RECENT RELEASES*

**LH-138 TWO TIMIN' BLUES**

**LH-144 BALLIN' THE JACK**

*POPULAR RELEASES STILL AVAILABLE*

**LH-193 FREEDOM**

**LH-194 FIRE BALL MAIL**

**LH-1022 GOODNITE LITTLE GIRL**

*NEW ROUNDS ON BELCO:*

**B373A I LOVE YOU SO MUCH**, Foxtrot by Richard & JoAnne Lawson

1. Music Only; 2. Cues by Richard

**B-373B SWEET NAOMI**, Two-step by Joe & Alice Hill

1. Music Only; 2. Cues by Charlie Proctor



Richard & JoAnne Lawson



John Saunders

*RECENT RELEASES ON BELCO:*

**B-371 LOVELY HULA HANDS/JOHNSON RAG**

*NEW ON CROW:*

**C-002 OKLAHOMA HILLS**, Flip/Inst. by Bill Crowson

**C-001 CALENDAR GIRL**, Flip/Inst. by Bill Crowson



Bill & Virginia Tracy



Bill Crowson

2832 Live Oak Dr., Mesquite TX 75150 1-214-270-0616

### MESQUITE SHIRTS

65% poly/35% cotton \$26.95

COLORS AVAILABLE:

WHITE  
RED  
ROYAL BLUE  
DUSTY ROSE  
BLACK  
YELLOW  
PINK, PEACH  
CREAM, GREY  
KELLY GREEN  
NAVY, LILAC  
BROWN, CORAL, ORCHID

80%poly/20% cotton \$27.95

COLORS AVAILABLE:

WHITE/WHITE  
CREAM/CREAM  
LT. BLUE/LT. BLUE



### RANGER PANTS \$32.95 EACH

BANROLL WAIST SNAP POCKET

100% poly

SIZES AVAILABLE: 28, 29, 30, 31, 32, 33, 34, 35, 36, 37, 38, 40, 42, 44, 46, 48

COLORS AVAILABLE:

BURGUNDY, BONE, WHITE,  
KELLY GREEN, YELLOW,  
TAN, BLACK, TURQUOISE  
RED, CAMEL, GREY,  
ROYAL BROWN, NAVY, LT. GREY  
DUSTY ROSE, POWDER BLUE

65%poly/35% cotton

COLORS AVAILABLE:

WHITE, GREY,  
BLACK, NAVY,  
WHEAT, BROWN



MR. COAST \$44.95

SOFT TOP GRAIN  
LEATHERS, CUSHIONED  
INNERSOLES, CHROME  
SPLIT LEATHER OUTERSOLES

M W

Black 7-12 7 1/2 - 12

White 7-12



VISA & MASTERCARD ACCEPTED

FOREIGN SHIPMENTS PLEASE ADD

\$6.00 PER ITEM, CANADA, HAWAII,

ALASKA RESIDENTS ADD \$3.00 PER ITEM.

SEND WITH ORDER—STYLE, COLOR, SIZE, PRICE, YOUR NAME, ADDRESS, CITY, STATE, ZIP AND TELEPHONE NUMBER. FOR CHARGE PURCHASES, PLEASE SEND CARD NUMBER, NAME PRINTED ON CARD, AND EXPIRATION DATE. PLEASE ADD \$3.50 FOR SHIPPING & HANDLING. MISSOURI CUSTOMERS, PLEASE ADD 6% SALES TAX.



CHEYENNE \$48.95

FULL LEATHER UPPER &  
LINING, SQUARE DANCE &  
CASUAL DRESS FOR MEN,  
STEEL SHANK, CUSHION  
INSOLE, CREPE OUTSOLE  
& HEEL

BLACK, WHITE

BROWN & BONE

M W

7-13 7-13

EXTREMELY

COMFORTABLE

SLEEVE	NECK										
	14 1/2	15	15 1/2	16	16 1/2	17	17 1/2	18	19	20	
32	X	X	X	X							
33	X	X	X	X	X	X	X				
34	X	X	X	X	X	X	X	X			
35	X	X	X	X	X	X	X	X	X		
36	X	X	X	X	X	X	X	X	X	X	X

FOR 1989 CATALOG—SEND \$1.00  
REFUNDED WITH FIRST ORDER

*Western Squares, Intl.*

6820 Gravois

St. Louis, Missouri 63116

(314) 353-7230



## PETTICOAT HANG-UP?

Don't know where to store your petticoats neatly and conveniently. Solve your petticoat problems with an all new

## PETTICOAT TREE

Decorate your room and keep as many as 12 petticoats neat and easy to reach. This spring-tension petticoat tree is satin brass plated with 12 especially designed hooks to make it easy to remove and replace your petticoats. The tree fits snugly between floor and ceiling, and can be easily relocated. It fits ceiling heights 7'10" to 8'3" (special heights on request).

Hangers available @ 95¢ ea. (Gray, Rose, White, Cream)

FOR FURTHER INFORMATION CALL (818) 244-6373

ORDER YOURS  
TODAY

Only  
**\$34.50**

Mail to: R&J SPECIALTIES, Dept. A  
1215 Ruberta Ave., Glendale, CA 91201

Petticoat Tree(s) \$34.50 ea. \$ \_\_\_\_\_  
Hangers (Color \_\_\_\_\_) .95 ea. \$ \_\_\_\_\_

Plus shipping and handling \$3.00

Enclosed is \$ \_\_\_\_\_



Satisfaction  
Guaranteed

Dealer Inquiries  
Welcome

Name \_\_\_\_\_

Address \_\_\_\_\_

City \_\_\_\_\_ State \_\_\_\_\_

Zip \_\_\_\_\_ Phone \_\_\_\_\_





# THE COLLEGES ARE COMING

TRAINING  
FOR CALLERS & CUERS

<p><b>Walt Cole's Three TIMING/ MUSIC/CHOREO SCHOOLS</b> Hannibal, Missouri—May 28-31 Rapid City, SD—July 16-19 Pt. Angeles, WA—Aug. 27-Sep. 1 New &amp; Experienced Callers <i>The basis of calling is timing, the basis of timing is music.</i></p> <p><b>Contact: Walt Cole</b> 944 Chatelain Rd., Ogden UT 84408 801-392-9078</p>	<p><b>McCLOUD DANCE COUNTRY McCLOUD, CALIFORNIA</b> Memorial Wknd, May 27,28,29 Labor Day Wknd, Sept. 1,2,3 <i>STAFF: Bob Van Antwerp</i> Clinic for New &amp; Beginning Callers</p> <p><b>For information, write:</b> Dave Abbott, PO Box 1720 McCloud CA 96057 916-964-2252</p>	<p><b>CALLERS COLLEGE at English Mountain Sevierville, Tennessee</b> May 8-11, 1989 <i>Wade Driver, Gary Shoemaker</i> For experienced callers with emphasis on aspects of touring and traveling <b>English Mountain S/D Retreat</b> Rt. 6 Box 212, Sevierville TN 37862 615-453-0171</p>
<p><b>WISCONSIN R/D LEADERS CUERS COLLEGE</b> Holidome, Stevens Pt., WI July 14-16, 1989 7 PM Friday-1:30 PM Sunday Phase I &amp; II Staff: 8 Active Cuer Couples Deadline: April 15, 1989 <b>Contact: Milt &amp; Alice Spoor</b> 13325 Burleigh Rd. Brookfield WI 53005 414-782-7582</p>	<p><b>MIDWEST CALLERS COLLEGE</b> Promenade Hall Auburn, Indiana for new/newer callers June 11-16, 1989 (Just before Nat'l Convention) <i>Stan Burdick, Don Taylor</i></p> <p><b>Don Taylor, Promenade Hall</b> 112 Depot St, Auburn IN 46706 219-925-3818 or 925-6039</p>	<p><b>NORTHERN N.Y. CALLERS COLLEGE</b> Silver Bay, N.Y. July 19-23, 1989 <i>Stan Burdick &amp; guests</i> For 1-5 year callers only Complete Course Fundamentals <b>Write Stan Burdick</b> P.O. Box 488 Huron OH 44839</p>
<p><b>TURKEY RUN R/D LEADERS SCHOOL</b> Turkey Run State Park Marshall, Indiana July 16-21, 1989 Phases 4-5-6 <i>Staff: Irv &amp; Betty Easterday</i> July 23-28, 1989 Phases 1-2-3 July 28-30, 1989 Phases 3-4 <i>Staff: Betty &amp; Clancy Mueller</i> <b>Write Betty &amp; Clancy Mueller</b> 1112 Hollybrook Dr. New Whiteland IN 46184</p>	<p><b>HOLIDAY OF HARTLAND Hartland, Michigan</b> July 16-19, 1989—<i>Al Brundage, Earl Johnston, Dick Bayer</i> <b>CHARLOTTESVILLE, VIRGINIA</b> St. Anne's-Belfield School July 23-26, 1989 <i>Al, Earl &amp; Tom Miller</i> <b>NEW ENGLAND SCHOOL</b> August 13-17, Sturbridge, Mass. NEW &amp; EXPERIENCED CALLERS <i>Al Brundage — Earl Johnston</i> Earl Johnston, PO Box 2223 Vernon CT 06066</p>	<p><b>ED FOOTE CALLER'S SCHOOL</b> Pittsburgh, Pennsylvania July 9-13, 1989 Emphasis on Choreography, Sight Calling, Stage Presence, Programming, Voice, Work- shopping, Dance Program Limit 8 for max. personal attention, 6 mos. experience <b>Write Ed Foote, 140 McCand- less Dr. Wexford PA 15090</b></p>
<p><b>2nd ANNUAL KACHINA KOLLEGE FOR R/D TEACHERS</b> Parrish Ranch Campground Berthoud, Colorado May 21-25—Beginning Teacher May 28-June 1—2-5 Yrs. Exp. June 4-8—5+ Yrs. Experience Emphasis on Teaching, Cueing &amp; Dancing Techniques</p> <p><i>STAFF: Ray &amp; Anne Brown</i> <b>INFO: Ray &amp; Anne Brown</b> 10975 E. Berry Av., Englewood CO 80111 602-984-1780</p>	<p><b>LASRY COLLEGE FOR CALLERS</b> English Mountain Resort Sevierville, Tennessee July 30-Aug. 1, 1989 <i>Jack Lasry—Earl Johnston</i> Limited to 20 callers: 10 Experienced, 10 Newer</p> <p><b>Write: Jack Lasry</b> 1513 No. 46 Ave. Hollywood FL 33021 305-981-7788</p>	<p><b>DANCE O RAMA COLLEGE (Since 1965)</b> August 18-19-20, 1989 <i>Complete Curriculum Lodging &amp; Meals Included</i> New &amp; Experienced Callers Individual Attention</p> <p><b>Write for Information to:</b> Harold Bausch, 2120 Jaynes Fremont NE 68025 402-721-4925</p>

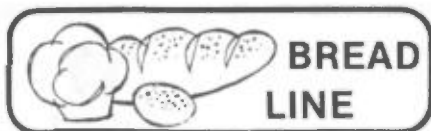

by **Bev Warner**

Whenever anyone asks me what my favorite pie is, I say, "I have two favorites—hot and cold." I was raised in the country with thrashers, and there was always pie for dessert.

We have many farming community S/D clubs who have pie night on their calendars traditionally. One club advertised a Walt Gardner Pie Night (Outsiders thought it was a guest caller). They were surprised to find out Walt was a favorite dancer who loved pumpkin pie, so they honored him with his special night.

At these pie nights, tables are laden with pies—pumpkin, pecan, apple, every berry imaginable, even wild black- and blueberries. Then come the cream pies with mountain-high meringues and whipped cream toppings, mock

apple and walnut—impossible pies you would swear were made with real apples, nuts and coconut. Diabetic pies even hit the spot with health-conscious dancers. There is always a favorite of mine—hot or cold.

A pie survey taken in the state of Michigan named favorite pies in this order: 1. Lemon meringue; 2. Pecan; 3. Apple. I wonder how people in your state would list their favorites.

Here is that famous favorite recipe:

- 1 can (16 oz.) Libby's solid pack pumpkin
  - 2 eggs, slightly beaten
  - $\frac{3}{4}$  cup sugar
  - $\frac{1}{2}$  tsp salt, 1 tsp ground cinnamon,  $\frac{1}{2}$  tsp ground ginger,  $\frac{1}{4}$  tsp ground cloves
  - 1 can (12-13 fl. oz.) Carnation evaporated milk
- Preheat oven to 425. Mix filling ingredients in order given. Pour into pie shell. Bake 15 minutes. Reduce heat to 350°; continue baking 45 minutes or until knife inserted near center comes out clean. Cool completely. Garnish, if desired, with whipped topping. Yields one 9-in. pie.

**NORTH TEXAS CALLERS COLLEGE, Friendship Hall, Rockwall, Texas (East of Dallas)**

(Just 4 hours from the National Convention)

For 0-3 Year Callers

June 11-16 □ July 17-21 □ August 14-18      STAFF: T.D. Brown & Guests

● CHOREO MANAGEMENT ● SIGHT VS. MODULES ● MENTAL IMAGE ● MEMORY ●

WRITE: T.D. Brown, PO Box 940, Rockwall TX 75087 or Call 214-771-9701

**SUPER SCHOOL-WEST**  
Bally's Hotel, Reno, Nevada  
August 13-18, 1989

*Herb Egender, Bill Peters  
John Kaltenthaler, Jim Mayo*

*Full Curriculum Tailored  
To Individual Needs*

Write: Bill Peters  
PO Box 10692

Zephyr Cove, Nevada 89448

**NORTHWEST CALLER COLLEGE**  
at the beautiful Square &  
Round Dance Center, and  
Campground, Lolo, Montana  
July 19-21, 1989

*Daryl Clendenin, Chinook  
Records Recording Artist*

Limited: 12 callers  
Make the College A Part  
of a S/D Vacation.

Write: 9955 Hwy 12  
Lolo MT 59847

**CALLERS COLLEGE**  
Parrish Ranch  
Berthoud, Colorado  
June 11-17, 1989

*Jack Murtha  
Vaughn Parrish*  
For all levels

Teaching & Choreography  
Call Jack Murtha: 916-673-1120  
Vaughn Parrish in Arizona (W):  
602-982-1088  
Parrish Ranch (S): 303-772-5118

**CALLERS COLLEGE**  
Showboat Hotel  
Las Vegas, Nevada  
Aug. 13-18, 1989  
*Bill Davis, Kip Garvey*  
Sight Calling, Formation  
Awareness, Lots of Mike Time

Contact: Bill Davis  
1359 Belleville  
Sunnyvale CA 94087

**JEKYLL CALLER'S COLLEGE**  
Jekyll Island, Georgia  
July 16-20, 1989  
*Dick Barker & Guests*  
Teaching Techniques, Workshop-  
ping, Programming, Emphasis  
on Choreography, Individual  
Attention, Mike Time  
New/Newer callers—Limit 20

Write Dick Barker  
2408 Eastover Drive  
Waycross GA 31501

**SOUTHERN CALLERS SCHOOL**  
Grand Hotel, Pigeon Forge, TN  
(Scenic Gallinburg Area)  
July 2-6, 1989

*Staff: Don Williamson, Stan  
Burdick. Assoc.: Johnny Jones,  
Stan Williamson*  
For new/newer callers  
Tuition: \$175.00 plus lodging  
Full Callerlab curriculum taught.  
Don Williamson, Rt. 8, College  
Hills, Greeneville TN 37743

# FASHIONS

Mail Orders Available from these Shops



## CALIFORNIA

**DORIS'S Crystal Magic Petticoats**  
8331 Pinecrest Drive  
Redwood Valley CA 95470  
Toll free 800-468-6423  
*Free Swatches, Flyers*

**ROMIE'S S/D & WESTERN WEAR**  
3827 El Cajon Blvd.  
San Diego CA 92105  
(619) 280-2150

**CAROL'S COUNTRY CORNER S/D**  
21932 Schoenborn St.  
Canoga Park CA 91304  
818-347-1207  
*Quality at Discount Prices*

**BOOT HILL S/D APPAREL**  
*Discount Prices*  
7610 Balboa Bl.  
Van Nuys CA 91406  
818-901-9544

**THE KIRKISH STORE**  
198 S. Murphy Ave (cor. of Wash.)  
Sunnyvale CA 94086  
408-736-6243  
*Clothing and Western Wear*

## COLORADO

**DIANNE'S**  
9797 W. Colfax Ave  
Colfax-Kipling Shopping Center  
Lakewood, CO 80215  
*Square Dance & Western Apparel*

## FLORIDA

**OXBOW S/D SHOP**  
8650 49th St. N.  
Pinellas Park FL 34666  
813-541-5700  
*Everything the dancer needs*

**PROMENADE SHOP**  
4200 F 62nd Ave. N.  
Pinellas Park FL 34665  
813-522-4547  
*Everything for the Square Dancer*

## GEORGIA

**L'ELEGANTE PRINCESSE**  
PO Box 378  
Helen GA 30545  
404-878-3147  
*One of a kind designer outfits*

## ILLINOIS

**SQUARE DANCE ATTIRE**  
7215 W. Irving Park Road  
Chicago IL 60634  
312-589-9220

**KATHLEEN'S Square Dance Shop**  
508 West Chestnut  
Chatham IL 62629

## INDIANA

**BEV'S SQUARE DANCE & WEST.**  
112 Depot St.  
Auburn IN 46706  
219-925-3818 or 925-6039  
*24-hour Phone Service*

## LOUISIANA

**JANET'S S/D SHOPPE**  
Rt. 9 Box 997 (318)855-4470  
Lake Charles LA 70611  
*Member NASRDS; Visa & MC*

## MAINE

**WHEEL AND DEAL SHOP INC**  
Rt. 115 Yarmouth Rd.  
Gray ME 04039  
207-657-3412  
*Catalog \$1 Refund with 1st Order*

## MARYLAND

**ANDES S/D & WESTERN APPAREL**  
2109 Liberty Rd. (301-795-0808)  
Eldersburg MD 21784  
*Catalogue Available—\$2  
Credited on First Order*

## MICHIGAN

**RUTHAD (313-841-0586)**  
8869 Avis  
Detroit MI 48209  
*Prettier, perkier petticoats &  
pantalettes*

**SKYLINE S/D SHOP**  
9 Skyline Dr. 507-345-1900  
Mankato MN 56001  
*Member of NASRDS  
We welcome mail orders!*

## NEBRASKA

**SQUARE COUNTRY WESTERN**  
UAA Bldg. 13th & High St.  
Lincoln NE 68502 (402)423-3932  
*Largest Selection S/D Apparel in  
the Midwest, with the Best Prices*

## NEW JERSEY

**YELLOW ROCK SHOP INC.**  
233 Lakeview Ave.  
Clifton NJ 07011  
24-hr. Phone Service 201-478-0010  
*Crinolines \$39.95—Any 4 Colors*

## NEW MEXICO

**JEANETTE'S ORIGINALS**  
4017 Central Ave. NE  
Albuquerque NM 87108  
505-255-8961

## NEW YORK

**ROCHESTER SHOE STORE**  
8186 Pembroke Dr.  
Manlius, NY 13104  
*Discount Prices  
Send for free catalog*

**SKY RANCH WEST. & S/D STORE**  
109-111 S. Main St. (315-668-2644)  
Central Square NY 13036  
*Complete Western & S/D Store  
Send for Free Catalog*

## NORTH CAROLINA

**CIRCLE W S/D FASHIONS**  
Don & Jackie Wilkins  
Rt. 1 Box 313 (Phone 919-327-3337)  
Sneads Ferry NC 28460  
*Mail Services—MasterCard-VISA*

## OHIO

**M & H WESTERN FASHIONS**  
13002 Lorain Ave (216-671-5165)  
Cleveland OH 44111  
*Dancer's Shopping Delight*

## TRIANGLE WESTERN

Columbus OH 43207 (614-491-8151)  
*Complete shop on wheels*

# P U Z Z L E P A G E

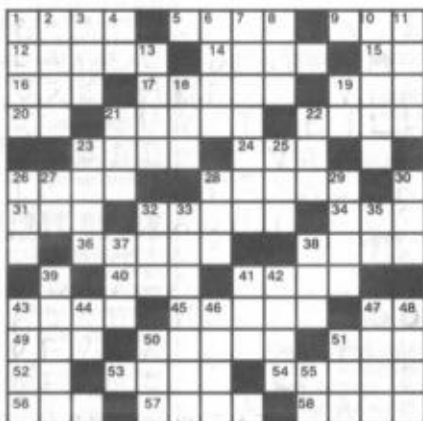

**SQUARE TOGS**  
11757 US 42  
Sharonville OH 45241  
(513) 769-4863  
*Records Available Too!*

**OKLAHOMA**  
LOWELL'S PLACE on Main  
119 West Main  
Moore OK 73160-5105  
Apparel 405-799-5602  
*Just outside OK City & worth the trip!*

**PENNSYLVANIA**  
FABIAN'S WESTERN WEAR  
*Square Dance Apparel*  
18th & Jefferson Sts.  
Lewisburg PA 17837  
Phone: 1-717-523-6280

**TEXAS**  
THE CATCHALL  
1813 Ninth  
Wichita Falls TX 76301  
*Square & Round Dance Regalia*  
*Immediate Mail Order Service*

N BAR J (MARJAC)  
2406 S. Hampton Rd.  
Dallas TX 75224  
214-339-2251

YELLOW ROCK SHOP  
1604 S. Buckner Blvd.  
Dallas TX 75217  
*Free Catalog*

**VIRGINIA**  
LIW WESTERN APPAREL  
Rt. 4 Box 19  
Elkton VA 22827  
Phone: 703-298-8676

PETTICOAT CORNER  
S/D Fashion Coordinates  
Parham Plz. Mall, 1540 Parham Rd.  
Richmond Virginia 23229  
Phone: 804-270-4847

TRIPLE R WESTERN WEAR  
KMB ENTERPRISES, INC.  
250 W Broad St.  
Falls Church VA 22046

**CANADA**  
S/DANCERS FASHION EXCHANGE  
3282 East 1st Avenue  
Vancouver BC V5M 1B8  
Phone: 251-5530  
*Ken & Sally Crisp, Caller/Teachers*

## ACROSS

1. Unit of musical rhythm
2. Rhythmic hand action
9. Initials of favorite magazine
12. Identifying brand of records
14. Precious stone
15. Yours truly
16. Worth
17. Popular Phases V & VI dance
19. By way of
20. In the matter of
21. First through snack line
22. Heyman, caller for nationwide audience at Liberty Festival
23. One of parties in contest
24. Inherited antigen
26. Solution to petticoat storage
27. State of S/D capital of the world
31. Industrious insect
32. Ken Jeffries' Blue Star release
34. Grab more than one's share
36. Marshall Filippo's Chaparral release
38. Alexander, worldly mother in the movie, *Square Dance*
40. In the manner of
41. The cat's ----
43. Dance on '88-89 Roundalab classics
45. Moves back of foot rhythmically
47. Perform
49. Flying saucer
50. Country dance
51. One of three F's of S/D vacations
52. No funds (Abbr.)
53. His name means *champion*
54. Master of ceremonies
56. S/D setting
57. City in Siberia
58. Talk impudently to

## DOWN

1. Fuzzy view of fast dancers
2. Comfort
3. His full name means "father of many"
4. Tellurium (chem.)
6. Girl's name
7. Perpendicular from center of regular polygon to any side
8. Series of steps in dancing
10. Drew Searce recording
11. Bargain
13. Praise highly
18. River in Scotland
19. Roman 6
21. Scottish "give"
22. Sheep talk
23. Groups of S/D couples
25. Roman 61
26. Means of identification
27. One licensed to care for sick
28. Tap with foot
29. Foundation celebrating silver anniversary in 1989
30. Not a barrier to dance fun
32. Nothing
33. Site of National S/D Convention
35. To proceed as scheduled
37. Exclamation of surprise
38. Saltel, singer on Chinook (abbr.)
39. Highly rated Roundalab classic
41. Honey in pure, clarified form
42. In addition
43. Suspended
44. In precisely this manner
46. Snake-like fish (pl.)
47. Club member's financial obligation
48. Change for a five
50. Oldtime luxury car
51. Farm Credit Administration (Abbr.)
55. Miss or Mrs.

by John K. Young  
Braintree, Mass.

## RECORD DEALERS

MAIL ORDER—MASTER RECORD SERVICE  
PO Box 37676

Phoenix AZ 85069 (602-997-5355)  
Square, round, ballroom, pop labels  
Specializing in mail & phone orders

SPECIALTY RECORDS & SUPPLIES

PO Box 335  
Largo FL 34649  
(813)535-3043

All Labels, amplifiers, needles, etc.

PALOMINO S/D SERVICE

Fair 'N Square Records Division  
S25 W26319 MacArthur Rd.  
Waukesha WI 53188 (1-800-328-3800)

SUPREME AUDIO/HANHURST'S TAPE SERVICE

PO Box 687, Ridgewood NJ 07451-0687  
Toll Free: 1-800-445-7398; in N.J.: (201)445-7398  
THE Professional Source for Square and Round  
Dance Records & Equipment—FREE CATALOG

PROMENADE SHOP

11909 N.E. Halsey, Portland OR 97220  
503-252-7623

New Record Release Tape Service for  
just \$21. Yr & you keep the tapes.

ALLEMANDE SHOP

PO Box 8246, Chattanooga TN 37411  
Call Toll Free 1-800-346-4867

Tape Service available only \$24 per year,  
YOU keep the tape

EDDIE'S & BOBBIE'S RECORDS

Box 17668 — 1835 S. Buckner  
Dallas TX 75217-0668 (214-398-7508)

CANADA

THOMASSON S/D SPECIALTIES

121 Barrington Ave.  
Winnipeg, Manitoba R2M 2A8

OVERSEAS

HOWARD MARKS, 1 Ivy Road  
London E17, England (Ph.01-539-7967)  
Serving the movement since 1954  
Mail Order A Specialty. Member NASRDS

SONG AND DANCE STORE

The Market Hall, Alexandra Rd.  
Clevedon, Avon, England Tel. (0272)343844  
Suppliers of Records, Tapes  
Caller Equipment & Dancewear

## BADGES

CENTURY CLUB

Merit Badge of Distinction. Join today.  
PO Box 57  
Westfield MA 01086  
Cost: \$2.00 plus 50¢ postage & handling.

PAULY'S (715-845-3979)

PO Box 72  
Wausau WI 54402  
Engraved and Jeweled Badges

H & R BADGE & STAMP CO (614-471-3735)

Engraved Badges & Rubber Stamps  
From our Design or Yours  
Harold & Roberta Mercer  
2585 Mock Rd., Columbus OH 43219

KA-MO ENGRAVERS

PO Box 30326  
Albuquerque NM 87190  
3D Club & Fun Badges  
Free Catalogue—Ph.505-883-4963

90

D & H ENGRAVING

N 5003 HWY Q (1-608-847-6569)  
Mauston, WI 53948  
Club, Fun & Mini Badges  
Send 25¢ for Catalog

Computerized Engraving by LOWELL'S PLACE  
119 West Main.

Moore, OK 73160-5105 (405-794-5774)  
Just outside OK City  
& Worth the trip!

## NOTES FOR CALLERS

NEWS 'N NOTES

Ed Foote  
2107 Shunk Ave  
Alliance OH 44601

THE NEW VIEW

Bill Davis  
1359 Belleville  
Sunnyvale CA 94087

LEAD RIGHT CALLERS NOTES

Don Malcom—Stan Burdick  
Maverick Enterprises, RR 2 Box 20  
Sheldon Mo 64784, \$22.00 Yearly

SOUTHERN CALIFORNIA CALLERS ASSN. INC.

Callers Notes Service  
4819 West M-12  
Quartz Hill CA 93536-2429  
805-943-6984

CHOREO BREAKDOWN

Don Beck (508) 897-9767  
176 West Acton Rd.  
Stow MA 01775  
Send for FREE sample.

MINNESOTA CALLERS NOTES

Warren Berquam  
3775 County Road 92 No.  
Maple Plain MN 55359  
Mainstream through A-2

DANCE TIME NOTES FOR CALLERS

Dick Han 219-583-5902  
513 South Bluff St.  
Monticello IN 47960  
Write for Free Sample

CANADIAN CALLERS NOTES

Anne & Joe Uebelacker  
RR1 1158 Tara Rd.  
Peterborough, Ontario K9J 6X2  
Basic thru Plus or Adv. thru C-3

## SQUARE DANCE HALLS

In the St. Petersburg area:

**OXBOW HALL, INC.**  
8451 49th St. No.  
Pinellas Park, Florida 33565  
Earl Steele, Owner, 813-821-3809

## TAPES

**AUDIO TEACH & DANCE TAPES BY ED FOOTE.** MS & Plus taught all-position to dancers who already know the calls from standard position. A-1 and A-2 taught with walkthru & practice of all calls. Teach tapes emphasize *understanding* of calls, are widely acclaimed as best on the market. Drill tapes, dance tapes & two-couple tape also available. Write for literature to: Ed Foote, 140 McCandless Pl., Wexford PA 15090.

**VIDEO ALL POSITION TEACH TAPES BY ED FOOTE.** Calls are taught all position for dancers who already know the calls from standard position. Numerous walkthrus of the more difficult calls at each Callerlab program, along with brief samples of dancing, and hints for successful dancing. *Understanding*



of calls is emphasized. 4 video tapes available: Mainstream, Plus, A-1, A-2, each tape about 90 minutes long, VHS format. Cost: \$39.95-1 tape; \$59.95-2 tapes. Order from Dale Garlock, 2107 Shunk Ave., Alliance OH 44601.

## BOOKS

**STEP-CLOSE-STEP ROUND DANCE BASICS.** 1986 Edition, Round Dance Basics Book, \$8.00 ppd. Now includes 10-week dancer-proven course, dance positions, complete approved terminology, mixers, teaching hints, plus introduction into foxtrot, tango, cha cha and ballroom. Coordinate with the Grenn record teaching series. Order book and/or records from Frank Lehnert, 2844, S. 109th St., Toledo OH 43611.

**THE TWO POCKET DICTIONARIES OF SQUARE DANCE CALLS**—Book 1, Mainstream; Book 2, Plus program and A1 & A2. To order: Send \$3.50 to Pocket Dictionary, PO Box 2223, Vernon CT 06066. Specify which book you are ordering.

**SIGHT CALLING SIMPLIFIED**—An easy and simple system for new sight callers. Based on the premise that anyone can sight call. Price \$6.50. Order from Whitey Aamot, 916 3rd Ave. SE, Waseca MN 56093.

**COLD FEET: How To Get Them Dancing** by Kaye Anderson. 150-page Round Dance reference book for the Beginning Dancer. Step-by-step directions for man and woman. 140 diagrams; 430-item index. \$11.50 ppd. DANCE ACTION, PO Box 127, Jackson MO 63755.

**COUNTRY WESTERN DANCING.** Book 1. Line dances, Round & couple dances. Book II, Continues on! Book III, Photographed Turns! Book IV, Teacher's Manual. Book V, Line Dances Galore. Order by number. \$20 includes pstg. & handling. Kelly Gellelte, PO Box 43425, Las Vegas NV 89116.

**OUT OF SIGHT. A Text on Mental Image Choreography for Square Dance Callers.** Learn what makes choreography "tick" with this step by step approach to mental image and sight calling. Send \$20. plus postage (\$1.00 or overseas \$6.00) to Don Beck, 176 W. Acton Rd., Stow MA 01775. 508-897-9767

**THE CALL'S THE THING**—A new booklet that just might be the "survival kit" for square dance clubs experiencing financial or other difficulties that threaten to force them out of existence. It features a CALL CARD designed for beginners as well as veteran dancers to properly describe the execution of calls as well as a CALL CARD RACK for flexibly displaying the cards for reference at classes or dances. Many other features include: TEACHING TAPES—THE SQUARE DANCE POSITION GAME—"COMPUTER" SLIPS FOR FORMING SQUARES BY NUMBERS—DIAGRAMMING DECALS—LINE DANCE INSTRUCTIONAL TAPES—AND MORE. \$4.00 plus \$1.00 post. & hand. Satisfaction guaranteed. Russell L. Hoekstra, 67 Forest Glen, Rm 321, Longmeadow MA 01106

**POTLUCKS AND PETTICOATS.** 336 pages of square dancers' favorite recipes AND a full color history of American square dancing. Club fund raisers—Christmas presents—everyday use! \$11.95 plus \$1.50 shipping. Quantity discounts. Potlucks and Petticoats, PO Box 129, Dillard GA 30537. Credit card orders 404-746-2134.

**SQUARE DANCING ENCYCLOPEDIA:** \$15.00; All Movements. **MINI-BOOK,** Basics-C3, \$7.00. **DIAGRAMMED GUIDE**—Basics & Plus, \$7.00. **ADVANCED DIAGRAMS:** Plus-C2, \$10.00. Order from Jon Sanborn, 661 Middlefield Rd., Salinas CA 93906. Phone: 408-443-0761.

## DISTRIBUTORS

ASTECC RECORD DIST., PO Box 687  
Ridgewood NJ 07451-0687, Toll free 1-800-445-7398

MERRBACH RECORD SERVICE, PO Box 7309  
HOUSTON TX 77248-7309, 713-862-7077

SUNDANCE DISTRIBUTORS, 9356 Natick Ave.  
Sepulveda CA 91343, 818-894-5621

TWELGRENN ENTERPRISES, PO Box 216  
Bath OH 44210, Member NASRDS

## S/D PRODUCTS

**SQUARE DANCE SEALS**—Five color, eye-catching SEALS on all correspondence, checks, etc., are an invitation to square dancing. Order from Box 18/442, Memphis TN 38181. 3 sheets (50 each), \$1+ .25 p&h; 10 sheets, \$3+.75 p&h; 20 sheets, \$5.00 +\$1 p&h; 100 sheets, \$17.50 + \$2.50 p&h. (1st class). Samples on request.

**YAK STACK**—Sound Columns for Callers

Write PO. Box 2223, Vernon CT 06066  
Phone 203-649-5144

YAKETS (Plastic Record Covers)

\$9.00 Per 100 plus \$3.50 shipping

**SQUARE DANCE/ROUND DANCE THEME COUNTED CROSS-STITCH PATTERNS.** 3 square books, 1 round book, 5 patterns each. \$5.00 ea. +\$1.50 pstg. per order. State patterns available upon request at \$1.50 ea. +50¢ pstg. per order. Dealers welcome. Ralph & Mary Ann Kornegay, 138 Mohican Trail, Wilmington NC 28403.

**NASHVILLE SOUND PLUS YOU CASSETTES.** Back-up music to the greatest country hits. YOU are the solo artist. Great for after-parties, between tips, etc. Complete list free upon request. Yellow Rock Shoppe, 1604 S. Buckner Blvd., Dallas TX 75217. Tel: 214-391-7040.

FREE! SAMPLE TAPE

**HANHURST'S TAPE & RECORD SERVICE**

MONTHLY TAPE Contains All New S/D Music

TOLL FREE Order Phone — DISCOUNTS

Serving Callers Since 1972 — A Perfect Gift for Your Caller

Call TOLL FREE 1-800-445-7398

Bill & Peggy Heyman, PO Box 687

Ridgewood NJ 07451-0687 (In NJ, 201-445-7398)

**LIGHTWEIGHT ALUMINUM SPEAKER STANDS.** Only 9 lbs., fold to 32", extend to 86". Best Built, Best Price \$75.00 plus shipping. Halpo Industries, 775 Youn-kin, Columbus OH 43207 (614-491-8151).

HILTON AUDIO PRODUCTS, INC.

amplifiers • speakers • microphones  
wireless microphones • speaker stands

1033-E Shary Circle, Concord CA 94518

Telephone: 415-862-8390

**NEEDLEPOINT Matching TIE SLIDES and TOWEL HOLDERS** on plastic canvas to color coordinate with all of your outfits. For complete instruction sheet, send \$1.75 to Candy's Crafts, RD 2 Box 178, Susquehanna PA 18847.

## FOR SALE

**SQUARE DANCE HALL,** 2 wood floors, Rocky Mt. location, large living quarters, ten activities weekly. Excellent Opportunity. Write American Squaredance Magazine, Dept. A, Box 488, Huron OH 44839.

**EQUIPMENT:** 1 Newcomb Variable Speed Amp. Model TR1656-60W; 2 48"-column speakers and stands; 2 cases records (Approx. 200); Mike; All like new. Covers for all equipment except stands and record cases. Write PO. Box 605, Eaton OH 45320 or call 1-513-456-2917.

**MUST SELL**—Entire Inventory of Square Dance Apparel. For more information, contact August or Norma Deibert, 1506 Bill Nye, Laramie WY 82070. (307) 742-4577 Evenings & Weekends.

## ASSOCIATIONS

NATIONAL S/D CAMPERS ASSOCIATION  
Dept. B, PO Box 224, Little Chute WI 54140

MORE ON NEXT PAGE

SQUARE DANCERS OF AMERICAN MENSEA, LTD.  
Bruce W. Franz, 460 Lamplighter Place  
Xenia OH 45385 (513)372-0448

## RESORTS/CAMPGROUNDS

**NOBODY TREATS DANCERS BETTER THAN COPECREST**  
Vacation in the mountains with a week of dancing at Copecrest.  
We offer superb food, modern air-conditioned rooms, swimming pool and a staff that pampers you! Write Copecrest S/D Resort, PO Box 129 Dillard GA 30537, or call 404-746-2134

**WESTERN MONTANA Square & Round Dance Vacation.**  
June 8-Sept. 3. 11 miles south of Missoula. Dancing every evening. National callers on weekends. No Packages. Campground among the pines on Lolo Creek. Square & Round Dance Center, 9955 Highway 12, Lolo MT 59847. 406-273-0141.

## FESTIVALS

**TEXAS TEACHER TRAINING INSTITUTE** for round dance leaders. Emphasis on Phases III & IV. Staff: Bob & Mary Ann Rother, Don & Pete Hickman, and John & Norma Becker. July 23 - 28, 1989. Contact: Don & Pete Hickman, 12118 Los Cerdos, San Antonio TX 78233. Phone (512) 656-5268.

## CALLERS' COLLEGE

**DANCE RANCH CALLERS' COLLEGE**, July 30-Aug. 3, 2 Years or Less Experience; Aug.6-10, 2 years or more experience. Write Frank Lane, PO Box 1382, Estes Park CO 80517.

## CALLER WANTED

**COMING TO JAPAN?** The Skoshi Squares need a caller for Mainstream Level dancing and classes beginning in May/June 1989. If interested, write Frances Wyland, PO Box 823 Futenma, FPO Seattle WA 98772.



# 1989 EDITION



The  
**NATIONAL SQUARE DANCE DIRECTORY**  
is published in January each year.

- Information and contacts for over 10,000 clubs around the world. Great for traveling.
- Advertisements for over 1000 square dance related products & services.
- Directories of festivals, conventions, callers & leaders.
- Square dance sewing & crafts section.

Available at most square dance shops or order direct:

\$7.00 (plus \$2.00 postage)  
\$40.00—Life Subscription

**NATIONAL SQUARE DANCE DIRECTORY**  
PO Box 54055, Jackson MS 39288  
Phone: 601-825-6831

## We're Breaking Records...



Yes, we're probably **NUMBER ONE** anywhere  
for fast service on your order of records!

- **SQUARE**
- **ROUND**
- **FOLK**
- **CLOGGING**
- **SOLO DANCE**

**NEW OWNERS:** Lyle & Faye Long  
S25 W26319 MacArthur Rd.  
Waukesha WI 53188  
(414) 542-9684

### CHECK THESE FEATURES:

- 20,000 INVENTORY**  
—for the latest and the "hard to get" choices!
- FULL-TIME EVERY DAY SHIPPING**  
— minimum of waiting, we ship daily!
- NEW, FREE WATS LINE**  
—for orders, dial 1-800-328-3800!

## PALOMINO SQUARE DANCE SERVICE

Outside Wis. 1-800-328-3800

## SQUARE DANCERS MASTERCARD

The United Square Dancers of America (USDA) recently announced a nationwide credit card program for dancers. Any dancer in the square dance activity (square, round, clogging, contra, line, or heritage) can apply for the card—the only credit card that identifies you as a square dancer everywhere you go.

The Square Dancers MasterCard grew from an idea first put forth at the USDA annual meeting at the 1987 National Convention in Houston. The Board of Directors of USDA, which is comprised of delegates from the State and Association affiliates, approved the concept; and the program was developed and introduced nationwide in January, 1989.

You may ask, why does square dancing need a credit card? The answer is simple. This is the best possible method of bringing our square dance activities to the attention of every person that handles one of our special credit cards. This will keep Square Dancing in front of the public and assist in publicizing and promoting

square dance activities throughout the nation. Also, USDA, your national association, will receive some operating funds from the Signet Bank for each credit card issued and will share these funds with the member state and association affiliates.

USDA, as the national dancer's association, entered into the program to promote square dance activities nationwide and to obtain operating funds to support its many on-going (and future) projects that benefit square dancing, both at local and national levels. USDA is bound by its charter and IRS Regulations to use these funds only to serve the square dance movement.

One-third of all surplus funds for this program will be returned to the affiliates for their use to locally promote square dancing.

For details of the Signet Bank program, an application form and further information on the USDA Silver MasterCard, you may call Signet Bank toll free at (800)368-4868.

## Mustang Recordings

### New Releases

MS 197 YOU'RE THE REASON (I Don't Sleep At Night)  
MS 196 GONNA TAKE A LOT OF RIVERS

Chuck Bryant  
Bob Shiver

### Future Releases

LAST THING ON MY MIND  
I HEAR THE COUNTRY CALLING ME

### Other Releases

MS 195 Because I Love You That's Why  
MS 194 Greenback Dollar  
MS 193 Guess It Never Hurts to Hurt Sometime

Bill Cash  
Bob Shiver  
Chuck Bryant

(Many Others On Request)

Dealers contact: A & S RECORDS  
321 Laurie Lane  
Warner Robins GA 31093  
912-922-7510

CRUISE HAWAII APRIL 1989  
with Chuck & Peggy Bryant  
7 Days and Nights on Ship  
2 Extra Nights on Waikiki

VIDEO TAPES, BASIC THRU C-1. SLOW WALK-THRU EACH FIGURE.  
LEARNING TAPES.....\$29.95 each

For Video/Cruise, Contact: Chuck Bryant  
P.O. Box 735, San Benito TX 78586 512-399-8797

# UNDERLINING

## THE CALLER NOTE SERVICES

**T**he editorship of the **Southern California Callers Notes Service** is now in the hands of the association president, Larry LeDuc. "Timing the Plus" is followed by two round dances, *The Boy Next Door* and *Johnson Rag*; then MS and Plus material; next, how to use *split a quarter*; and a look at the QS *zip to a diamond*. The back page is devoted to Stan (blush) Burdick's clinic for the association (Quartz Hill, Cal.) on the afternoon of April 9.

**M**ainstream Flow, originated by the late Gene Trimmer, carried on by Jim and Shirley Hayes, has now changed hands again, and is published by Rusty and Kay Fennell of San Antonio, Texas. They're off to a good start. Kay has tips for IRS reporting, like this: "When you are preparing to call out of town or beginning a tour, note on the outside of an envelope the date and the starting mileage. This provides a place to keep all the receipts for the trip and helps insure that all the expenses for the trip are recorded and not just those that you find in shirt pockets."

In addition to some good choreo in 14 pages, Rusty gives us this bit of advice:

"One of the greatest thrills for a dancer and caller to experience is the sound of every dancer's feet sliding on the floor, with beat of the music, and a "swish" of sound. If you have heard this, you know exactly what I am speaking about. Encourage yourself and your dancers to step on the beat and enjoy the dance portion of square dancing. The more we'll dance, the fewer we'll lose!"

**B**y checking the index of Dick Han's **Dancetime Notes**, one can see there's good variety and current material. Take a look: Cloverflo—MS Quarterly Call; Cross Run and Cross Fold—MS Emphasis Calls; Openers and Get-Outs, Food For Thought about the use of Extend; Crossfire—Plus Emphasis Call; Track Two, Drop the Anchor—New Experimental Idea, and Singing Calls. Also in his **Advanced Supplement** (blue section), he gives us some useful 3x1 line stuff, and lots more.

**A** whopping 20 pages of **T&D Callers Notes**, edited by Grant Logan, gives us a good slant on Canadian views and

YOU'LL HAVE  
THE TIME OF YOUR LIFE

**KIRKWOOD  
LODGE**

THE FAMOUS AMERICAN PLAN RESORT

LOCATED AT THE WATER'S EDGE

15 GREAT WEEKS  
15 GREAT STAFFS

FOR  
INFORMATION WRITE:  
KIRWOOD LODGE  
Box 37  
Osage Beach, MO  
65065  
314-348-2161

CALLING  
BY  
JACK  
MURTHA

**SQUARE DANCETIME**

\*ALL FINAL  
PRICES ARE SET  
BY DEALERS AND  
MAY VARY.



## NOW AVAILABLE! TEACHER'S STARTER SET

\$25<sup>00</sup> WORTH OF RECORDS FOR \$19<sup>95</sup>\*

**TEACHERS:** The **TEACHER'S STARTER SET** includes five enjoyable records for beginners.

These records are compatible with the teaching record, **FUNDAMENTALS OF SQUARE DANCING,**

Level 1-SIO 6001, by

**BOB RUFF and JACK MURTHA**

IF RECORDS ARE NOT AVAILABLE AT LOCAL DEALERS CONTACT:

JACK MURTHA • P. O. BOX 3055 • YUBA CITY, CA 95992-3055 • (916) 673-1120

issues in the January issue. Five pages on Sound with diagrams are especially good. *Me and My Shadow* is the R/D selection. The Callerlab Quarterlies are well-covered. A new section of Letters is initiated. Key items from Callerlab are included, and there are three (no less) references and quotes from *ASD*.

Each note service we read has a distinct theme, followed faithfully on a monthly basis, and Don Beck's **Choreo Breakdown** is no exception. First he discusses "What's Happening" (sort of a monologue and current news update), and this time the *QS cloverflo* by Bill Davis and the *QS zip to a diamond* by Dick Han are mentioned, plus a correction about *slide the door* vs. *slam the door*. Featured next is *slip out of a diamond*. MS, Plus and A/C material follows, and finally there's the "Notebook Section" (essay style on Sight

Calling).

We heartily agree with Jack Lasry in his **Notes for Callers** when, among other worthwhile ideas and presentations, he says this about as *couples* choreography for the Plus dancer: "It is my opinion that the as *couples* type choreo that is currently on the Advanced Program should be modified so that this gimmicky-type choreo can be used at Mainstream and Plus dances. The choreography, not the concept, is what should make the call adaptable to all programs. At MS, use the as *couples* concept with MS basics, and with Plus groups, use Plus basics, and with Advanced groups, use Advanced basics...

Heads star thru and spread (Boys act as one person, girls act as one person)

As couples do-sa-do to a wave

As couples hinge, as couples scoot back

**YAK  
STACK**

### the YAK STACK Sound Column *Imitated But Never Duplicated!*



Price info:  
**YAK STACK**  
P.O. Box 2223  
Vernon CT 06066  
203-649-5144

- Eliminates sound problems in bad halls.
- The choice of professional cuers and callers
- More sound per pound!!





As couples circulate

Girls as a couple run around the boys  
As couples do center part of load the boat  
Normal wheel and deal, girls pass thru  
Star thru, ferris wheel, square thru 3/4  
Left allemande...

**F**rom "down under," we always enjoy reading through Eric Wendell's **Callerlink**, even though it arrives spasmodically from Australia to Ohio. By coincidence, Eric covers mechanics of (singing call) figure construction as we found in the Uebelackers' notes this time. He also gives us good thoughts on club organization. Then there's plenty of choreo, especially featuring the *l formation*.

**Y**ou'll find some very useful ideas in Anne and Joe Uebelacker's **Canadian Callers Notes**, with page after page of choreo and a separate section of A and C. The January issue very comprehensively covers the QS realm, gives us teaching tips galore (even with basic material), and devotes almost three pages to a hard-to-find analysis, "How to Call Progressive Squares." That's not all. Another interesting study helps you write your own singing calls. Kudos to Anne and Joe.

**I**n his **Choreo Connection**, Ed Fraidenburg gives us a good smattering of patter using the QS *zip to a diamond*. Here's one:

Head ladies chain, heads lead right and  
Circle to a line, dixie style to a wave  
Centers trade, zip to a diamond  
Boys left swing thru, diamond circulate  
Flip the diamond, girls circulate  
Left allemande...

**O**ne item that might be found helpful for all callers in this issue of **Lead Right** by Burdick and Malcom is a page on "The Care and Feeding of Phonograph Needles." That's only the beginning. There's a list of the timing of basics from Callerlab, resolution material, sing-along calls, QS updates, some hard choreo by Randy Dougherty, formation tips from Jack Lasry and other assorted choreography.

## DO YOUR LEGS & FEET GET TIRED DANCING?

**DANCING LEGS** panty hose are made especially for you, The Head Lady!

It's been proven by our satisfied customers that the springy lycra **support** these **DANCING LEGS** panty hose give you, does relieve that leg fatigue that active square dancers know so well.

These panty hose are made with a **cool cotton ventilated sole** and cotton crotch — a medium **support** to strengthen your legs — **sheer to the hip**, for that glamorous look. **Plus** a much needed **reinforced toe!**

These features will give you an unexpected pleasure you haven't experienced before in a panty hose. No other panty hose offers these **four** combined features. They are the ultimate in comfort and wearability. And you'll find the cool cotton ventilated sole will give you a cushioning effect that's delightful.

All these features put together just for you, The Head Lady. Isn't it time you try a pair and see for yourself?

Ask for

**Dancing Legs**  
Panty hose

AT YOUR FAVORITE SQUARE DANCE STORE  
Or Mail in Your Order

Choose **DANCING LEGS** panty hose in  
three beautiful shades of **SUNTAN, BEIGE**  
or our "new shade," **TAUPE**.

### SIZE CHART

P Petite	4'10"-5'2"	90-115 lbs.
M Medium	5'2"-5'5"	115-135 lbs.
T Tall	5'5"-5'8" (or Short Queen)	135-170 lbs.
Q = Queen	5'7"-5'11"	160-200 lbs.

Send \$4.50 for each pair (no shipping chg.)  
PLUS your **SIZE** and **COLOR** choice to:  
**R & J SPECIALTIES, Dept. A, 1215 Ruberta  
Ave., Glendale CA 91201 (818-244-6373)**

**SATISFACTION GUARANTEED  
OR YOUR MONEY BACK!**

# LEE KOPMAN

NOW AVAILABLE:

- ★ VIDEO TEACHING TAPES (Advanced, C-1 & C-2 levels)
  - ★ INSTRUCTIONAL TAPES on Reel or Cassette  
For Beginner, Mainstream, Plus, Advanced, C-1, C-2, C-3 and C-3A
  - ★ Minus a couple to make up a square?  
Try our (5) Two Couple Tapes geared to Approved Callerlab level lists  
Mainstream — Advanced Level —  
C-1 Level — C-2 Level — C-3 Level
  - ★ DANCE TAPES  
For Mainstream, Advanced (A-2), C-1, C-2, C-3, C-3A & C-4
- For Details, Write to LEE KOPMAN, 2965 Campbell Ave., Wantagh NY 11793



## ENCORE, Continued

meet in clubs and associations. To come out of the seventies with strong clubs, effective associations, and a square dance activity that thrives and flourishes will take the combined efforts of many dancers—those working in LEGACY, Callerlab, state organizations and local clubs. Every last dancer must do a bit toward making square dancing a better activity in which more folks will find fun, fellowship, excitement, novelty, growth, comfort, recreation and whatever the special needs of the eighties may be.

From the "Co-Editorial"

This month from the vacation advertisers, you can enjoy...great fun at Round-A-Rama, LeHigh Resort, Florida, with the Easterdays and Lovelaces, and square dance with Bob Fisk, Lee Kopman...;

piscatorial pleasure at Andy's Trout Farm S/D Resort, Dillard, Ga;...fun in the sun at Myrtle Beach, S.C. and dance to Bob Ferrell, Gene Hawkins; ... dance as well as swim, fish and ride at Parrish Ranch, Berthoud, Colorado.

Penn Yan Friendship Squares combine class and a club workshop in one evening. The class starts at 7 PM, at about 9, the club workshop starts and continues till about ten or later.

The point is that after about half the class season has passed, the caller asks the class to stay and dance for awhile with the club. When the class graduates, they already know most of the club members so the feeling of joining a whole new group does not exist.

New Idea: *Disco swing* by Ron Schneider.



Jimmy Roberson



Bob Price

PRODUCED BY  
JIMMY ROBERSON



LIGHTNING RECORDS  
P.O. Box 748, Oxford NC 27565  
919-693-4852



Barry Echols



Max Arnold

### NEW RELEASES

- LR-104 BUTTON OFF MY SHIRT by Jimmy
- LR-901 I LOVE A RAINY NIGHT by Tony Oxendine
- LR-301 SEA CRUISE by Bob
- LR-401 HOOKED ON Music by Max

### BEST SELLERS

- LR-101 I'LL BE THE ONE by Jimmy
- LR-201 WHAT A WONDERFUL WORLD by Barry
- LR-102 IT'S ONLY MAKE BELIEVE by Jimmy

### BRAND NEW RELEASES

- LR-402 BE-BOP-A-LULA by Max
- LR-105 DO THE LOCOMOTION  
by Jimmy
- LR-103 HELLO TROUBLE by Jimmy
- LR-302 I DON'T THINK SHE'S IN  
LOVE ANY MORE by Bob
- LR-202 EARLY IN THE MORNING  
AND LATE AT NIGHT by Barry

## THOUGHTS ON DANCING FOR SPECTATORS by Bill Barr

I have just returned from Hunter Mt.'s Country Music Festival Part II (New York), and though Nancy and I are both tired, we feel that it was worth going to, and I have some observations to make. Working with the founder of square dancing at Hunter Mountain, Bill Losee, Bill Anderson and I began calling at ten in the morning (The Three Bills, I suppose you could call us.) and had squares going all day when the main show in the big tent didn't interfere. Thousands of people saw and hundreds participated in the proceedings, which involved not only the three days of the Part II weekend, but also the four days of Part I in July. Therefore tens of thousands observed and thousands must have participated. 14 callers were hired and a special tent set up for us.

Observation #1: Almost anyone will attest to a certain reluctance at first on the part of spectators to join in an activity, no matter what it is. The only way to overcome this is to show enthusiasm, either on the mike as a caller, or as a dancer by going into the crowd and gently dragging supposedly unwilling "volunteers" into a square. Here is where a little humor can

go a long way.

Observation #2: You must have dancers there, whether dressed [in square dance attire] or not, to help with the dancing and to sign up potential class-takers.

Observation #3: For a program like this to succeed, followup is essential. *Get the names and phone numbers* should be the battle cry. We often speak of "recruiting" dancers, and I always wince a little when I hear this, because I recall being drafted into the Army, and the term makes the whole situation seem like involuntary servitude. "Promotion is perhaps a gentler and more acceptable terminology for our form of recreation. Which brings up the fourth and final point to be remembered.

#4: Ours is one of the few forms of leisure-time activity which cannot be done alone, is non-competitive by its very nature and can be done by virtually anyone, whether mentally or physically challenged or not, of any age beyond infancy, with an amazing coherence that transcends national boundaries and cultures to a degree that is unrecognized by most people who are not themselves square dancers. Happy dancing!



**PATTERN #275 \$5.50**

### SQUARE DANCE DRESS PATTERNS

Create an original square dance dress for yourself or your club at a fraction of the ready-to-wear prices. Easy to make, extra-full, eight gore skirt with three neckline choices and matching scarf. Patterns in multi-sizes (5-7-9, 6-8-10, 12-14-16, 18-20-40).

Dealer inquiries welcome.

Mail to: AUTHENTIC PATTERNS, INC.  
P.O. Box 170119  
Arlington, Texas 76003

Pattern #275 @ \$5.50 ea. Size(s) \_\_\_\_\_

TOTAL AMOUNT ENCLOSED \$ \_\_\_\_\_

Name \_\_\_\_\_

Address \_\_\_\_\_

City \_\_\_\_\_ State \_\_\_\_\_ Zip \_\_\_\_\_

Add for	1 Pattern —\$1.60	3 Patterns—\$2.90
postage & handling:	2 Patterns—\$2.35	4 Patterns—\$3.25





Red River  
Community House

# SUMMER 1989

## Red River Community House

### 15th ANNUAL TRAIL-END FESTIVAL

June 15-16-17, 1989 Plus Level Dancing

The Community House, a non-profit organization, is probably the most unique and successful project of any recreational area of the United States. Located in Red River, New Mexico, just a few miles from the four neighboring states, Colorado, Kansas, Oklahoma and Texas, it provides a program designed specifically for the entire family all summer, from May 26 through September 23, 1989.



Jerry and Sherry Haag  
Cheyenne, Wyoming



Bill and Marsha Buck  
Shreveport, Louisiana



Toots Richardson  
Res. Caller/Director

For more information, contact:  
**TOOTS RICHARDSON**

WINTER  
1710 Neptune Dr.  
Clinton OK 73601  
405-323-5888

SUMMER  
P.O. Box 213  
Red River NM 87558  
505-754-2349



Daryl Clendinin



Joe Saltel

## Chinook RECORDS

NEW ON CHINOOK LABEL:

- CK-098 OLD HIPPIE by Bob
- CK-097 WHAT A WONDERFUL WORLD by Daryl
- CK-096 YOUR MEMORY WINS AGAIN by Dan
- CK-095 EVERYBODY'S SWEETHEART by Joe
- CK-094 I'LL BE YOUR BABY TONIGHT by Dan
- CK-093 HUMMINGBIRD by Daryl
- CK-092 EVERYBODY'S TALKIN' by Bill
- CK-091 APRIL SHOWERS by Dan
- CK-090 IT'S A SIN TO TELL A LIE by Bob

P.O. Box 919, SP 542  
Apache Junction AZ 85217



Dan Nordbye



Bob Stutevoss



Bill Helms

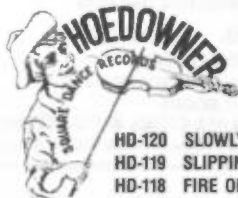

- HD-120 SLOWLY I'M FALLING by Doug Davis
- HD-119 SLIPPIN' AWAY by Mike
- HD-118 FIRE ON THE MOUNTAIN by Jerry
- HD-117 NOW IS THE HOUR by Brian
- HD-116 HOW COULD YOU BELIEVE ME by John



Brian Hotchkies



Jerry Junck



John Kwaiser



Doug Davis



Mike Krehbiel

**GRAND ZIP, Continued**  
tising chairmen.

*Elson & Ruth Brittle  
Arnold, Maryland*

The article [letter] we sent in about our club, Airstream Squares, was supposed to be an invitation for square dancers to dance and camp with us at Oakgrove. We have received numerous inquiries from callers wanting to call for us. We have a marvelous caller, Bill Berry, and would love to have people (square dancers and callers) visit us. We dance the fourth Friday and Saturday of each month except Dec., June, July, August. Be sure to call for directions. Oakgrove is in a U.S. Forest Service Campground near Temecala, California.

*Shirley & Ward Keas  
Torrance, California  
213-540-2666*

"We" will not be renewing our subscription to ASD because "we" (unfortunately) is now just "me." My dance partner of

47 years succumbed to cancer and, as you well know, square dancing is a couples' activity. Until and unless I can find a compatible partner (chances look bleak right now), I am out of the square dance scene. Please know that we enjoyed your magazine immensely; the first thing we did each month was to check the calendar to see where the conventions and weekends were. We did a lot of traveling to square dances—especially Myrtle Beach. I wish you continued success with the magazine.

*Mary Tillman  
Westminster, Maryland*

[Please] ask all advertisers to mark ads with charge card acceptance. From Europe it is otherwise most difficult to transfer funds. Knowing of charge possibility saves writing simply to ask. Some advertisers may also be missing business because they have charge service but are skipped over for some business so listed.

*Carol David-Blackman  
Aachen, West Germany*

*1st Annual*

# **BERMUDA ROUND DANCE FESTIVAL**

**Thursday, Feb. 22 to Tuesday, Feb. 27, 1990**

**PHASES IV - V - VI**  
(Intermediate to Advanced)

**CUERS:**

**Richard & Jo Anne Lawson - Peter & Beryl Barton**  
BIRMINGHAM, ALABAMA HAMILTON, ONTARIO

**AT SONESTA BEACH HOTEL - BERMUDA**  
OFFICIAL CONVENTION HOST HOTEL -

ALL DANCING · DINING · SLEEPING · RELAXING · SOCIALIZING ·  
IN ONE HOTEL!! ALL UNDER ONE ROOF!!

**COME FOR ALL OR PART OF IT! FLIGHTS FROM ALL CITIES & COUNTRIES!**

In Co-operation with Bermuda Department of Tourism and Sonesta Beach Hotel. You must be a Registered Guest at Sonesta Beach Hotel to Attend!



**MAILING ADDRESS**  
**BERMUDA ROUND DANCE FESTIVAL**  
Post Office Box 145  
Avon, Mass 02322 U.S.A. (617) 963-0713



## LLOYD SHAW FOUNDATION INSTITUTE

From June 29 to July 2, the LFS will hold the first in a series of Leadership Training Institutes. Foundation membership includes many well-known square dance, round dance, contra dance and folk dance leaders. The purpose of the institutes will be to share the vast experience of these dance leaders with new or potential dance leaders and to provide a forum for the exchange of ideas and dances among all the participants.

The focus of this year's program will be twofold. There is great need for people who can provide dance leadership for parties and other events involving participants who have never danced before. The first day of this year's institute will be devoted to exploring dance material that can be taught with limited instruction, to be used for theme parties, father-daughter affairs, senior citizens, church events, teen parties, corporate picnics.

Second, the LSF has experienced considerable success in providing dance

camp programs that include a variety of dance forms. Typical LSF dance camps in Colorado, Georgia, New Mexico and Pennsylvania include a mixture of dances. Two days of this year's institute will explore dances that can be used in a mixed dance forms environment.

The focus of the 1989 program will be on square dances, both modern and traditional, round dances, contra dances and folk dances. The students will be given training on how to teach these dances during the daytime workshop and will have opportunity to practice newly learned skills during four evening parties. The syllabus provided to each participant will contain enough materials to support a long term dance program in their home communities.

The setting is a picturesque private boarding school in Canon City, Colorado. Additional information about the LSF Institute and the LSF dance weeks can be obtained by writing Calvin Campbell, 343 Turf Lane, Castle Rock CO 80104.

# GREAT BUYS—AFFORDABLE lace trimmed PETTICOATS

is offering THE SENSATIONAL PETTICOAT at an unbelievable low price.

**ORDER NOW—Money Back Guaranteed**

### THE SENSATIONAL PETTICOAT

- 80 yard
- Double nylon Crisp
- Lace edged
- 1½" elastic adjustable waist
- Adjustable length (snip top)

Adjustable length fits 21", 22", 23"  
Order the shorter for 18", 19", 20" lengths.

Choose from 17 colors: white, black, red, navy, brown, wine, purple, royal, kelly, natural, yellow, peach, pink, med. pink, light blue, and aqua.

The Sensational Petticoat—Reg. \$36.00

**\$29.95**

ORDER NOW

WITH THIS COUPON

ORDER NOW

*Hurry!*

PLEASE SEND TO:

Name \_\_\_\_\_

Address \_\_\_\_\_

City, State, Zip \_\_\_\_\_



**The Catchall**

1813 Ninth Street Wichita Falls, TX 76301 Phone 817/766-1612

#### SHIPPING AND INSURANCE SCHEDULE

Order Total	Acct		
\$ 1-9	1.80	\$50-59	5.20
\$10-19	2.30	\$60-69	5.90
\$20-29	2.80	\$70-79	6.60
\$30-39	3.60	\$80-89	7.50
\$40-49	4.40	\$90-100	8.00

#### DATE OF ORDER

- Shipping (See Schedule)  
 Overseas add proper amt.  TX

QTY	SIZE	COLOR

Items Total \_\_\_\_\_

Shipping \_\_\_\_\_

Tax \_\_\_\_\_

**ORDER TOTAL** \_\_\_\_\_

**STRAIGHT TALK, Continued**  
square dancing with the "climb the ladder—and over the top" philosophy? There is too much emphasis on movements, and not enough emphasis on the fellowship and shared enjoyment.

The program that is building and maintaining square dancing is the Mainstream Program. It is self-sustaining. Mainstream brings them in—and Mainstream keeps us growing. Don't "kill the goose that laid the golden egg."

*Harold Bausch  
Fremont, Nebraska*

**HELP! HELP! HELP!**

The Yampa Valley Squares are asking for help in the return of their traveling Bear, who has not been home in many a long year. We would be eternally grateful to the club/individual who returns our travelworn Bear to us. Expenses will be cheerfully and promptly returned. Mail to Warren and Pat Fread, 556 School St., Craig, Colorado 81625.

*Lester & LaVerne Doyle, presidents*



## DISC-COUNT

Recently Released Records  
Now Available

Information supplied by Hanhurst's Record Service  
PO Box 687, Ridgewood NJ 07451-0687 1-800-445-7398

<p>A Day Late, Larry Letson Beautiful Day, Kip Garvey Boogie Shoes, Tommy Wells Happiness, Paul Binscoe Marty, Patter, Monty Hacker I Hear the South Calling Me, Tom Perry Stagger Lee, Mike Iavarone Blue Blue Day, Don McWhirter Hoedown Blues, Bert Cullop Rise and Shine, Scott Smith Happy Heart, Grace Wheatley Mr. Right, Lee McCormack Cuddle Buggin' Baby, Al Saunders Slowly I'm Falling, Doug Davis Rhythm Is Gonna Get You, Craig Rowe Dancin' Shoes, Art Springer Ridin' My Thumb, Don Day I Don't Think She's In Love Anymore, Bob Price Be-Boo-A-Lula, Max Arnold I'm Just Wild About Mary, Johnnie Wykoff My Guiding Star, Johnnie Wykoff With/Without, Patter That Old Wheel, Joe Porritt Little Girl, Elmer Sheffield Slow Boat to China, Michael Johnstone I'm Made For Dancing, Tom Manning Heartbreak Express, Wes Dyer &amp; Kenny Jarvis Train of Thought, Ron Mineau Pancho &amp; Lefty, Bob Wilcox Deeper Than the Holler, Shane Greer When Irish Eyes are Smilin', Johnny Cree Takes A Lot of River, Beryl Main Kokomo, Bruce McCue (LP) Dances &amp; Mixers #2, Jack Murtha Gypsy Contra, Paul Moore</p>	<p>Royal 502 Royal 701 Lou Mac 170 Song 308 Big Mac 1007 H-Hat 5113 TNT 269 SD 203 SD 204 Chaparral 810 Desert 38 Rawhide 154 Bucksin 1229 Hoedown 120 ESP 710 Quadriple 861 Red Boot Star 1319 Lightning 302 Lightning 402 Blue Star 374 Blue Star 2375 Blue Star 2376 Jo Pat/ESP 232 ESP 157 White Knight 012 Solid Gold 201 Ems 2402 Big Mac 094 Cross Country 512 Cross Country 511 Blue Star 2377 Chaparral 413 Silver Sounds 109 SD 503 Windsor 5130</p>
---	--



## EAGLE RECORDS



**Jim "Who" Logan**



**"Little Joe" Goins**



**Jim "Who" Cholmondeley**



**James "007" Andy Bond**

**EAGLE ENTERPRISES**  
11220 Florissant St., Suite 169  
Florissant MO 63032  
Phone 314-653-1441

**RECENT RELEASES**

EAG 1902 IN LOVE, Andy Bond  
EAG 2010 ABILENE, Joe Goins  
EAG 2011 TWO OLD CATS LIKE US  
Joe Goins & Jim Logan  
EAG 2101 GUITARS, CADILLACS & HILLBILLY MUSIC  
Jim Cholmondeley



**Herb Edwards**



**Gene Warrington**



**Walt Ishmael**

**KELTONE PRODUCTS**  
Basic Book  
5-Year Calendar  
810-A & 975 Mic  
Hilton Mic Cont  
A/C Adaptor

**NEW RELEASES**

EAG 2012 TURN IT LOOSE	Joe Goins	EAG 1209 OLD LAMPLIGHTER	Jim Logan
EAG 2102 FULL GROWN FOOL	Jim Cholmondeley	EAG 2103 ONE STEP	Jim Cholmondeley
EAG 1208 CRAZY OVER YOU	Jim Logan	EAG 2202 INDIAN LAKE	Herb Edwards
EAG 2201 CANDY MAN	Herb Edwards	EAG 2013 BLOWING IN THE WIND	Joe Goins
EAG 2301 OLE TIME ROCK AND ROLL		EAG 2401 BORN TO BOOGIE	Walt Ishmael
	Gene Warrington	EAG 2104 THINGS	Jim Cholmondeley



Jack O'Leary

## Silver Sounds Records



Bruce McCue

### LATEST RELEASES:

- SSR 108 **ANOTHER PLACE, ANOTHER TIME** by Red Bates
- SSR 107 **SATURDAY NIGHT SPECIAL** by Jack and Bruce
- SSR 106 **DADDY'S LITTLE GIRL** by Jack
- SSR 105 **UNDER THE BOARDWALK** by Bruce
- SSR 104 **COMIN' TO AMERICA** by Jack and Bruce
- SSR 103 **JACK OF DIAMONDS** by Jack
- SSR 102 **ANOTHER SATURDAY NIGHT** by Jack and Bruce
- SSR 101 **ONE OF THOSE SONGS** by Bruce

Records available at your local dealer

Distributed by SUNDANCE, TWELGRENN, ASTEC and MERRBACH

SILVER SOUNDS RECORDS • P.O. Box 229 • Glastonbury, CT 06033  
(203) 633 - 0370 • OR • (203) 529 - 0937

# Meg Simkins

119 Allen Street  
Hampden, Mass. 01036

Everything  
for Square Dancers

Send \$1.00 for Catalog  
Refunded on First Order

## # P-700 Nylon Ruffles

100 yards of soft nylon Tricot Ruffling is used to trim this very full three skirt nylon "horse hair" bouffant. This is not only a very durable but beautiful garment. Heavy elastic waistline is double stitched for comfort and long wear.

- Colors:
- Purple/Purple Ruffle
  - Black/Black Ruffle
  - White/White Ruffle
  - Hot Pink/Hot Pink Ruffle
  - White/Multi-colored Ruffle
  - Pink, Blue & Yellow
  - White/Multi-colored Ruffle
  - Red, White, Navy
  - Red/Red Ruffle
  - Soft Pink/Soft Pink Ruffle
  - Yellow/Yellow Ruffle
  - Blue/Blue Ruffle
  - Brown/Brown Ruffle
  - Orange/Orange Ruffle
  - Burgundy/Burgundy Ruffle
  - Rust/Rust Ruffle
  - Peach/Peach Ruffle

### \$25.00



- Sizes: Small, Medium & Large  
Length: 19" 21" 23"  
Please give waist size & length desired

Handling  
\$2.50 each



### COVERED WAGONS

As a way to publicize the 38th National Convention, the Publicity Committee constructed nine tiny covered wagons and sent them out over the country, to make their way back to Oklahoma City. Wagons have been taken from club to club, and to jamborees and festivals. Cards have been received from Washington, Utah, Florida (2), California, New Jersey, Tennessee, Indiana and North Carolina, where the wagons started, and from Alaska, Oregon, Montana, Idaho, Min-

nesota, Iowa, Arkansas, Georgia, Illinois, Michigan, Pennsylvania, Virginia, Delaware and South Carolina. All the cards will be on display at the Myriad Convention Center during the convention.

### REGISTRATION

Total registration as of the last news release was 10,054.

### BARBECUE

Moe Bandy will perform at the kick-off barbecue on June 21. This performance will be open only to those square dancers attending the barbecue. Tickets must be purchased in advance. They will not be sold at the time of the barbecue. For more information or to purchase tickets for \$9.50 each, write to Louis and Billie Briscoe, Rt. 2 Box 15, Yukon OK 73099.

### SHOWCASE OF IDEAS

Visit the Showcase of Ideas and Publications Display to see what associations have done and are doing in square dancing. Don't miss it!



# Fashions from Texas by Nita Smith

2011 So. College Ave.  
Bryan, Texas 77801  
Telephone (409)822-2337

WHOLESALE ACCOUNTS WELCOME

Write for Complete Catalogue

## NEW 'DC-9'S ABOVE THE CLOUDS'

**DOUBLE LAYER PETTICOATS...**Two layers of nylon organza proportioned to please the most discriminating dancer!!!

40yd	50yd	60yd	70yd	80yd	100yd
\$46.95	\$51.95	\$55.95	\$63.95	71.95	\$69.95

Apple, Aqua, Beige, Black, Bluebell, Blue (Lt.), Brown, Candlelight, Candy Pink, Cerise, Coral, Dusty Rose, Fuchsia, Ivory, Kelly, Lavender, Lilac, Maize, Mint, Navy, Orange, Peacock, Pink (Lt.), Purple (Med.), Purple (Dk.), Red, Royal, White, Wine, Yellow.

## CLOUD NINE NYLON ORGANZA

SOLID COLOR:	40yd	50yd	
	\$41.95	\$45.95	
	60yd	70yd	80yd
	\$48.95	\$56.95	\$63.95

To cover postage and handling costs, add \$3.00 per petticoat





Darryl McMillan

# RANCH HOUSE RECORDS



Bill Terrell

### NEW RELEASES:

RH223 DO THE LOCOMOTION by Darryl  
RH906 EVERYBODY NEEDS A HERO by Mark

### NEW PATTER:

RH105 ROLLIN' EASY  
RH106 R.P.M.

### WE HAVE PLENTY...

RH104 BREEZIN' EASY

### AVAILABLE



Mark Turner



Keith Rippetto

PLEASE WRITE FOR FREE CATALOG  
AND SPECIAL RECORD DEAL!

### 2nd ANNUAL CALLERS COLLEGE

June 4-9, 1989 Darryl McMillan, Inst.  
Panama City, Florida Limited Openings

### RANCH HOUSE ROUND-UP May 5-6, 1989

Darryl McMillan, Bill Terrell, Tony Oxendine  
Panama City Beach, Florida

WRITE OR CALL FOR INFORMATION, PO Box 880, Lynn Haven FL 32444 Ph. 904-265-2050



She'd be  
smiling more  
if she read  
**American Squaredance!**

**SIGN UP NOW**

Please start my subscription NOW. My check (or money order) is enclosed.

- One Year at \$12       Two Years at \$22  
Canadian and Foreign add \$1 per year postage.

NAME \_\_\_\_\_

ADDRESS \_\_\_\_\_

CITY \_\_\_\_\_

STATE \_\_\_\_\_ ZIP CODE \_\_\_\_\_



Double Your Pleasure  
Double Your Fun!



CAMPING AND SQUARE  
DANCING ROLLED INTO  
ONE.

## NATIONAL SQUARE DANCE CAMPERS ASSOC.; INC.

For more information contact:

**Dept. B P.O. Box 224  
Little Chute, WI 54140**

Over 150 Chapters in 37 States & Canada

**Montana**—Square & Round Dance Center, 9955 Hwy 12, Lolo MT 59847.

**New Mexico**—The Community House, Summer: PO Box 213, Red River NM 87558. Winter: Rt. 1 Box 42, Clinton OK 73601.

**South Dakota**—Darlot/Doris Curtis, 201 N Platt St, Rapid City SD 57702-0361.

**Tennessee**—English Mountain, Rt. 6 Box 212, Sevierville TN 37862.

### THIS MONTH'S PUZZLE ANSWERS

BEAT CLAP ASD  
LABEL OPAL ME  
USE ADIOS VIA  
RE GUEST BILL  
SIDE HLA E  
TREE TEXAS A  
ANT NAOMI HOG  
G SHINE JANE  
B ALA MEOW  
HUSH HEELS DO  
UFO REELS FUN  
NF NEIL EMCEE  
GYM OMSK SASS

### Rita's Quiltique

*A Square Dancers Exclusive!!*

**SQUARE DANCERS QUILT-TOP KIT** includes:

- 30 pre-cut stamped, white blocks, to be appliqued & embroidered.\*
- 30 pre-cut solid color blocks.
- Enough solid color fabric for final binding.
- Patterns for applique pieces.
- Full instructions for appliqued blocks AND ASSEMBLY.
- \* - Use left-over fabric from your dresses.



Available in queen/double size only  
Finished size approximately 82 x 102  
Batting & backing NOT INCLUDED

**Only \$39.95** plus \$3.60 postage  
& handling (\$5.00 U.S. for Can. residents)  
QUILTING TEMPLATES \$2.50  
Sold only with quilt kits



—COLORS—  
Pastel Blue Royal Blue Navy Blue Pink Red  
Rust Brown Green Gold Rose  
Yellow Berry (Please specify color when ordering)



RITA DAVIS  
96 Palace Drive  
Dayton, Ohio 45449  
513-859-3824

DIY OF  
RUFFLES IN CUCS

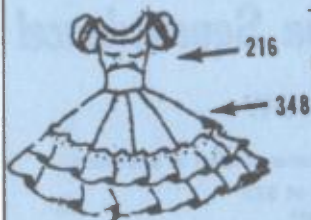

*Vee Gee*



**Pattern Co.  
Box 23  
Hamlin, Texas 79520**

Catalog \$1.50  
plus 50¢ postage & handling

# MERRBACH RECORD SERVICE

## BLUE STAR RELEASES:

2379 WISHPFUL THINKING, Helen Maddeaux	Round Dance
2378 CINCINNATI WALTZ QUADRILLE, Jerry Helt	Square Dance
2377 WHEN IRISH EYES ARE SMILING, Johnny Creel	Square Dance
2376 WITH/WITHOUT	Flip Hoedown
2375 MY GUIDING STAR, Johnnie Wykoff	Square Dance
2374 I'M JUST WILD ABOUT MARY, Johnny Wykoff	Square Dance
2373 SMILE DARN YA SMILE, Johnnie Wykoff	Square Dance
2372 STAR'S HOEDOWN #1/PLUS Patter on Flip	Square Dance

## DANCE RANCH RELEASES:

698 CAN'T STOP MY HEART, Chuck Myers	Square Dance
697 WE GOT THE MEMORIES, Chuck Myers	Square Dance

## BOGAN RELEASES:

1379 CRAZY RHYTHM, John Aden	Square Dance
1378 NAOMI, Ken Jeffries	Square Dance

## LORE RELEASES:

1237 BY THE SEA, Johnny Creel	Square Dance
-------------------------------	--------------

## PETTICOAT PATTERN RELEASES:

129 YELLOW BIRD, Dorothy Juntti	Square Dance
128 COWBOY'S SWEETHEART, Dorothy Juntti	Square Dance

**WE STOCK MOST SQUARE AND ROUND DANCE LABELS:** CHAPARAL, ESP, RED BOOT, WINDSOR, WAGON WHEEL, RANCH HOUSE, RAWHIDE, RHYTHM, LOU MAC, HI-HAT, STING, SNOW, GRENN, CHINOOK, FOUR BAR B, JOPAT, KALDX, SCOPE, TNT, ROYAL, EUREKA, BIG MAC, CIRCLE D, QUADRILLE, GOOD VIBRATIONS, and many others.

**SCHOOL AND PRE-SCHOOL RECORDS AND TAPES:** KIMBO, MELODY HOUSE, EDUCATIONAL ACTIVITIES, BOWMAR and others.

**A GOOD LINE OF MICROPHONES IN STOCK:** Electro-voice, AKG, Shure, Audio-Technica, Passo and Astatic. We have Williams Wireless and Samson Systems.

**FOR YOUR TAPING NEEDS:** "Blank Cassettes" 5-Minute, 15-Minute, 30-Minute, 45-Minute, 60-Minute and 90-Minute with or without boxes, labels extra.

**WE STOCK:** Ampex 456 Grand Master reel to reel in 2-Inch, 1-Inch, 1/2-Inch and 1/4-Inch. Quarter inch in bulk pancakes also. (2500 feet x 1/4 inch)

**WE SELL AND SERVICE A COMPLETE LINE OF "CALIFONE" PRODUCTS**—For dance schools, pre-schools, cloggers, square dance and churches.

**WE SERVICE AND REPAIR AND HAVE PARTS FOR:** Some Newcombs — Califone — Hilton

**SOUND CONSULTANTS:** Bids and estimates for S/D halls and churches.

**NEW RELEASES**—Tape Service for only \$24.00 per year subscription. This service will help you select your latest singing calls and hoedowns soon after they reach our store. You keep the tape! Write or call today for a Free Sample.

*When in Houston come see us:*

Monday thru Friday

Saturday

8:30 AM to 5:00 PM CST

9:00 AM to 1:00 PM CST

*If placing an order after hours, by phone, recorder will answer (4th ring)*

713-862-7077

## MERRBACH RECORD SERVICE

PO Box 7309, Houston, TX 77248-7309

323 West 14th, St., Houston TX 77008



NORMAN MERRBACH



NADINE MERRBACH



JOHNNIE WYKOFF



Elmer Sheffield Jr.



QUALITY MUSIC BY:  
SOUTHERN SATISFACTION



Bob Newman

**NEW RELEASES**

- ESP 157 LITTLE GIRL by Elmer
- ESP 521 COMPANY'S COMING by Bob
- ESP 710 RHYTHM IS GONNA GET YOU by Craig
- ESP 156 THE LOCOMOTION by Elmer
- ESP 155 I DON'T KNOW WHY by Elmer
- ESP 709 SHA-BOOM by Craig
- ESP 519 I'VE HAD THE TIME OF MY LIFE by Bob
- ESP 520 ME AND MY SHADOW by Bob



Craig Rowe

**HOEDOWN**

ESP 406 G-STRING with Plus Calls by Elmer

**ROUNDS**

ESP 013 BLUE MOON, Round by Jim  
 ESP 012 SENTIMENTAL JOURNEY by Jim



Jim & Dottie McCord



by ESP

MUSIC BY:  
SOUTHERN SATISFACTION



JOE PORRITT

**BRAND NEW RELEASES:**

- JP/ESP 232 THAT OLD WHEEL by Joe
- JP/ESP 121 I NEVER SEE MAGGIE ALONE by Elmer
- JP/ESP 120 MY WINDOW FACES THE SOUTH by Elmer
- JP/ESP 230 I HAVE YOU by Joe
- JP/ESP 231 JOE SURE KNOWS HOW TO LIVE by Joe



ELMER SHEFFIELD

ESP, 2213 S. Adams St., Tallahassee FL 32301

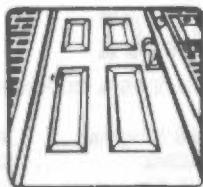

# Book Nook



by Mary Jenkins

## A FUN ENCYCLOPEDIA OF SOLO AND LINE DANCES The Steps That Came and Stayed by Ollie Mae Ray, PhD.

Within the 234 pages of this book one will find a vast amount of information that will be helpful and of great interest to present, past, and future teachers or students of line and solo dancing.

The Table of Contents is in alphabetical order. A list of abbreviations, diagrams for the feet, a Glossary of Terms, and a bibliography are also given.

Each of the nearly 100 dances has a bit of information about its origin, a list of records to be used, the formation, steps

and directions for the dance.

The author believes that anyone who follows the directions carefully can learn the dances. She suggests that if one has difficulties, he or she should start over from the beginning and learn each step, then proceed to learning the whole dance.

The cost of the book is \$14.95 plus \$2 p. & h. Order from Siddall & Ray Foundation, Inc., c/o Dr. Ollie M. Ray, 549 Walton Dr., Educational Mailing Div., Whitewater, WI 53190

### EXPERIENCE A NEW WORLD OF HEARING... WITH THE PERSONAL PA SYSTEM

SQUARE DANCERS, THIS IS FOR YOU!

*Worship Services, concerts, movies — things that most of us take for granted — are not part of the everyday life of those who are hearing impaired.*

Even for a hearing aid user, listening in an auditorium can be a problem, because hearing aids amplify all sounds, including surrounding background noises.

#### A new listening experience from Williams Sound.

With the help of a Williams Sound Personal PA System, hearing impaired people can enjoy a new listening experience, uninterrupted by the annoying sounds of shuffling feet, the rustle of paper, and the murmur of voices. Since the message is broadcast directly from the microphone to the listener, only the sounds which are intended to be heard reach the listener's ears.

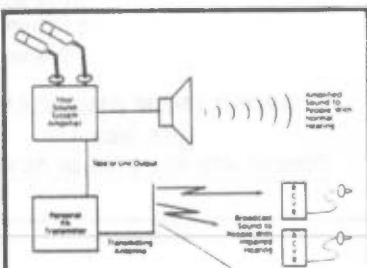

#### Listeners enjoy wireless listening freedom.

The Personal PA System features an FM Transmitter that connects to an existing sound system, typically using a tape output connection from the amplifier or mixer. Optional Transmitters are available for facilities that do not have a sound system. The Transmitter acts as a miniature radio station, broadcasting over a radius of 300 feet or more, directly to the listener's Personal PA Receiver. Because the Personal PA is wireless, listeners are free to sit with their family and friends, not isolated and conspicuous in the "deaf row".

FOR FURTHER INFORMATION: CALL 1-800-282-4726  
GRAND TRAVEL SQUAREDANCE SHOPPE, PO BOX 690092, TULSA, OK 74169

# SQUARE DANCE BOOK SERVICE

35 VARIETIES — BOOKS FOR CALLERS, CUERS, LEADERS, DANCERS & CLOGGERS

ACCOMPLISHING BETTER CALLING.....	\$4.00	MAINSTREAM S/DANCING (Diagrams).....	\$1.00
ALLEMANDE LEFT (Mentally Handicapped).....	\$5.00	MODERN CONTRA DANCING.....	\$3.00
APPALACHIAN S/D FOR CLOGGERS.....	\$10.00	MODERN MODULE MODE (Figures).....	\$3.00
CALLER CLINIC (Variety of subjects).....	\$6.00	PARTY LINE (After-party ideas).....	\$6.00
CALLER'S GUIDEBOOK (300-page text).....	\$14.00	PLUS PROGRAM (Diagrams).....	\$1.00
CHOREOGRAPHY GIMMICKS.....	\$6.00	PROGRESSIVE WORKSHOP (Variety).....	\$3.00
CLIP ART I (Sketches, paste-up).....	\$3.00	SET-UP AND GET-OUT (Modules).....	\$6.00
CLIP ART II (All different).....	\$4.00	SHOW AND SELL S/D (Better promotion).....	\$8.00
CLOGGING (Basic book).....	\$4.00	SOLO DANCES (Single, line routines).....	\$7.00
EASY LEVEL (O/N/S Material).....	\$6.00	SOUNDING THE HALL (Equipment).....	\$3.00
EASY SING-A-LONG (Adaptations).....	\$3.00	S/D STYLING (Smoother dancing).....	\$4.00
FIRST STEPS TO CONTRA (Basic).....	\$3.00	TEACHING CLOGGING.....	\$7.00
FUNNY WORLD OF S/D (Cartoons).....	\$4.00	TEACHING TOTS TO DANCE (Family).....	\$3.00
GOOD CLUB MANAGEMENT.....	\$4.00	WHEEL AND DEALING (Nursing Homes).....	\$5.00
GUIDEBOOK FOR SQUARE DANCERS.....	\$2.00	WINDMILL SYSTEM (Image style).....	\$5.00
HOEDOWN HERITAGE (History).....	\$3.00	WORTH OF A SALESMAN (Showmanship).....	\$10.00
LEADERSHIP-SHAPE (Tips galore).....	\$7.00		

POSTER PAK-1, PAK-2, PAK-3 (cartoons for fun & instruction).....\$10.00 each  
 DIPLOMAS: SQUARE, ROUND, CLOGGING.....20¢ each; 100—\$15.00  
 PROMOTIONAL FOLDERS.....100 for \$10.; Quantity prices for 300 & 500  
 MAGAZINE CASE (Holds one year's issues).....\$3.00  
 IN-FORMS (guides, helps; 150 subjects).....35¢/1; Ask for quantity prices

## POSTAGE

\$1-\$4.99...\$1.25 pstg.

\$5-\$9.99...\$2.00 pstg.

\$10 & up...\$2.50 pstg.

ORDER FROM AMERICAN SQUAREDANCE MAGAZINE

P.O. Box 488 HURON OH 44839

Phone: 419-433-2188 or 5043 (During EST Business Hours)

## FINISH LINE

A penny saved is more than a penny earned.

You've got to figure taxes in there somewhere.

—Dick Conway



# THE SWING THRU.

**April Special**

Beige Angeline Blouse.

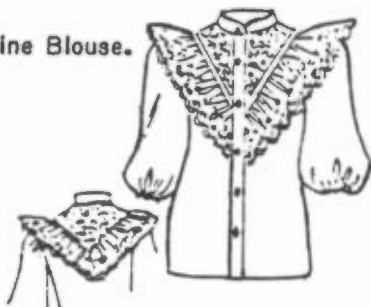

Brown Ginger Skirt.

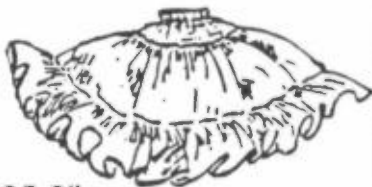

Beige or Brown 005 Slip.



Mens Scarf.

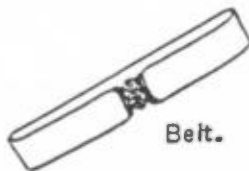

Belt.

**ONLY \$70.00**

**Reg. \$92.00**

Add \$5.00 for Shipping

The Swing Thru  
P.O. Box 231  
Swiftwater PA 18370  
(717)839-8200

Special good through the last day of the month or until supplies run out.

# LAUGH LINE



## HANHURST'S TAPE & RECORD SERVICE Since 1971

### The "Original" Monthly Tape Service

- Contains All New Square Dance Music
- Fast, Professional Service
- Subscriber Discounts
- TOLL FREE Order Phone

The Continuing Choice  
of more than 1,300 Callers.

**FREE SAMPLE TAPE!**



**1-800-445-7398**  
(In N.J. 201-445-7398)



P.O. BOX 687  
RIDGEWOOD, N.J. 07451-0687

CHAPARRAL  CHINOOK  RHYTHM  4-BAR-B  BELCO

RAWHIDE  HI HAT  GRENN  BLUE STAR  RED BOOT

ROYAL  STING  SNOW  ESP

# English Mountain

AMERICA'S NEWEST AND FINEST SQUARE DANCE RETREAT

2 DAY WEEKEND SCHEDULE 1989

<b>APRIL 28-30 (**)</b> Charmal Recording Show Ken Bomer (CA) Gary Shoemaker (TN) Jenny Hoad (TX) Scott Smith (AZ) Bert, Man (CO) Ray/Bea Dancy (WV) [R]	<b>MAY 5-7</b> "Single Weekend" George Langner (AL) Gerry Shoemaker (TN) Some Love (NC) [R]	<b>MAY 12-14</b> Buddy Allison (GA) Bill McVey (GA)	<b>MAY 19-21</b> Ron Ditt (IN) Sharon Ditt (IN) [R]	<b>MAY 26-28</b> Jae Price (VA) Ruth Maves (VA) [R]	<b>JUNE 2-4</b> Cand Johnson (OH) Cecil Sams (WV) Bl./Sandy Bush (WV) [R]	<b>JUNE 9-11</b> Jenny Bassinger (NC) Dana Cox (NC) Bl./Eva Anderson (WV) [R]
<b>JUNE 16-18</b> Bl. Blackman (OH) Ron Eversaw (IN) Jude Eversaw (IN) [R]	<b>JUNE 23-25</b> Rae Donoho (TN) Ron Hales (GA) Clay/Earl Jordan (TN) [R]	<b>JUNE 30-JULY 2</b> Chuck Meyers (AL) Sue Dues (OH) Dorothy Roma (OH) [R]	<b>JULY 7-9 (**)</b> Red Boot Boys Strick "Live Music" Souls & Rouses	<b>JULY 14-16</b> Henry McCaslin (WV) George Shell (VA) G. W. Wines (VA) [Coed] Folk/Live (SD Sings Only)	<b>JULY 21-23</b> Glad "Ol' Boy" Sue Dues (OH) Mae King (OH) Kathleen Zastrow (OH)	<b>JULY 28-30</b> Mack Little (AL) Jai Hysack (AL) Wilson/Ava McCaslin (AL) [R]
<b>AUG. 4-6</b> Happy Lacey (NC) Mel Epps (AL) Mae Patterson (KY)	<b>AUG. 11-13</b> Paul Koldover (IN) Karin Rossow (KY) Paul VanOverbeek/Ron Bolton (OH) [R]	<b>AUG. 18-20</b> Ken Bure (IL) Burt/Mary Tracy (IN) [R]	<b>AUG. 25-27</b> Gene Record (KY)	<b>SEPT. 1-3</b> The Red Boot Boys (TN)	<b>SEPT. 8-10</b> Sue Long (SC) Morris Forester (NC) [R]	<b>SEPT. 15-17</b> Eddie Powell (OH)
<b>SEPT. 22-24</b> Wendell Longmire (GA)	<b>SEPT. 29-OCT. 1</b> Coley Dyer (AL) Dawn Weiss (GA) John/Betty Gentry (MS) [R]	<b>OCT. 6-8</b> Bill Stern (OH)	<b>OCT. 13-15</b> Mae Hoot (TN) Wendy McDonald (TN) Bill Harmon (MO) Dix Smith (TN) [R]	<b>OCT. 20-22</b> Harold Kelley (GA) John Sengle (GA) Hau/Sue Rosen (GA) [R]	<b>OCT. 27-29</b> Don Williamson (TN) Paul/Eleanor/David Hines (NC) [R]	<b>NOV. 3-5</b> Paul Marshall (TN) Ruth/Mary Southworth (KY) [R]

ALL WEEKS PLUS UNLESS INDICATED OTHERWISE (\*\*) DENOTES SPECIAL DATES, PLEASE CALL FOR PRICE INFORMATION.

LEISURE SUITES AND CONDOS AVAILABLE. ALSO CAMPGROUND (RV SITES) WITH FULL HOOKUPS

PLUS THESE FACILITIES FOR YOUR USE: HEATED POOL, LIGHTED TENNIS COURTS, MINI-GOLF, HORSESHOES, GIFT SHOP, SHUFFLEBOARD AND 2 WHIRLPOOL HOT TUBS.

FOR MORE INFORMATION CONTACT ENGLISH MOUNTAIN SQUARE DANCE RETREAT, RT. 6, BOX 212, SEVIERVILLE, TN 37862; OR CALL 615-453-0171

# English Mountain

AMERICA'S NEWEST AND FINEST SQUARE DANCE RETREAT

5 DAY SCHEDULE 1989

<b>APRIL 23-28 (**)</b> Ken Bomer (CA) Toy O'Donoghue (SC) Jenny Story (TX) Ray/Bea Dancy (WV) [R]	<b>APRIL 30-MAY 5</b> Walt Brown (CA) Chuck Dancy (FL) Bob/Vivian Burkner (FL) [R]	<b>MAY 7-12</b> "Round Wink" Tom/Jan Keweler (KY) Ron/Eve Yarnack (KY) Ruth/John Collins (NY) "Columbia Square" (**) Wade Dancy (TX) Gary Shoemaker (TN)	<b>MAY 14-19 (**)</b> "Round Wink" Betty/Eddie Hartday (MO) Phyllis V. V. VI (Dancers & Teachers)	<b>MAY 21-26</b> Wendy Morrison (TX) Doc Gary (FL) Jesse/George Colson (FL) [R]	<b>MAY 28-JUNE 2 +</b> "Single Wink" Tom Morrison (VA) Mae Claborn (OH)	<b>JUNE 4-9 +</b> Ava Price (AL) Bobby Newsum (KY) Mae Turner (KY) Nancy/Wally Carter (KY) [R]
<b>JUNE 11-16 +</b> Bob Hurt (MO) Pat Donoho (AR) Jenny/Dot Yodley (KS) [R]	<b>JUNE 18-23</b> Ken Bomer (CA) Diane Cassell (TX) Mae/Pat Price (TX) [R]	<b>JUNE 25-30</b> Lee Greenwood (OH) Lorne Loomer (CA) New or Actual 1st Break (CA) [R]	<b>JULY 2-7</b> Margaret Flinn (TX) Dew/Lisa Padden (PA) [R]	<b>JULY 9-14</b> Jenny Stone (TX) LARRY LITTON (TX) Jae/Jan Pookman (IL) [R]	<b>JULY 16-21</b> Flossie Gentry (OH) Scotty Swisher (OH) Gwendolyn/Carolyn Hays (OH) [R]	<b>JULY 23-28</b> Lee Man (OH) Dale Taylor (MO) Bob/Marian Collier (KS) [R]
<b>JULY 30-AUG. 4</b> Wade Dancy (TX) Tom Morrison (VA) Bl./Betty Lacey (AR) [R] "Columbia Square" (**) Jack Lacey (FL) Evel Johnston (CT)	<b>AUG. 6-11</b> Garry Ross (IN) Art Tamm (OH) Dore/Gus Blaine (OH) [R]	<b>AUG. 13-18</b> Jae Price (MI) Dorey Rossow (FL) Cecily/Sue White (MI) [R]	<b>AUG. 20-25</b> Tom Miller (PA) LARRY PHOEN (FL) LARRY PHOEN (FL) [R]	<b>AUG. 27-SEPT. 1</b> John Carlton (MO) Pete Dyer (MO) R.L. Hesse (FL) Sharon/Wendy Givens (FL) [R]	<b>SEPT. 3-8</b> Ron Sohier (FL) Bud/Diane Miller (OH) [R]	<b>SEPT. 10-15</b> Harold Rosen (MO) Loren Conner (MO) Gene/Gus McMullin (MO) [R]
<b>SEPT. 17-22</b> Vicki Taylor (IN) John Paul Brennan (AL) Pat/Larry Wolf (IN) [R]	<b>SEPT. 24-29</b> LARRY LITTON (TX) Lew Gentry (LA) Mae/Curt Hoad (MI) [R]	<b>OCT. 1-6</b> Ken Bomer (CA) Garry Shoemaker (TN) Ronard/Jeanne Lamm (AL) [R]	<b>OCT. 8-13</b> Bill Harmon (MO) Mae Hoot (TN) Wendy McDonald (TN) Tom/Jan Keweler (KY) [R]	<b>OCT. 15-20</b> Raeon Meehan (OH) Jenny Lee (CA) Lloyd/Eileen Loomer (PA) [R]	<b>OCT. 22-27</b> Tom Ochsner (SC) Jenny Story (TX) Jae/Phyllis Acock (VA) [R]	<b>OCT. 29-NOV. 3</b> Sue Gentry (AL) Bl. Yoder (MO) Bob/Maria Buck (LA) [R]

ALL WEEKS PLUS UNLESS INDICATED OTHERWISE (\*\*) DENOTES SPECIAL DATES, PLEASE CALL FOR PRICE INFORMATION. DIRECTOR, GARY SHOEMAKE, WILL CALL EACH 5 DAY PROGRAM WITH THE SCHEDULED STAFF EXCEPT FOR WEEKS INDICATED WITH A +.

LEISURE SUITES AND CONDOS AVAILABLE. ALSO CAMPGROUND (RV SITES) WITH FULL HOOKUPS

PLUS THESE FACILITIES FOR YOUR USE: HEATED POOL, LIGHTED TENNIS COURTS, MINI-GOLF, HORSESHOES, GIFT SHOP, SHUFFLEBOARD AND 2 WHIRLPOOL HOT TUBS.

FOR MORE INFORMATION CONTACT ENGLISH MOUNTAIN SQUARE DANCE RETREAT, RT. 6, BOX 212, SEVIERVILLE, TN 37862; OR CALL 615-453-0171

# English Mountain

AMERICA'S NEWEST AND FINEST SQUARE DANCE RETREAT

July 2-7, 1989

MARSHAL FLIPPO  
TEXAS

GARY SHOEMAKE  
TENNESSEE

DAN & LINDA PROSSER  
PENNSYLVANIA

5 DAY RATE SCHEDULE

LEISURE SUITE OR CONDO (ACCOMMODATIONS DEPEND ON AVAILABILITY) PRICES BASED ON DOUBLE OCCUPANCY.  
5 DAY PACKAGE: \$275.00 PER PERSON / \$550.00 PER COUPLE; 3RD OR 4TH PERSON SHARING SAME ACCOMMODATIONS: \$245.00 EACH (LIMIT 2)

5 DAY PACKAGE IS FROM SUNDAY DINNER THRU FRIDAY BREAKFAST AND INCLUDES THE FOLLOWING: LEISURE SUITE OR CONDO - ALL MEALS - ALL DANCE SESSIONS AND ADMISSION TO THE SMOOKY Mtn. JUBILEE SHOW. CHECK IN 3:00 P.M. SUNDAY, CHECK OUT 10:00 A.M. FRIDAY.

SINGLE OCCUPANCY ON ABOVE IS \$462.50 • CHILDREN'S PRICES UPON REQUEST

CAMPGROUND (RV SITES) (FULL HOOK UPS AVAILABLE) - PRICE INCLUDES ALL MEALS  
5 DAY PACKAGE: \$210.00 PER PERSON / \$420.00 PER COUPLE; 3RD OR 4TH PERSON SHARING SAME CAMPER \$180.00 EACH (INCLUDES SAME AS ABOVE)

PLUS THESE FACILITIES FOR YOUR USE: HEATED POOL, LIGHTED TENNIS COURTS, MINI-GOLF, HORSESHOES, GIFT SHOP, SHUFFLEBOARD AND 2 WHIRLPOOL HOT TUBS.

ENGLISH MOUNTAIN SQUARE DANCE RETREAT  
RT. 6, BOX 212 • SEVIERVILLE, TN 37862  
FOR MORE INFORMATION CALL: 615-453-0171

(NO CHARGE CARDS ACCEPTED. ALL PRICES SUBJECT TO TENNESSEE SALES TAX. \$50.00 DEPOSIT MUST ACCOMPANY ALL REGISTRATION FORMS AND IS REFUNDABLE UP TO 30 DAYS PRIOR TO SCHEDULED ARRIVAL, LESS A \$10.00 PROCESSING FEE.)

NAME (His) \_\_\_\_\_ (Hers) \_\_\_\_\_ LAST \_\_\_\_\_  
ADDRESS \_\_\_\_\_ CITY \_\_\_\_\_ STATE \_\_\_\_\_ ZIP \_\_\_\_\_  
PHONE ( ) \_\_\_\_\_ DATE OF ARRIVAL \_\_\_\_\_ PREVIOUS # OF TIMES ATTENDED \_\_\_\_\_  
WEEK YOU WISH TO ATTEND \_\_\_\_\_ CALLER'S NAME \_\_\_\_\_  
LEISURE SUITE \_\_\_\_\_ CONDO \_\_\_\_\_ CAMPGROUND \_\_\_\_\_