

352.0742b  
W58  
2007  
c.2

# ANNUAL REPORT



**NEW HAMPSHIRE**  
1804-2007

For year ended December 31, 2007



352-07426  
WSP  
2007  
2007

# ANNUAL REPORT

TOWN OF WHITEFIELD  
NEW HAMPSHIRE  
FOR YEAR ENDING  
DECEMBER 31, 2007

N. H. STATE LIBRARY  
MAY 12 2008  
CONCORD, NH

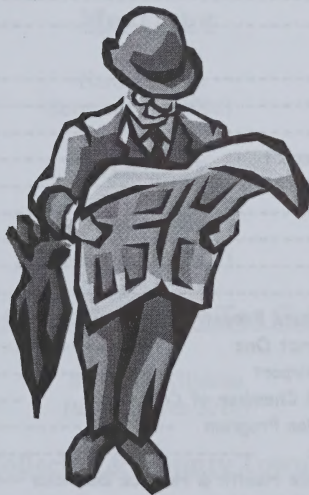

This report was printed by Sherwin Dodge Printers

Polls Open 8:00 A.M. - 6:00 P.M.

Please bring report to Town Meeting  
Business Meeting - Tuesday, March 11, 2008  
At 7:30 P.M.

C.D. McIntyre Building - Auditorium

# INDEX

Town Officers	3
Telephone Directory	7
2007 Annual Town Meeting Minutes	8
2007 Tax Rate Calculation	19
2007 Summary of Valuation	20
Comparison of Tax Rate	21
Sewer Department Financial Statement	22
Water Department Financial Statement	23
2007 Inventory of Town Property	25
Town Clerk's Report	27
Dog Licensing Reminder	28
Vital Statistics - Marriages	29
Vital Statistics - Births	31
Vital Statistics - Deaths	33
Tax Collector's Report	36
Treasurer's Report	38
2007 Statement of Estimated & Actual Revenue	40
2007 Detailed Statement of Payments	41
2007 Payroll by Department	47
Town Warrant & Town Budget	Center Insert
Trust Funds Report	49
Reports of:	
Fire Rescue	52
Police Department	53
Planning Board News	55
Conservation Commission Report	57
Economic Development Corporation	58
Common Committee	59
Recreation Department	61
Public Library	62
<a href="http://www.whitefieldnh.org">www.whitefieldnh.org</a>	65
Forest Fire Warden and State Forest Ranger	66
Ray Burton, Councilor District One	67
Mt. Washington Regional Airport	68
Northern Gateway Regional Chamber of Commerce	73
Tri-County Community Action Program	74
North Country Council, Inc.	76
Weeks Medical Center-Home Health & Hospice Services	77
White Mountain Mental Health and Common Ground	78
Caleb Interfaith Volunteer Caregivers	80
North Country Elder Program	82
Tri-County CAP, Inc. /North Country Transit	83
North Country Home Health & Hospice Agency, Inc.	84
Ammonoosuc Community Health Services, Inc.	85
Littleton Regional Hospital	86
2007 Annual Auditor's Report	87

Front cover photo (Whitefield Bandstand) courtesy of Coös County Democrat.  
 Page 59 photo (Bandstand drawings) courtesy of Coös County Democrat.

**TOWN OFFICERS FOR THE YEAR ENDING**

**DECEMBER 31, 2007**

**(Includes elected and appointed officials & department heads)**

**Board of Selectmen**

Jay Hartnett      Wendy Hersom      Duane Hall  
(term expires 2008)   (term expires 2009)   (term expires 2010)

**Administrative Assistant**

Judith Ramsdell

**Moderator**

Harold Burns  
(term expires 2008)

**Treasurer**

Amy Hatfield  
(term expires 2008)

**Town Clerk & Deputy Tax Collector**

Stephanie Glidden  
(term expires 2010)

**Tax Collector & Deputy Town Clerk**

Joyce McGee

**Road Agent**

Stephen Kenison

**Water Superintendent**

William Thompson

**TOWN OFFICERS FOR THE YEAR ENDING**

**DECEMBER 31, 2007**

**(Includes elected and appointed officials & department heads)**

**-Continued-**

**Sewer Superintendent**

William Robinson

**Transfer Station Supervisor**

James Gooden

**Police Chief**

William Colborn

**Health Officer**

Ann Miller

**Fire/Rescue Chief**

Jay Watkins

**EMT/Administrative Assistant**

Sean P. McAlister

**Librarian**

Sandra Holz

**Recreation**

Kelly Smith

# TOWN OFFICERS FOR THE YEAR ENDING

DECEMBER 31, 2007

(Includes elected and appointed officials & department heads)

-Continued-

## Supervisors of the Checklist

Alan Ingerson	(appointed)
Colleen Malone	(term expires 2009)
Barbara Jones	(term expires 2013)

## Trustees of the Trust Funds

William Jones	(term expires 2008)
Joe Elgosin	(term expires 2009)
Catherine Burns	(term expires 2010)

## Library Trustees

Lucy Weeks	(term expires 2008)
Marion Dunham	(term expires 2008)
Kathleen Dunlap	(term expires 2009)
Eileen Alexander	(term expires 2010)
Frederick Vashaw	(term expires 2010)
Wendy Joseffy	(resigned)

## Cemetery Trustees

Joseph Elgosin	(term expires 2008)
Edgar Cormier	(term expires 2009)
Maynard L'Heureux	(term expires 2010)

## Planning Board

Ed Betz	(term expires 2009)
Scott Burns	(term expires 2010)
Frank Lombardi	(term expires 2010)
Everett Kennedy	(term expires 2010)
Duane Hall	(Board of Selectmen Representative)
John Tholl Jr.	(Alternate member)
Courtney Vashaw-Piper	(Alternate member)

**TOWN OFFICERS FOR THE YEAR ENDING**

**DECEMBER 31, 2007**

**(Includes elected and appointed officials & department heads)**

**-Continued-**

**Whitefield Conservation Commission**

Richard Mallion, Chairman

Charlie Baylies, E. Rita Chadwick

William Thompson, Marjorie Goodson

Jacqueline Comeau

**Zoning Board of Appeals**

Frank Mai, Robert Stiles

John Severance and Thomas Jackson



# TELEPHONE DIRECTORY

## EMERGENCY NUMBERS



<b>FIRE EMERGENCY</b>	<b>911</b>
<b>AMBULANCE EMERGENCY</b>	<b>911</b>
<b>POLICE EMERGENCY</b>	<b>911</b>

Selectmen's Office	837-2551
Town Clerk/Tax Collector's Office	837-9871
Police Department (non-emergency)	837-9086
Ambulance/Fire (non-emergency)	837-2655
Town Garage	837-2202
Transfer Station	837-9171
Sewer Treatment Plant	837-9571
Water Office	837-9237
Public Library	837-2030

## HOURS OPEN TO THE PUBLIC

Town Clerk/Tax Collector's Office	Mon-Fri 9:00 a.m. - 4:00 p.m. Tuesday 9:00 a.m. - 6:00 p.m.
Selectmen's Office	Mon - Fri 9:00 a.m. - 4:00 p.m.
Transfer Station	Summer Hours: Monday 12:00 p.m. - 4:00 p.m. Tuesday 8:00 a.m. - 7:00 p.m. Saturday 8:00 a.m. - 4:00 p.m.
	Winter Hours: Monday 12:00 p.m. - 4:00 p.m. Tuesday 8:00 a.m. - 5:00 p.m. Saturday 8:00 a.m. - 4:00 p.m.
Public Library Hours	Monday 9:00 a.m. - 12:00 p.m. Tues. & Thurs. 2:00 p.m. - 8:00 p.m. Saturday 10:00 a.m. - 5:00 p.m.

**TOWN OF WHITEFIELD  
2007  
ANNUAL TOWN MEETING MINUTES**

The Annual Town Meeting was held at the auditorium of the C.D. McIntyre Building on Tuesday, March 13, 2007. Harold Burns, Moderator, called the meeting to order at 7:30 p.m. The R.O.T.C. from White Mountains Regional High School presented the flags and Crystal Lang lead the salute of the flag. A moment of silence was requested in memory of Jonna Robinson, former Town Clerk/Tax Collector. Selectman Ken Jordan was honored with a plaque for serving as a Selectman since 1998. Linda Mai, Town Treasurer, was honored with a plaque for serving at Treasurer since 1988.

The Moderator read the Warrant and gave the results of the posting.

**Article 1.** The polls were opened at 8:00 o'clock in the forenoon by Moderator Harold Burns and closed at 6:00 o'clock in the afternoon. The results being as follows:

For Selectman (Three Year Term)	Duane Hall - 171 Joseph Elgosin - 144 Ken Jordan - 1
For Treasurer (One Year Term)	Amy Hatfield - 303 Linda Stock - 1 Ed Tibbets - 1
For Town Clerk (Three Year Term)	Stephanie Glidden - 311
Trustee of Trust Funds (Three Year Term)	Catherine Burns - 296 Amy Hatfield - 1
Library Trustees (Two, Three Year Terms)	Eileen Alexander - 271 Frederick Vashaw - 221 Patricia Smith - 1
Cemetery Trustee (Three Year Term)	Maynard L'Heureux - 276 Edgar Cormier - 1 Bernie Bean - 2 Duane Hall - 1 Larry Rexford - 1
Supervisor of the Checklist (Six Year Term)	Barbara Jones - 306

**Article 2.** To raise and appropriate such sums of money as may be necessary for:

**General Government:** A motion was made by Wendy Hersom to move the question. It was seconded by Jay Hartnett. The floor was opened for discussion. **A vote was taken and was in favor of the article in the amount of \$364,456.**

**Public Safety:** A motion was made by Ken Jordan to move the question. It was seconded by Wendy Hersom. The floor was opened for discussion. **A vote was taken and was in favor the article in the amount of \$498,518.**

**Airport:** A motion was made by Jay Hartnett to move the question and it was seconded by Ken Jordan. The floor was opened for discussion. A motion was made by Claire Houghton to amend the amount for Airport Operations from \$10,529 to \$9,000. The motion was seconded from the floor. The floor was opened for discussion on the amendment. Mrs. Houghton said that upon reading their report, she said she does not see the need for this increase. She said the voters need to know what actually it costs to run the airport--how much does the airport take in and how much do they spend out? Claire said she is not against the airport. She is against how it is supported through the voters of the Town of Whitefield. Why can't the Airport Commission have a fund raiser to raise some of their funds? A voice vote was taken and was in favor of the amendment. The floor was opened for discussion on the article as amended. **A vote was taken and was in favor of accepting the article as amended in the amount of \$9,000.**

**Highways/Streets & Bridges:** A motion was made by Wendy Hersom to move the question and it was seconded by Ken Jordan. The floor was opened for discussion. Jay Hartnett made a motion, which was seconded by Ken Jordan, to amend the amount of this article from \$432,495 to \$442,495, which adds \$10,000 to sidewalk maintenance. The floor was opened for discussion on the amendment. Jay explained that after receiving comments at the Public Budget Hearing on the poor conditions of the sidewalks in town and after consulting with Road Agent, Steve Kenison, the Board decided to add \$10,000 to the sidewalk maintenance line item. Ken Russell said that he doubts the state ever built those sidewalks, and they are probably in the state's right-of-way, but he doubts the state will ever fix them. A voice vote was taken and was in favor of the amendment. The floor was opened for discussion on the article as amended. **A vote was taken and was in favor of accepting the article in the amended amount of \$442,495.**

**Sanitation:** A motion was made by Ken Jordan to move the question and was seconded by Jay Hartnett. The floor was opened for discussion. **A vote was taken and was in favor of accepting the article in the amount of \$127,615.**

**Health:** A motion was made by Wendy Hersom and seconded by Jay Hartnett to move the question. The floor was opened for discussion. **A vote was taken and was in favor of accepting the article in the amount of \$1,577.**

**Welfare:** A motion was made by Ken Jordan to move the question. It was seconded by Wendy Hersom. The floor was opened for discussion. **A vote was taken and was in favor of accepting the appropriation in the amount of \$35,000.**

**Culture & Recreation:** A motion was made by Wendy Hersom to move the question. It was seconded by Ken Jordan. The floor was opened for discussion. **A vote was taken and was in favor of accepting the appropriation in the amount of \$107,937.**

**Conservation Commission:** A motion was made by Jay Hartnett to move the question. It was seconded by Ken Jordan. The floor was opened for discussion. **A vote was taken and was in favor of accepting the appropriation in the amount of \$3,400.**

**Economic Development:** A motion was made by Ken Jordan to move the question. It was seconded by Jay Hartnett. The floor was opened for discussion. **A vote was taken and was in favor of accepting the appropriation in the amount of \$5,000.**

**Debt Service:** A motion was made by Jay Hartnett to move the question. It was seconded by Wendy Hersom. The floor was opened for discussion. **A vote was taken and was in favor of accepting the appropriation in the amount of \$143,909.**

**Municipal Sewer Department:** A motion was made by Ken Jordan to move the question. It was seconded by Wendy Hersom. The floor was opened for discussion. **A vote was taken and was in favor of accepting the appropriation in the amount of \$106,935.**

**Municipal Water Department:** A motion was made by Jay Hartnett to move the question. It was seconded by Ken Jordan. The floor was opened for discussion. **A vote was in favor of accepting the appropriation in the amount of \$146,800.**

**Article 3.** To see if the Town will vote to authorize prepayment of taxes and to authorize the collector of taxes to accept such prepayment as provided in RSA 80:52-a. No taxpayer shall be allowed to prepay taxes more than two (2) years in advance of the due date of the taxes. No interest shall accrue to the taxpayer on any prepayment, nor shall any interest be paid to the taxpayer on any prepayment which is later subject to rebate or refund. This authority to remain in effect until rescinded by another vote at a Town Meeting.

A motion was made by Ken Jordan to move the question. It was seconded by Wendy Hersom. The floor was opened for discussion. **The article passed on a voice vote.**

**Article 4.** To see if the Town will vote to accept as a gift from Lois A. Stiles, Trustee of the Lois A. Stiles Revocable Trust, the parcel of land located at 28 King Square (Tax Map 103/Lot No. 51); the property is to be managed by the Selectmen as a parking lot, as provided in RSA 41:11-a, unless and until the Town votes differently.

A motion was made by Jay Hartnett to move the question. The motion was seconded by Ken Jordan. The floor was opened for discussion. Ray Gradual asked the Board how they felt about this article. Ken said the Board feels we do need the parking in the downtown. This will help alleviate some of the congestion. Alan McIntyre asked the Town if they have EPA or DES documentation that this lot is o.k. Alan said he feels the Town should have possession of that so we are not saddled with costs later on down the road. Robert Stiles said they do have documentation that this lot was cleaned up in 1986. Stan Holz said he doesn't like to see space dedicated to parking when we need more commercial space. **A voice vote was taken and was in favor of the article.**

**Article 5.** To see if the Town will vote to authorize the conveyance to the United States Forest Service of four parcels of Town-owned real estate located in the Towns of Jefferson and Carroll, Jefferson Tax Map 18/Lots 4, 5, and 7, containing approximately 150 acres and Carroll Tax Map 406/Lot 1, containing approximately 200 acres, upon such reasonable terms and conditions as may be negotiated and agreed by the Selectmen and to authorize the Selectmen to execute all documents and take all other actions reasonable and necessary to carry out the purpose of this vote.

A motion was made by Wendy Hersom to move the question. It was seconded by Jay Hartnett. The floor was opened for discussion. Mr. Richard Mallion, Chairman of the Conservation Commission, said that this land was originally the town's water shed. The land is under the control of the Water Dept. It is no longer required for water resources. Most of the land falls within the White Mountain National Forest boundaries. They are interested in purchasing it and they are only interested in purchasing it at fair market value. It will probably take 2-3 years to get this completed. They very much want it. Since the Town doesn't need the land, it is a good deal--we can get fair market value for it, and the Towns of Carroll and Jefferson don't have a problem with it. Bob asked if we are keeping the water access rights, and Mr. Mallion said we are keeping some access rights but we don't need the water anymore. It has been recently logged in a fairly responsible manner. Paul Lidstrom asked if we could lease it to them for 99 years, and the answer is no. **A voice vote was taken and was in favor of the article.**

**Article 6.** To see if the Town will vote to discontinue, subject to gates and bars, that portion of Anna Drive which is 175' and runs from a point at the northeast corner of the Brooks property (Map 102/Lot 24) and runs to the southeast corner of the Whitefield Town Garage (Map 102/Lot 21).

A motion was made Ken Jordan to move the question. The motion was seconded by Jay Hartnett. The floor was opened for discussion. Bob Stiles asked if this needed to go through the planning board so the abutters can have a say. Jay said for the process to move forward we need to vote on it tonight. Ken Russell said the Planning Board doesn't have anything to say about discontinuing roads. That is up to the Town. If the abutters have concerns, they should be here tonight. Sue Gradual asked why we want to discontinue this road. The landowner where the road goes wanted it discontinued. **A voice vote was taken and was in favor of the article.**

**Article 7.** To see if the Town will vote to establish a Capital Reserve Fund under the provisions of RSA 35:1 for the purpose of Highway Equipment Replacement and to raise and appropriate the sum of Fifteen Thousand Dollars (\$15,000) to be placed in this fund. The Selectmen recommend this appropriation. (Approximate Tax Rate Impact: 08 cents per thousand dollars of assessed value)

A motion was made by Wendy Hersom to move the question. It was seconded by Ken Jordan. The floor was opened for discussion. Ken Jordan made a motion to amend the article to read as follows:

“To see if the Town will vote to raise and appropriate the sum of Fifteen Thousand Dollars (\$15,000) to be placed in the Highway Equipment Replacement Fund created in 2001.”

The motion to amend the article was passed on a voice vote. The floor was opened for discussion on the amended article. There is currently no money in the account. **A voice vote was taken and was in favor of the amended article in the amount of \$15,000.**

**Article 8.** To see if the Town will vote to raise and appropriate the sum of Fifteen Thousand Dollars (\$15,000) to be added to the Ambulance Capital Reserve Fund created in 2004. The Selectmen recommend this appropriation. (Approximate Tax Rate Impact: 08 cents per thousand dollars of assessed value)

A motion was made by Jay Hartnett to move the question. It was seconded by Wendy Hersom. The floor was opened for discussion. **A voice vote was taken and was in favor of the article in the amount of \$15,000.**

**Article 9.** To see if the Town will vote to raise and appropriate the sum of Fifteen Thousand Dollars (\$15,000) to be placed in the Emergency Services Building Capital Reserve Fund created in 2001. The Selectmen recommend this appropriation. (Approximate Tax Rate Impact: 08 cents per thousand dollars of assessed value)

A motion was made by Jay Hartnett to move the question. It was seconded by Ken Jordan. The floor was opened for discussion. **A voice vote was taken and was in favor of the article in the amount of \$15,000.**

**Article 10.** To see if the Town will vote to establish a Capital Reserve Fund under the provisions of RSA 35:1 for the purpose of Fire Department Equipment Replacement and to raise and appropriate the sum of Fifteen Thousand Dollars (\$15,000) to be placed in this fund. The Selectmen recommend this appropriation. (Approximate Tax Rate Impact: 08 cents per thousand dollars of assessed value)

A motion was made by Wendy Hersom to move the question. It was seconded by Ken Jordan. The floor was opened for discussion. **A voice vote was taken and was in favor of the article in the amount of \$15,000.**

**Article 11.** To see if the Town will vote to establish a Capital Reserve Fund under the provisions of RSA 35:1 for the purpose of a Police Cruiser and to raise and appropriate the sum of Ten Thousand Dollars (\$10,000) to be placed in this fund. The Selectmen recommend this appropriation. (Approximate Tax Rate Impact: 05 cents per thousand dollars of assessed value)

A motion was made by Jay Hartnett to move the question. It was seconded by Ken Jordan. The floor was opened for discussion. A motion was made by Ken Jordan and seconded by Jay Hartnett to amend the article to read as follows:

“To see if the Town will vote to raise and appropriate the sum of Ten Thousand Dollars (\$10,000) to be added to the Police Cruiser Capital Reserve Fund created in 2004.”

The motion to amend passed on a voice vote. The floor was opened for discussion on the article as amended. **A voice vote was taken and was in favor of the article in the amount of \$10,000.**

**Article 12.** To see if the Town will vote to raise and appropriate the sum of Thirty-Nine Thousand Four Hundred Dollars (\$39,400) to purchase two Zoll defibrillators with mounting brackets and two year warranty for the ambulances. The Selectmen recommend this appropriation. (Approximate Tax Rate Impact: 22 cents per thousand dollars of assessed value)

A motion was made by Ken Jordan to move the question. It was seconded by Wendy Hersom. The floor was opened for discussion. **A voice vote was taken and was in favor of the article in the amount of \$39,400.**

**Article 13.** To see if the Town will vote to raise and appropriate the sum of Six Thousand Seven Hundred and Fifty Dollars (\$6,750) to do a Water Department Hydraulic Model and authorize the withdrawal of Six Thousand Seven Hundred and Fifty Dollars (\$6,750) from the Water Department Repair and Replacement Expendable General Trust Fund established in 1990 with no amount to be raised by taxation. The Selectmen recommend this appropriation.

A motion was made by Wendy Hersom and seconded by Ken Jordan to move the question. The floor was opened for discussion. **A voice vote was taken and was in favor of the article in the amount of \$6,750.**

**Article 14.** To see if the Town will vote to raise and appropriate the sum of Sixty-One Thousand Dollars (\$61,000) for the repair and rehabilitation of Spring Street. The Selectmen recommend this appropriation. (Approximate Tax Rate Impact: 34 cents per thousand dollars of assessed value)

A motion was made by Ken Jordan to move the question. It was seconded by Wendy Hersom. The floor was opened for discussion. **A voice vote was taken and was**

**in favor of the article in the amount of \$61,000.**

**Article 15.** To see if the Town will vote to raise and appropriate the sum of Seventy Thousand Dollars (\$70,000) for the closure of the town's landfill located on Hazen Road and to authorize the withdrawal of Forty-One Thousand Six Hundred and Eighty-Eight Dollars (\$41,688) plus accumulated interest from the Capital Reserve fund created for that purpose and further to authorize the Selectmen to apply for and accept grants from the New Hampshire Department of Environmental Services or any other source which may be available, to reimburse the Town for this expenditure. The balance is to come from general taxation. The Selectmen recommend this appropriation. (Approximate Tax Rate Impact: 39 cents per thousand dollars of assessed value)

A motion was made by Jay Hartnett to move the question. It was seconded by Ken Jordan. The floor was opened for discussion. A motion was made by Ken Jordan to amend the article to add "and close" after accumulated interest from. The motion was seconded by Wendy Hersom. The amended article will read as follows:

"To see if the Town will vote to raise and appropriate the sum of Seventy Thousand Dollars (\$70,000) for the closure of the town's landfill located on Hazen Road and to authorize the withdrawal of Forty-One Thousand Six Hundred and Eighty-Eight Dollars (\$41,688) plus accumulated interest from **and close** the Capital Reserve fund created for that purpose and further to authorize the Selectmen to apply for and accept grants from the New Hampshire Department of Environmental Services or any other source which may be available, to reimburse the Town for this expenditure. The balance is to come from general taxation. The Selectmen recommend this appropriation. (Approximate Tax Rate Impact: 39 cents per thousand dollars of assessed value)"

The floor was opened for discussion on the amendment. A voice vote was taken and was in favor of the amendment. The floor was opened for discussion on the amended article. **A voice vote was taken and was in favor of the amended article in the amount of \$70,000.**

**Article 16.** To see if the Town will vote to raise and appropriate the sum of Sixteen Thousand Dollars (\$16,000) to update the Town's Master Plan. The Selectmen recommend this appropriation. (Approximate Tax Rate Impact: 09 cents per thousand dollars of assessed value)

A motion was made by Wendy Hersom to move the question. It was seconded by Ken Jordan. The floor was opened for discussion. **A voice vote was taken and was in favor of the article in the amount of \$16,000.**

**Article 17.** To see if the Town will vote to raise and appropriate the sum of Ten Thousand Five Hundred and Thirty-Six Dollars (\$10,536) for the Weeks Medical Center - Home Health & Hospice Services to be used to assist in the delivery of home health and hospice services to the residents of the Town of Whitefield (By Petition) The Selectmen recommend this appropriation. (Approximate Tax Rate Impact: 05 cents per thousand



dollars of assessed value)

A motion was made by Ken Jordan and seconded by Jay Hartnett to move the question. The floor was opened for discussion. Jeff Woodburn said he has a problem with these donation agencies. Should the voters gathered here mandate a donation for the 2,000 voters who live in this community and through this process. Jeff said he feels these items should be included in the budget if they need to be in the budget. Charity begins at home and he feels the Town should fund their own operating budget before we do these charitable donations. He feels the town should send a message to these agencies. Jeff said he realizes they are all worthy causes, but people should donate on their own if they wish to donate. **A voice vote was taken and was in favor of the article in the amount of \$10,536.**

**Article 18.** To see if the Town will vote to raise and appropriate the sum of Two Thousand Eight Hundred and Sixty-Two Dollars (\$2,862) as the Town of Whitefield's contribution to the White Mountain Mental Health and Common Ground programs of Northern Human Services, serving the mental health and developmental service needs of Whitefield residents. (By Petition) The Selectmen recommend this appropriation. (Approximate Tax Rate Impact: 01 cents per thousand dollars of assessed value)

A motion was made by Ken Jordan to move the question, and it was seconded by Jay Hartnett. The floor was opened for discussion. **A voice vote was taken and was in favor of the article in the amount of \$2,862.**

**Article 19.** To see if the Town will vote to raise and appropriate the sum of Three Thousand Three Hundred Dollars (\$3,300) to help support The Caleb Interfaith Volunteer Caregivers, that serves the needs of elderly and disabled people in the community. (By Petition) The Selectmen recommend this appropriation. (Approximate Tax Rate Impact: 01 cents per thousand dollars of assessed value)

A motion was made by Ken Jordan to move the question and it was seconded by Jay Hartnett. The floor was opened for discussion. **A voice vote was taken and was in favor of the article in the amount of \$3,300.**

**Article 20.** To see if the Town will vote to raise and appropriate the sum of Two Thousand Eight Hundred Dollars (\$2,800) in support of the Tri-County CAP, Inc.--North Country Elderly Programs Senior Meals Program. (By Petition) The Selectmen recommend this appropriation. (Approximate Tax Rate Impact: 01 cents per thousand dollars of assessed value)

A motion was made by Ken Jordan to move the question. The motion was seconded by Wendy Hersom. The floor was opened for discussion. **A voice vote was taken and was in favor of the article in the amount of \$2,800.**

**Article 21.** To see if the Town will vote to raise and appropriate the sum of Three Thousand One Hundred Dollars (\$3,100). Of that amount, the sum of Sixteen Hundred

Dollars (\$1,600) to support the Senior Wheels Demand Response Program and the sum of One Thousand Five Hundred Dollars (\$1,500) to support the Lancaster-Whitefield-Littleton Tri-Town Public Transit Route. (By Petition) The Selectmen recommend this appropriation. (Approximate Tax Rate Impact: 01 cents per thousand dollars of assessed value)

A motion was made by Wendy Hersom to move the question. It was seconded by Jay Hartnett. The floor was opened for discussion. **A voice vote was taken and was in favor of the article in the amount of \$3,100.**

**Article 22.** To see if the Town will vote to raise and appropriate the sum of Three Thousand Sixty-Four Dollars (\$3,064) for the support of the home health care, supportive care, medical hospice and community health programs and services of North Country Home Health & Hospice Agency, Inc. in the fiscal year 2007 for the residents of Whitefield, N.H. (By Petition) The Selectmen recommend this appropriation. (Approximate Tax Rate Impact: 01 cents per thousand dollars of assessed value)

A motion was made by Ken Jordan and seconded by Jay Hartnett to move the question. The floor was opened for discussion. **A voice vote was taken and was in favor of the article in the amount of \$3,064.**

**Article 23.** To see if the Town will vote to raise and appropriate the sum of Twenty-Five Hundred Dollars (\$2,500) for Ammonoosuc Community Health Services, Inc. (ACHS), a non-profit community health center offering a network of affordable primary health services. As a Federally Qualified Health Center, ACHS receives federal funding to provide comprehensive preventive and primary health care to anyone, regardless of their insurance status or ability to pay. This represents a per capita amount of \$.76 for each town resident and will help ACHS continue to provide high quality care to our current 373 Whitefield patients, as well as reach more of those in need. (By Petition) The Selectmen recommend this appropriation. (Approximate Tax Rate Impact: .01 cents per thousand dollars of assessed value)

A motion was made by Wendy Hersom and seconded by Jay Hartnett to move the question. The floor was opened for discussion. **A voice vote was taken and was in favor of the article in the amount of \$2,500.**

**Article 24.** To see if the Town will vote to raise and appropriate the sum of One Thousand Four Hundred Dollars (\$1,400) for support of Northern Gateway Chamber of Commerce. (By Petition) The Selectmen do not recommend this appropriation. (Approximate Tax Rate Impact: less than 01 cents per thousand dollars of assessed value)

A motion was made by Jeff Woodburn and seconded from the floor to move the question. The floor was opened for discussion. Jeff Woodburn asked the Selectmen why they supported all the other articles and not this one. Ken Jordan said he personally has not seen a benefit or direct result from this contribution. **A voice vote was taken and the**

**article was defeated.**

**Article 25.** To see if the Town will allow the Selectmen to take over the maintenance of Lupine Lane, which is off of Rte. 116 (a/k/a Jefferson Road). This non-paved road is 600 feet in length and terminates in a cul-de-sac. It is built to State/Town standards and currently serves four property owners. (By Petition)

A motion was made by Ken Jordan and seconded by Lucy Weeks to move the question. The floor was opened to discussion. A motion was made by Lucy Weeks and seconded by Ken Jordan to amend the article to read as follows:

“To see if the Town will allow the Selectmen to accept as a Class V town highway Lupine Lane, which is off of Route 116 (a/k/a Jefferson Road). This non-paved road is 600 feet in length and terminates in a cul-de-sac. It is built to State/Town standards and currently serves four property owners.”

The floor was opened for discussion on the amendment. A voice vote approved the amendment. The floor was opened for discussion on the article as amended. Lucy Weeks and Carol Corvi, residents of the road both spoke in support of the article. Steve Kenison, Road Agent, said he did not have any information on the road nor had he inspected the road. Stan Holz said that he has questions on this article--what would we be getting in to if we accepted the road? Ken Russell said he feels it would be wise for the Selectmen to adopt a procedure that these requests be submitted in the fall before frost set in and the Road Agent and town would have opportunity to inspect these roads. Steve Kenison said the Planning Board has adopted a set of road specifications, but it is these existing roads that we don't know about. Ed Betz said he has seen situations where the town meeting can approve the article based upon a successful inspection by the Road Agent and approval of the Selectmen. Carol Corvi made a motion, which was seconded from the floor to amend the article to read as follows:

“To see if the Town will allow the Selectmen to accept as a Class V Town Highway Lupine Lane which is off of Route 116 (a/k/a Jefferson Road) subject to inspection by the Road Agent and approved by the Board of Selectmen.”

The floor was opened for discussion on the amendment. A voice vote was taken and the amendment failed.

The floor was opened for discussion on the original amendment. **A voice vote was taken and the article as amended was defeated.**

**Article 26.** To see if the Town will go on record in support of effective actions by the President and the Congress to address the issue of climate change which is increasingly harmful to the environment and economy of New Hampshire and to the future well being of the people of Whitefield.

These actions include:

1. Establishment of a national program requiring reductions of U.S. greenhouse gas Emissions while protecting the U.S. economy.
2. Creation of a major national research initiative to foster rapid development of sustainable energy technologies thereby stimulating new jobs and investment.

In addition, the Town of Whitefield encourages New Hampshire citizens to work for emission reductions within their communities, and we ask our Selectmen to consider the appointment of a voluntary energy committee to recommend local steps to save energy and reduce emissions.

The record of the vote on this article shall be transmitted to the New Hampshire Congressional Delegation, to the President of the United States, and to declared candidates for those Offices. (By Petition)

A motion was made and seconded from the floor to move the question. The floor was opened for discussion. **A voice vote was taken and was in favor of the article.**

**Article 27.** Resolved: That the residents of Whitefield consider the town to be a place where people can sit on the Common, relax on their porches, and walk through the town in peace without irritating, obtrusive and unlawful noise created by loud motor vehicles. It is further resolved that town officials and residents will do everything in their power to create a hospitable, quiet environment. (By Petition)

A motion was made and seconded from the floor to move the question. The floor was opened for discussion. **A voice vote was taken and was in favor of the article.**

**Article 28.** To transact any other business that may lawfully come before said meeting.

As there was no other business to transact, the meeting adjourned at 9:20 p.m.

I, hereby, certify that the above return of the Annual Town Meeting of March 13, 2007 is true and correct to the best of my knowledge and belief.



Stephanie Glidden, Town Clerk  
Whitefield, NH 03598

**DEPARTMENT OF REVENUE ADMINISTRATION**  
**Municipal Services Division**  
**2007 Tax Rate Calculation**

**TOWN/CITY: WHITEFIELD**

*Barbara J. Robinson*  
11/6/07

Gross Appropriations	2,283,954
Less: Revenues	1,447,617
Less: Shared Revenues	16,372
Add: Overlay	14,894
War Service Credits	42,900

Net Town Appropriation	877,759
Special Adjustment	0

Approved Town/City Tax Effort	877,759	<b>TOWN RATE</b> 4.91
-------------------------------	---------	--------------------------

**SCHOOL PORTION**

Net Local School Budget (Gross Approp. - Revenue)	0	23% of Total Rate
Regional School Apportionment	3,810,840	
Less: Adequate Education Grant	(1,527,551)	

State Education Taxes	(401,332)	<b>LOCAL SCHOOL RATE</b> 10.52
Approved School(s) Tax Effort	1,881,957	

49% of Total Rate

**STATE EDUCATION TAXES**

Equalized Valuation(no utilities) x	\$2.24	401,332	<b>STATE SCHOOL RATE</b> 2.41
179,166,140			
Divide by Local Assessed Valuation (no utilities)			11% of Total Rate
166,725,860			
Excess State Education Taxes to be Remitted to State			
Pay to State →	0		

**COUNTY PORTION**

Due to County	653,536	<b>COUNTY RATE</b> 3.64 17% of
Less: Shared Revenues	(2,877)	
Approved County Tax Effort	650,659	<b>TOTAL RATE</b> 21.48

Total Rate

Total Property Taxes Assessed	3,811,707
Less: War Service Credits	(42,900)
Add: Village District Commitment(s)	0
<b>Total Property Tax Commitment</b>	<b>3,768,807</b>

**PROOF OF RATE**

Net Assessed Valuation	Tax Rate	Assessment
State Education Tax (no utilities)	2.41	401,332
All Other Taxes	19.07	3,410,375
		3,811,707

**TRC#**  
**184**

**TRC#**  
**184**

# TOWN OF WHITEFIELD 2007 SUMMARY OF VALUATION

**Value of Land Only:**

Current Use	\$ 1,644,650
Residential	\$ 50,642,290
Commercial/Industrial	<u>\$ 4,313,970</u>
<b>Total Value of Taxable Land</b>	<b>\$ 56,600,910</b>

**Value of Buildings Only:**

Residential	\$ 88,072,530
Manufactured Housing	\$ 3,102,620
Commercial/Industrial	<u>\$ 20,103,330</u>
<b>Total Value of Taxable Buildings</b>	<b>\$111,278,480</b>

**Total Value of Public Utilities** \$ 12,083,631

<b>Total Valuation Before Exemptions</b>	<b>\$ 179,963,021</b>
Less: Value of Elderly Exemptions	(\$ 1,138,530)
Less: Value of Blind Exemptions	<u>(\$ 15,000)</u>

**Net Valuation on which the Tax Rate for  
Town, County, & Local Education Tax  
is computed.** \$ 178,809,491

Less: Public Utilities (\$ 12,083,631)

**Net Valuation on which the Tax Rate for  
State Education is computed.** \$ 166,725,860

# TOWN OF WHITEFIELD COMPARISON OF TAX RATES

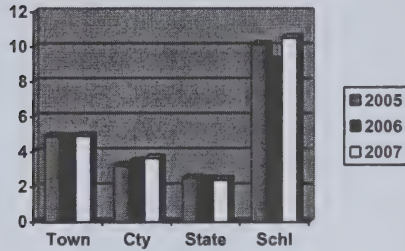

YEAR	TOWN RATE	COUNTY RATE	STATE SCHOOL	LOCAL SCHOOL	TOTAL TAX RATE
2007	4.91	3.64	2.41	10.52	21.48
2006	4.84	3.44	2.44	9.21	19.93
2005	4.88	3.21	2.50	10.13	20.72
2004	6.95	3.73	2.50	9.79	22.97
2003	11.39	5.00	4.60	14.90	35.89
2002	10.93	3.98	5.99	10.00	30.90
2001	9.47	3.72	7.23	9.56	29.98
2000	5.73	3.94	7.20	10.47	27.34
1999	4.87	4.14	7.37	7.92	24.30
1998	5.34	4.06		21.40	30.80
1997	5.77	3.61		20.03	29.41
1996	6.25	3.22		20.31	29.78
1995	8.03	3.14		18.44	29.61
1994	8.18	3.15		19.12	30.45
1993	6.77	3.48		17.72	27.97
1992	14.12	6.94		34.89	55.95
1991	9.22	5.67		38.59	53.48

# SEWER DEPARTMENT

(un-audited)

PURPOSE OF APPROPRIATION	2007 APPROP.	2007 ACTUAL	2008 PROPOSED
Operator's Wages	\$ 25,100.00	\$ 25,311.00	\$ 26,000.00
Asst. Operator's Wages	\$ 2,000.00	\$ 2,004.66	\$ 2,000.00
Collector's Wages	\$ 4,200.00	\$ 4,101.75	\$ 4,500.00
Labor	\$ 4,000.00	\$ 4,147.50	\$ 4,000.00
FICA	\$ 2,200.00	\$ 2,205.18	\$ 2,300.00
Medicare	\$ 525.00	\$ 515.55	\$ 550.00
Unemployment	\$ 150.00	\$ 96.02	\$ 150.00
Worker's Comp.	\$ 450.00	\$ 835.13	\$ 800.00
Telephone	\$ 1,200.00	\$ 915.06	\$ 1,200.00
Electricity	\$ 25,000.00	\$ 28,170.78	\$ 25,000.00
Heat	\$ 1,000.00	\$ 694.88	\$ 1,000.00
Water Rents	\$ 800.00	\$ 330.00	\$ 400.00
Repairs/Supplies	\$ 10,864.00	\$ 9,950.96	\$ 12,500.00
Office Supplies	\$ 500.00	\$ 96.33	\$ 400.00
Fuel/Gas/Oil	\$ 1,500.00	\$ 1,797.76	\$ 1,600.00
Misc.	\$ 2,000.00	\$ 8,331.16	\$ 2,000.00
Ref./Reimb.	\$ 100.00	\$ -	\$ -
Capacity Analysis Engin.	\$ -	\$ -	\$ 20,000.00
Equipment	\$ 6,846.00	\$ 9,262.36	\$ 4,035.00
Testing	\$ 18,500.00	\$ 18,236.32	\$ 18,500.00
<b>TOTAL SEWER EXPENDITURES</b>	<b>\$106,935.00</b>	<b>\$ 117,002.40</b>	<b>\$ 126,935.00</b>

## REVENUE

Sewer Usage	\$ 99,535.00	\$ 102,748.16	\$ 119,535.00
Hook-Ups	\$ 1,000.00	\$ 1,000.00	\$ 1,000.00
Job Works	\$ 800.00	\$ 825.00	\$ 800.00
Reimbursement Uncollected	\$ 200.00	\$ 225.00	\$ 200.00
Investment Account Interest	\$ 4,000.00	\$ 4,117.09	\$ 4,000.00
Interest & Costs	\$ 1,400.00	\$ 1,445.30	\$ 1,400.00
<b>TOTAL SEWER REVENUE</b>	<b>\$106,935.00</b>	<b>\$ 110,360.55</b>	<b>\$ 126,935.00</b>

## FINANCIAL STATEMENT

<b>CASH ON HAND AS OF 01/01/06</b>	<b>\$ 154,506.68</b>
EXPENDITURES 2006-December	\$ (8,926.90)
2007 REVENUE	\$ 110,360.55
EXPENDITURES 2007-Less Dec.07' \$11,867.71+ \$257.04 as not processed	\$(105,391.73)
<b>CASH ON HAND AS OF 12/31/07</b>	<b>\$ 150,548.60</b>
MBIA PDIP Account-12/31/07	\$ 92,961.11
Laconia Checking Account - 12/31/07	\$ 57,587.49
	<b>\$ 150,548.60</b>

Respectfully submitted by:

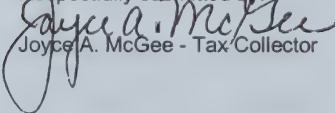
  
 Joyce A. McGee - Tax Collector



# WATER DEPARTMENT

(un-audited)

PURPOSE OF APPROPRIATION	2007 APPROP.	2007 ACTUAL	2008 PROPOSED
Operator's Wage	\$ 39,700.00	\$ 38,896.36	\$ 41,000.00
Collector's Wages	\$ 4,200.00	\$ 4,101.75	\$ 4,500.00
Labor	\$ 10,000.00	\$ 5,685.00	\$ 7,000.00
Health Insurance	\$ 10,500.00	\$ 10,409.88	\$ 11,625.00
Life/Disability	\$ 500.00	\$ 477.12	\$ 500.00
FICA	\$ 3,400.00	\$ 2,861.93	\$ 3,400.00
Medicare	\$ 800.00	\$ 669.42	\$ 800.00
Retirement	\$ 2,600.00	\$ 3,197.10	\$ 3,600.00
Unemployment	\$ 900.00	\$ 131.45	\$ 900.00
Worker's Comp.	\$ 1,500.00	\$ 1,284.51	\$ 1,500.00
Telephone	\$ 5,500.00	\$ 5,512.18	\$ 5,500.00
Equip. Hire	\$ 1,000.00	\$ 1,477.50	\$ 500.00
Outside Labor	\$ 1,000.00	\$ 1,261.00	\$ 1,000.00
Training	\$ 500.00	\$ 547.50	\$ 1,000.00
Electricity	\$ 36,000.00	\$ 37,181.81	\$ 40,000.00
Heat	\$ 1,000.00	\$ 1,171.37	\$ 1,500.00
Repairs/Supplies	\$ 13,000.00	\$ 14,193.61	\$ 5,275.00
Office Supplies	\$ 1,000.00	\$ 683.63	\$ 1,000.00
Gas/Oil	\$ 1,500.00	\$ 1,546.27	\$ 2,000.00
Mileage/Travel/Meals	\$ 500.00	\$ 275.00	\$ 500.00
Ref./Reimb./Overpayment	\$ 700.00	\$ 776.37	\$ 700.00
Taxes	\$ 3,000.00	\$ 5,417.00	\$ 3,000.00
Water Testing	\$ 2,500.00	\$ 2,503.80	\$ 3,500.00
Corrosion Control	\$ 3,500.00	\$ 3,171.00	\$ 4,000.00
Water Main Rplcmt.	\$ -	\$ 4,531.64	\$ -
Misc.	\$ 500.00	\$ 355.00	\$ 1,000.00
Computer	\$ 1,500.00	\$ 1,950.00	\$ 1,500.00
Well Pump Test	\$ -	\$ -	\$ -
<b>TOTAL WATER EXPENDITURE</b>	<b>\$ 146,800.00</b>	<b>\$ 150,269.20</b>	<b>\$ 146,800.00</b>
<b>REVENUE</b>			
Water Rents	\$ 135,670.00	\$ 143,713.34	\$ 135,500.00
Job Works	\$ 4,200.00	\$ 4,200.08	\$ 4,200.00
Reimbursements	\$ 630.00	\$ 630.00	\$ 600.00
Investment Account Interest	\$ 2,000.00	\$ 2,026.29	\$ 2,000.00
Hook-Ups	\$ 2,000.00	\$ 7,000.00	\$ 2,000.00
Donations	\$ 500.00	\$ 500.00	\$ 500.00
Interest & Costs	\$ 1,800.00	\$ 2,318.30	\$ 2,000.00
<b>TOTAL WATER REVENUE</b>	<b>\$ 146,800.00</b>	<b>\$ 160,388.01</b>	<b>\$ 146,800.00</b>

**FINANCIAL STATEMENT**

<b>CASH ON HAND AS OF 1/1/06</b>	<b>\$ 92,892.48</b>
EXPENDITURES 2006 - December	\$ (14,992.30)
REVENUE 2007	\$ 160,388.01
EXPENDITURES 2007-Less Dec. 07' \$19,332.28+\$364.91 as not processed	<u>\$(131,301.83)</u>
<b>CASH ON HAND AS OF 12/31/07</b>	<b><u>\$ 106,986.36</u></b>
MBIA PDIP Account-12/31/07	\$ 42,148.14
Laconia Checking Account - 12/31/07	<u>\$ 64,838.22</u>
	<b><u>\$ 106,986.36</u></b>

Respectfully submitted by:

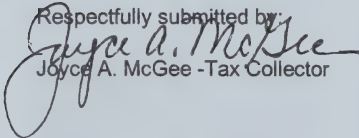
  
Joyce A. McGee -Tax Collector

## 2007 INVENTORY OF TOWN PROPERTY

Map/Lot	Description	Land	Building	Total Value
233/007	Airport House/20 Airport Road	47,610	86,610	134,220
221/016	.27 acres-Jefferson Road/ Partridge Lane	11,550		11,550
102/036	.20 acres-42 Brown Street	14,500		14,500
102/021	3.9 acres-Town Garage 13 Anna Drive	46,840	137,400	184,240
103/001	.99 acres-Town Hall & Library	40,000	406,800	446,800
228/015	11.5 acres -Treatment Plant	48,230	1,015,650	1,063,880
102/004	.44 acres -Pump Station	14,980	1,860	16,840
233/009	8.20 acres – 238 Colby Road	29,810		29,810
103/040	1.35 acres – Fire Station 48 Littleton Road	41,040	154,000	195,040
234/001	179.8 acres -Airport & Office Building	272,450	544,020	816,470
102/008	.03 acres -Brown Street	50		50
102/010	.08 acres -Brown Street	120		120
103/072	.04 acres -Laurel Street	60		60
102/025	1.80 acres -Brown Street	27,700		27,700
102/056	7.2 acres -Recreation Field Highland Street	37,450	10,820	48,270
103/003	.04 acres -Corner of Lancaster/ Jefferson Road	1,750		1,750
103/109	0.090 acres -Highland Street	9,200		9,200
102/069	.04 acres -Pine Street	60		60
103/090	8.60 acres –Laurel St. Ext.	35,880		35,880
214/006	31 acres -Water Tank 73 Bray Hill Road	53,550	3,900	57,450

## 2007 INVENTORY OF TOWN PROPERTY

Map/Lot	Description	Land	Building	Total Value
228/014	2.50 acres -Parker Road	47,250	42,600	89,850
228/011	0.190 acres -Parker Road	7,600		7,600
225/010	21.0 acres -Transfer Station 187 Hazen Road	62,400	36,140	98,540
234/006	14.33 acres -L/O Industrial Park	45,500		45,500
238/001	.61 acres -Well Site Off Colby Road	920	1,100	2,020
233/032	13.0 acres -Water Tank Colby Road	34,650		34,650
231/011	3.88 acres -Reservoir Twin Mtn. Road	34,320		34,320
231/009	.68 acres -Twin Mt. Road	23,600		23,600
230/070	9.67 acres -Water Pump House Littleton Road	46,350	2,015,700	2,062,050
103/143	.435 acres -Elm Street	31,660	14,000	45,660
233/005	15.0 acres -Airport Road/Marsh	14,650		14,650
234/004	105.65 acres -Airport Road	124,640		124,640
103/101	.23 acres -38 Brown Street	16,000		16,000
103/157	1.52 acres -Littleton Road	51,410		51,410
103/053	.48 acres -King Square/Gazebo	33,140	3,400	36,540
103/042	7.22 acres -Ballfield Littleton Road	49,140	6,600	55,740
103/052	.06 acres -King Square	2,750		2,750

# 2007 TOWN CLERK'S REPORT

## FOR YEAR ENDING DECEMBER 31, 2007

(UN-AUDITED)

### 2007 FEES COLLECTED

MOTOR VEHICLES PERMITS	\$332,103.16
MOTOR VEHICLE TRANSACTION FEE	\$7,537.50
TITLE FEES	\$902.00
MARRIAGES	\$1,035.00
DOGS	\$4,129.00
DOG CIVIL FORFEITURE FEE	\$25.00
UCC	\$945.00
OHRV	\$7,084.00
BOAT LICENCES	\$1,106.28
VITAL STATISTICS	\$1,532.00
MICELLANEOUS FEES	<u>\$2,596.97</u>
GRAND TOTAL	\$358,995.91

RESPECTFULLY SUBMITTED,



STEPHANIE GLIDDEN, TOWN CLERK

# DOG LICENSING REMINDER

## REQUIREMENTS

Each dog over three months old must be registered by its owner or keeper prior to April 30<sup>th</sup> each year. The Town Clerk shall provide to the registrant a tag, which shall be worn by the registered dog. The tag shall carry the name of the town, the year issued for the license, and the registered number of the dog. These tags shall be furnished by the Town Clerk at the expense of the City or Town. No license shall be issued by the Town Clerk until a certificate of rabies is produced by the person registering the dog.

## FEES

1. For each altered dog, the fee will be \$6.50 (beginning in 1994)
2. The fee for each regular dog will be \$9.00 (beginning in 1994)
3. The Town Clerk must be satisfied with the certificate presented by the person registering the dog which attests that the dog has been altered.
4. License fee for a puppy (older than 3 months but younger than 7 months) is \$6.50. After the initial license year, the dog owner will need to supply proof of spaying/neutering in order to maintain the reduced fee.

## EXEMPTIONS

1. For dog owners 65 or over, the fee shall be \$2.00 for the first dog, but the regular fee shall apply for any additional dog.
2. No fee shall be required for the registration and licensing of a seeing-eye dog used by a blind person, or a hearing dog used by a deaf person.

## GROUP LICENSES

1. Any person who keeps five or more dogs shall by April 30<sup>th</sup> each year pay the required fee and obtain a license authorizing him or her to keep the dogs on the premises described in the license. The Town Clerk may not deny a group license to any person who complies with the requirement.
2. Group license fees are \$20.00 for five or more dogs.

**There Will Be A Rabies Clinic On Saturday, April 19, 2008**  
**At The Whitefield Fire Department From 1 p.m. – 3 p.m.**



**2007 Vital Statistics**  
**Marriages registered in the**  
**Town of Whitefield, New Hampshire**

<b>Date of Marriage</b>	<b>Name and Surname of Groom and Bride</b>	<b>Residence of Each at Time of Marriage</b>
01/27/2007	Richard A. McNelly Jennifer L. Hopps	Whitefield, NH Whitefield, NH
02/14/2007	Ronald J. Wooley Karen H. Keller	Whitefield, NH Whitefield, NH
03/18/2007	Alfred D. Bragdon Christina M. Crawford	Whitefield, NH Whitefield, NH
07/03/2007	Kevin J. Ainsworth Lisa A. Chandler	Whitefield, NH Whitefield, NH
07/07/2007	Christopher J. Luck Linda M. Murphy	Whitefield, NH Whitefield, NH
08/04/2007	Matthew O. Gordon Karen M. Murray	Whitefield, NH Whitefield, NH
09/16/2007	Terry L. Hines Beverly H. Desjardins	Whitefield, NH Whitefield, NH
10/06/2007	Douglas E. Norvell Jennifer D. Sawyer	Whitefield, NH East Conway, NH
10/13/2007	Peter Duguay Rebecca Wellington	Whitefield, NH Whitefield, NH

**2007 Vital Statistics**  
**Marriages registered in the**  
**Town of Whitefield, New Hampshire**

**-Continued-**

<b>Date of Marriage</b>	<b>Name and Surname of Groom and Bride</b>	<b>Residence of Each at Time of Marriage</b>
12/23/2007	Philip L. Beaulieu Elizabeth A. Grochowski	Whitefield, NH Whitefield, NH
12/30/2007	Stephen M. Comeau Pamela A. Woodburn	Whitefield, NH Whitefield, NH
12/30/2007	Allen R. Pihl Laura R. Smith	Whitefield, NH Whitefield, NH



**2007 Vital Statistics**  
**Births Registered in the Town of Whitefield, New Hampshire**  
**For the Year Ending December 31, 2007**

<u>Date of Birth</u>	<u>Place of Birth</u>	<u>Name of Child</u>	<u>Name of Father</u>	<u>Name of Mother</u>
02/22/2007	Lancaster, NH	Connor Maurice Mears	Philip Mears	Stephanie Cormier-Mears
02/27/2007	Lancaster, NH	Samuel Luis Waterman	Benjamin Waterman	Stephanie Waterman
03/09/2007	Lancaster, NH	Ryan Max Mauzy	Thomas Mauzy	Tanja Mauzy
03/11/2007	Littleton, NH	Brianna Marie Barron	Robert Barron	Nicole Livingston
04/09/2007	Lancaster, NH	Jack Kenneth Fuller	Brian Fuller	Shannon Fuller
05/01/2007	Lancaster, NH	Ellyn Kay Dawn Gault	Kevin Gault	Kris-Ann Gault
05/10/2007	Littleton, NH	Skye Lynn Warren	Adam Warren	Karen Warren
06/14/2007	Littleton, NH	Sean Anthony Donovan	Ryan Donovan	Christina Harriman
06/28/2007	Littleton, NH	Robert Andrew Deamicis	Robert Deamicis	Whitney Endres
07/04/2007	Littleton, NH	Bridget Baker Wilson	Matthew Wilson	Martha Wilson

**2007 Vital Statistics**  
**Births Registered in the Town of Whitefield, New Hampshire**  
**For the Year Ending December 31, 2007**

-continued-

<u>Date of Birth</u>	<u>Place of Birth</u>	<u>Name of Child</u>	<u>Name of Father</u>	<u>Name of Mother</u>
08/06/2007	Littleton, NH	Delaney Elizabeth Dube	Gregory Dube	Jessica Dube
09/15/2007	Manchester, NH	Leland Joseph Gooden	David Gooden	Diane Gooden
10/19/2007	Berlin, NH	Yolanda Josefina Taveras	Edward Taveras	Jessica Taveras
11/14/2007	Lebanon, NH	Kadyn Anthony Santana	Alberto Santana	Katie Cochran
11/20/2007	Littleton, NH	Benjamin Robert Willey	Theodore Willey	Becky Willey
12/12/2007	Littleton, NH	Lillian Mae Ingerson	Benjamin Ingerson	Koryn Ingerson
12/13/2007	Lancaster, NH	Alexz Lynn Bragdon	Alfred Bragdon	Christina Bragdon

## 2007 Vital Statistics

### Deaths Registered in the Town of Whitefield, New Hampshire For the Year Ending December 31, 2007

<u>Date of Death</u>	<u>Place of Death</u>	<u>Decedent's Name</u>	<u>Father's Name</u>	<u>Mother's Maiden Name</u>
01/09/2007	Lancaster, NH	Ernestine Blanchard	Ernest Cass	Laura Wheeler
01/12/2007	Littleton, NH	Gerarda Shosa	Donald Pilotte	Louise Fountain
01/22/2007	Lancaster, NH	Catherine Dobson	Charles Drake	Juanita Macdonald
02/04/2007	Lancaster, NH	Charles Merrow	Charles Merrow	Amelia Malasky
02/05/2007	Lebanon, NH	Marjorie Machell	Alfred Englert	Janet Jordan
02/12/2007	Whitefield, NH	Marie Garrion	Rodney Garrion	Frances Unknown
02/15/2007	Whitefield, NH	Viola Caruso	Peter Mita	Anna Pelletier
03/07/2007	Lancaster, NH	Jonna Robinson	John Romanoke	Anna Zanowiak
03/09/2007	Littleton, NH	Ruth Harris	William Harris	Lydia Priest
03/23/2007	Whitefield, NH	Katharine Stockwell	Frank Ramsdell	Laura Grant

## 2007 Vital Statistics

### Deaths Registered in the Town of Whitefield, New Hampshire For the Year Ending December 31, 2007 -continued-

<u>Date of Death</u>	<u>Place of Death</u>	<u>Decedent's Name</u>	<u>Father's Name</u>	<u>Mother's Maiden Name</u>
04/16/2007	Littleton, NH	Eleanor Johnson	Richard Stimpson	Ruth Lyon
04/19/2007	Lancaster, NH	Lyle Grimes	Gerald Grimes	Mildred Jones
05/12/2007	Hanover, NH	Elmer Black Jr.	Elmer Black	Anna Champagne
05/23/2007	Whitefield, NH	Doris Davis	William Perkins	Carolyn Morey
5/30/2007	Littleton, NH	Frank Porfido Sr.	Emilio Porfido	Carmela Potito
06/05/2007	Lancaster, NH	Peter Beccard	Alphonse Beccard	Kate Hechler
06/22/2007	Littleton, NH	Frances Gentry	Henry Deitrickson	Florence Hall
06/28/2007	Whitefield, NH	Willard Ramsdell	Frank Ramsdell	Lura Grant
07/01/2007	Lebanon, NH	Alice McGee	Harry Nash	Dorothy Williams
07/06/2007	Whitefield, NH	Margaret Whitcomb	Foster Turner	Mary Tyler
08/15/2007	Littleton, NH	Dayr Tierney	Nelson Ward	Cora Hooker

## 2007 Vital Statistics

### Deaths Registered in the Town of Whitefield, New Hampshire For the Year Ending December 31, 2007 -continued-

<u>Date of Death</u>	<u>Place of Death</u>	<u>Decedent's Name</u>	<u>Father's Name</u>	<u>Mother's Maiden Name</u>
08/20/2007	Whitefield, NH	Carl Baker	Sidney Baker	Viola Cysco
09/07/2007	Whitefield, NH	Philip Rowell	George Philbrick	Christine Boyd
09/19/2007	Lancaster, NH	Maureen Nutting	Chester Barnett	Alice Rexford
10/05/2007	Whitefield, NH	Harry Miller	Henry Miller	Bessie Enman
10/09/2007	Whitefield, NH	Clarence Brown	Elwin Brown	Lyndall Call
11/06/2007	Whitefield, NH	David Ruggles	Herbert Ruggles	Lillian Emery
11/10/2007	Lancaster, NH	Virginia Ward	Charles Hodge	Hazel Barrows
12/15/2007	Lancaster, NH	Earl Woods	James Woods	Marion Woodward
12/24/2007	Whitefield, NH	Bernard Kimball Sr.	David Kimball	Jennie Townsend
12/28/2007	Littleton, NH	Malcolm Lucia	Warren Lucia	Jennie Lamb

**2007 TAX COLLECTOR'S REPORT  
YEAR ENDING DECEMBER 31, 2007**

(un-audited)

	2007 Levy	2006 Levy	2005 Levy
<b>Uncollected Taxes</b>			
Property Taxes		\$ 331,675.49	
Land Use Change			
Yield Taxes		\$ 53.66	
Utilities		\$ 35,499.00	
Other Charges		\$ 41.25	
<b>Taxes Committed</b>			
Property Taxes	\$ 3,786,876.95		
Land Use Change Tax	\$ 12,950.00		
Yield Taxes	\$ 7,519.87		
Utilities	\$ 269,413.58		
Gravel Tax	\$ 298.40		
Other Charges	\$ 2,942.13	\$ 686.20	
<b>Overpayment</b>			
Property Taxes	\$ 3,567.09	\$ 291.00	
Utilities	\$ 698.90	\$ 77.47	
2008 - Prepayment	\$ 64.91		
<b>Collect Int. - Late Taxes</b>	\$ 4,484.83	\$ 18,892.95	
<b>Costs Before Lien</b>		\$ 2,930.00	
<b>TOTAL DEBITS</b>	<u>\$ 4,088,816.66</u>	<u>\$ 390,147.02</u>	
<b>Remitted to Treasurer</b>			
Property Taxes	\$ 3,406,437.87	\$ 218,281.46	
2008 Taxes	\$ 64.91		
Land Use Change	\$ 12,950.00		
Yield Taxes	\$ 7,493.67	\$ 53.66	
Utilities	\$ 221,694.23	\$ 22,805.30	
Gravel Tax	\$ 298.40		
Interest	\$ 4,484.83	\$ 10,309.65	
Conversion to Lien		\$ 137,722.00	
Other Charges	\$ 2,422.13	\$ 727.45	
<b>Abatements Made</b>			
Property Taxes	\$ 8,923.55		
Yield Tax	\$ 26.20		
Utilities	\$ 2,971.03	\$ 247.50	
Bad Check	\$ 25.00		
<b>Uncollected Taxes - End of Year</b>			
Property Taxes	\$ 375,082.62		
Yield Tax			
Utilities	\$ 45,447.22		
Other Charges	\$ 495.00		
<b>TOTAL CREDITS</b>	<u>\$ 4,088,816.66</u>	<u>\$ 390,147.02</u>	

**2007 TAX COLLECTOR'S REPORT**  
**YEAR ENDING DECEMBER 31, 2007**  
(un-audited)

**Continued**

<b>Liens Executed</b>	2006 Levy	2005 Levy	2004 & Prior Levy
Unredeemed Liens - Beg. of Year		\$ 69,165.16	\$ 46,932.85
Liens Executed During Fiscal Year	\$ 137,722.00		
Interest & Costs Collected	\$ 3,472.78	\$ 5,252.95	\$ 13,433.34
<b>TOTAL DEBITS</b>	\$ 141,194.78	\$ 74,418.11	\$ 60,366.19

<b>Remitted to Treasurer</b>	2006 Levy	2005 Levy	2004 & Prior Levy
Redemptions	\$ 44,207.36	\$ 29,138.41	\$ 42,925.94
Interest & Costs Collected	\$ 2,160.34	\$ 5,722.20	\$ 14,211.03
Abatements of Unredeemded Tax			\$ -
Unredeemded Lien Balance	\$ 94,827.08	\$ 39,557.50	\$ 3,229.22
<b>TOTAL CREDITS</b>	\$ 141,194.78	\$ 74,418.11	\$ 60,366.19

Respectfully submitted by:

*Joyce A. McGee*  
Joyce A. McGee-Tax Collector

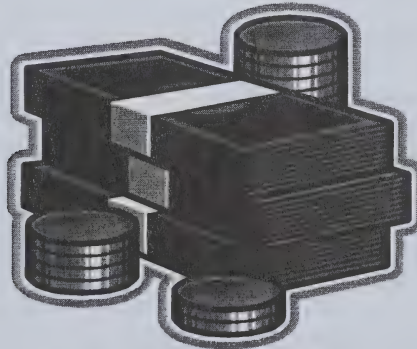

# TREASURER'S REPORT

January 1, 2007 - December 31, 2007

Balance as of January 1, 2007	\$1,028,110.81
2007 Receipts:	\$5,355,061.08
2007 Expenditures:	
White Mountains Regional School District	\$2,239,177.00
Coos County Treasurer	\$ 653,536.00
Town of Whitefield	\$2,727,456.55
Balance as of December 31, 2007:	\$ 763,002.34
Account Balances as of 12/31/2007:	
Public Deposit Investment Pool:	
General Fund	\$ 19,496.80
Water Department	\$ 42,148.14
Recreation Dept. Special Revenue Fund	\$ 57,066.98
Playground Savings Account	\$ 6.34
Sewer Treatment Plant	\$ 92,961.11
Laconia Savings Bank:	
Business Account	\$ 99,820.24
Repo. Agmt. Acct.	\$ 846,289.61
Common Improvement Fund	\$ 2,305.48
Band Concerts	\$ 10,868.96
Whitefield Economic Development	\$ 811.89
Whitefield Economic Development - C.D.	\$ 2,743.58
Bandstand Account	\$ 5,478.55
Lancaster National Bank:	
Highway Account	\$ 2.50
Hazardous Waste Equipment Account	\$ 3,210.19
Playground	\$ 17,690.71
Whitefield Little League	\$ 322.81
Dare Account	\$ 2,758.09



Reserve for Encumbrances Disbursed in 2007:	
Landfill Closure Engineering	\$2,820.00
E.M.S. Building Architect	\$1,516.89
Refunds Issued in 2007:	\$6,571.13

Grant Transactions in 2007:

Runway Extension Grant:	
Disbursed:	\$ 49,847.70

Airport Taxiway:	
Grant Funds Received:	\$ 124,802.09
Disbursed:	\$ 262,644.80

Instrument Landing System--Feasibility Study Update:	
Grant Funds Received:	\$ 10,151.31
Disbursed:	\$ 4,383.42

Telecom Grant:	
Grant Funds Received:	\$ 9,000.00
Disbursed:	\$ 9,000.00

**TOWN OF WHITEFIELD**  
**2007 STATEMENT-ESTIMATED/ACTUAL REVENUES**

(un-audited)

	2007 Budget	2007 Actual
<b><u>Revenue from Taxes:</u></b>		
Current Use Penalties	\$12,950.00	\$12,950.00
Gravel Excavation Tax	\$300.00	\$298.40
Timber Yield Tax	\$6,000.00	\$7,547.33
Payment in Lieu of Taxes:		
Highland House	\$16,000.00	\$16,000.00
Weeks Medical Center	\$4,000.00	\$10,928.46
C.D. McIntyre Apartments	\$16,000.00	\$12,700.26
Weathervane Theatre	\$2,000.00	\$800.00
Fish & Wildlife Service	\$3,000.00	\$982.00
Littleton Regional Hospital	\$4,000.00	\$2,650.91
Interest & Penalties on Taxes	\$45,000.00	\$45,323.95
<b><u>Revenue from Licenses, Permits &amp; Fees:</u></b>		
Motor Vehicle Fees	\$325,000.00	\$332,103.16
Dog Licenses	\$4,000.00	\$4,154.00
Fees	\$4,000.00	\$20,171.75
Marriage Licenses/VS State Fees	\$2,000.00	\$2,567.00
<b><u>Revenue from Other Governments:</u></b>		
Shared Revenue	\$16,694.00	\$55,236.38
Meals & Room Tax Distribution	\$89,354.00	\$89,354.21
Highway Block Grant	\$61,732.00	\$61,732.00
Railroad Tax	\$0.00	\$1,387.25
Route 3 Sewer Grant	\$10,770.00	\$10,770.00
<b><u>Revenue from Departments</u></b>		
Police Department		
Court Fines	\$5,000.00	\$266.67
Ordinance Fines	\$1,000.00	\$300.00
Parking Tickets	\$1,000.00	\$355.00
Witness Fees	\$1,000.00	\$120.00
Special Duty	\$30,000.00	\$5,925.28
Report Copies	\$1,000.00	\$625.00
Miscellaneous	\$1,000.00	\$3,065.59
SRO Reimbursement	\$0.00	\$16,794.87
Ambulance Fees	\$145,000.00	\$142,881.39
Ambulance Apprpr./Town of Dalton	\$5,000.00	\$4,680.00
Planning Board	\$3,000.00	\$1,475.77
Fire Department	\$4,000.00	\$1,114.32
Highway Department	\$3,000.00	\$1,847.00
Transfer Station:		
Sale of Recyclables	\$5,000.00	\$14,295.70
Landfill Fees	\$10,000.00	\$22,746.95
Pay-Per-Bag Income	\$20,000.00	\$31,600.00
Miscellaneous	\$0.00	\$125.39
Town Office Income	\$0.00	\$8.30
Recreation Department	\$0.00	\$159.00
<b><u>Revenue from Miscellaneous:</u></b>		
Welfare Reimbursements	\$0.00	\$1,106.42
Interest on Deposits	\$20,000.00	\$23,061.41
Sale of Town Property	\$0.00	\$0.00
Gas Tax Refund	\$1,000.00	\$2,808.59
Airport Fuel Farm Reimbursement	\$5,000.00	\$4,682.00
Miscellaneous	\$9,000.00	\$220.00
From Capital Reserve Accounts	\$43,332.00	\$43,331.78
FEMA April Flood Relief	\$0.00	\$11,075.99
From Water Dept. Rep&Rplcmt Fund	\$6,750.00	\$5,700.00
<b>TOTAL REVENUES</b>	<b>\$942,882.00</b>	<b>\$1,028,029.48</b>

# TOWN OF WHITEFIELD

## 2007 DETAILED STATEMENT OF PAYMENTS

	2007 <i>Budgeted</i>	2007 <i>Expended</i>	<i>(Over)/Under Budget</i>
<b>GENERAL GOVERNMENT</b>			
<b>EXECUTIVE</b>			
Selectmen Salaries	4,500.00	4,500.00	
SS/FICA	280.00	279.00	1.00
Medicare	65.00	65.25	(0.25)
Telephone	3,000.00	2,322.46	677.54
Tax Map Update	1,950.00	1,950.00	-
Reg. Of Deeds	750.00	374.79	375.21
Training	1,000.00	400.00	600.00
Service Contracts	1,800.00	1,270.14	529.86
Advertising & Public Notices	2,500.00	1,092.00	1,408.00
Office Supplies	3,000.00	1,847.70	1,152.30
Dues & Subscriptions	1,285.00	295.00	990.00
Postage	6,000.00	5,688.25	311.75
Rentals & Repairs	3,000.00	2,979.72	20.28
Books & Forms	1,000.00	1,101.49	(101.49)
Mileage/Travel/Misc.	1,000.00	1,336.80	(336.80)
Equipment	1,000.00	-	1,000.00
Selectmen's Office Salaries	33,529.00	34,340.41	(811.41)
Health Insurance	2,508.00	2,604.00	(96.00)
Life/Disability	400.00	396.48	3.52
SS/FICA	2,250.00	2,273.20	(23.20)
Medicare	530.00	531.75	(1.75)
Retirement	2,650.00	2,755.96	(105.96)
Town Meeting Moderator	200.00	-	200.00
Town Meeting Sound System Rental	300.00	300.00	0.00
Town Report Printing	3,500.00	3,555.19	(55.19)
<b>Subtotal Executive</b>	<b>\$ 77,997.00</b>	<b>\$ 72,259.59</b>	<b>\$ 5,737.41</b>
<b>ELECTIONS</b>			
Town Clerk's Office - Salaries	21,504.00	22,597.17	(1,093.17)
Health Insurance	6,350.00	6,347.63	2.37
Life/Disability	325.00	326.97	(1.97)
SS/FICA	1,450.00	1,245.21	204.79
Medicare	350.00	291.24	58.76
Retirement	1,750.00	2,190.41	(440.41)
Auditing Services	22,000.00	18,811.88	3,188.12
Ballot Clerks	350.00	183.75	166.25
Supervisor Salaries	500.00	420.00	80.00
Advertising & Public Notices	200.00	168.00	32.00
Printing & Supplies	200.00	28.67	171.33
Postage	200.00	-	200.00
Meals & Services	200.00	242.74	(42.74)
Dog Tags & Licenses	500.00	135.31	364.69
<b>Subtotal Elections</b>	<b>\$ 55,879.00</b>	<b>\$ 52,988.98</b>	<b>\$ 2,890.02</b>
<b>LEGAL EXPENSE</b>			
Town Attorney	22,000.00	16,380.41	5,619.59
Other Legal/Consult. Exp.	15,000.00	255.00	14,745.00
Consultant Forester	3,000.00	472.50	2,527.50
<b>Subtotal Legal Expenses</b>	<b>\$ 40,000.00</b>	<b>\$ 17,107.91</b>	<b>\$ 22,892.09</b>
<b>INSURANCE</b>			
Unemployment	1,500.00	498.81	1,001.19
Worker's Compensation	22,000.00	21,490.08	509.92
Property Liability	31,500.00	32,200.37	(700.37)
<b>Subtotal Insurance</b>	<b>\$ 55,000.00</b>	<b>\$ 54,189.26</b>	<b>\$ 810.74</b>

	<b>2007 Budgeted</b>	<b>2007 Expended</b>	<b>(Over)/Under Budget</b>
<b>PLANNING BOARD</b>			
Registry of Deeds	500.00	134.50	365.50
Clerical	750.00	645.00	105.00
SS/FICA	50.00	39.99	10.01
Retirement	52.00	-	52.00
Medicare	15.00	9.35	5.65
Advertising & Public Notices	1,250.00	1,500.00	(250.00)
Postage	500.00	1,223.35	(723.35)
Miscellaneous	3,000.00	255.00	2,745.00
<b>Subtotal Planning</b>	<b>\$ 6,117.00</b>	<b>\$ 3,807.19</b>	<b>\$ 2,309.81</b>
<b>FINANCIAL ADMINISTRATION</b>			
Assessing Services	29,000.00	31,897.45	(2,897.45)
Tax Collector - Salaries	21,530.00	20,402.48	1,127.52
Tax Bills	1,000.00	640.25	359.75
Treasurer-Salary	500.00	500.00	
SS-FICA	1,355.00	1,366.57	(11.57)
Medicare	335.00	319.48	15.52
Health Insurance	6,350.00	6,347.53	2.47
Life/Disability	325.00	326.99	(1.99)
Retirement	2,225.00	2,190.41	34.59
Software Support	5,560.00	5,560.32	(0.32)
<b>Subtotal Financial Administration</b>	<b>\$ 68,180.00</b>	<b>\$ 69,551.48</b>	<b>\$ (1,371.48)</b>
<b>Cemetery</b>			
Materials & Supplies	500.00	-	500.00
PSNH	500.00	112.98	387.02
Lawns R Us	22,000.00	16,000.26	5,999.74
<b>Subtotal Cemetery</b>	<b>\$ 23,000.00</b>	<b>\$ 16,113.24</b>	<b>\$ 6,886.76</b>
<b>GENERAL GOVERNMENT BUILDINGS</b>			
Town Hall Custodial Services	4,000.00	3,957.12	42.88
Town Hall Electricity	3,500.00	2,597.43	902.57
Town Hall Heating Oil	7,500.00	9,906.15	(2,406.15)
Water Town Buildings	1,400.00	806.90	593.10
Sewer Town Buildings	1,400.00	641.90	758.10
Town Hall Repairs & Maintenance	5,000.00	4,741.55	258.45
Town Hall Equipment & Supplies	5,000.00	3,929.29	1,070.71
Library Repairs & Maintenance	1,000.00	-	1,000.00
<b>Subtotal General Government Buildings</b>	<b>\$ 28,800.00</b>	<b>\$ 26,580.34</b>	<b>\$ 2,219.66</b>
<b>ADVERTISING &amp; REGIONAL ASSOCS.</b>			
NHMA Dues	1,400.00	1,313.27	86.73
North Country Council	2,083.00	2,082.34	0.66
Community Action Program	2,500.00	2,500.00	
Information Booth	3,500.00	3,696.90	(196.90)
<b>Subtotal Advertising &amp; Regional Assocs.</b>	<b>\$ 9,483.00</b>	<b>\$ 9,592.51</b>	<b>\$ (109.51)</b>
<b>SUBTOTAL GENERAL GOVERNMENT</b>	<b>\$ 364,456.00</b>	<b>\$ 322,190.50</b>	<b>\$ 42,265.50</b>

	<i>2007 Budgeted</i>	<i>2007 Expended</i>	<i>(Over)/Under Budget</i>
<b>PUBLIC SAFETY</b>			
<b>POLICE</b>			
Salaries	\$190,031.00	173,834.99	16,196.01
Overtime	7,000.00	7,095.45	(95.45)
Special Details	10,000.00	6,794.09	3,205.91
WMRHS School Resource Officer	0.00	15,454.85	(15,454.85)
Health Insurance	25,300.00	25,275.12	24.88
Life/Disability Insurance	1,859.00	1,792.78	66.22
SS/FICA	2,500.00	1,417.01	1,082.99
Medicare	3,025.00	2,874.46	150.54
Police Retirement	19,000.00	19,521.32	(521.32)
Telephone	7,800.00	7,442.18	357.82
Employee Physicals	100.00	-	100.00
Film & Developing	200.00	228.99	(28.99)
Training/Conventions/Seminars	1,000.00	604.36	395.64
Vehicle Maintenance & Repairs	3,500.00	5,230.72	(1,730.72)
Advertising & Public Notices	500.00	54.00	446.00
Dues & Subscriptions	300.00	240.00	60.00
Office Supplies	500.00	290.37	209.63
Computer Supplies	600.00	897.58	(297.58)
Computer Hardware	1,000.00	872.16	127.84
Postage	200.00	159.11	40.89
Gasoline	10,000.00	9,090.34	909.66
Books & Periodicals	300.00	199.85	100.15
Departmental Supplies	1,000.00	472.48	527.52
Mileage & Meals	1,000.00	70.00	930.00
Uniforms	2,000.00	413.72	1,586.28
Pedestrian Signs	500.00	333.00	167.00
Equipment	1,000.00	554.35	445.65
Firearms & Ammunition	1,500.00	1,037.75	462.25
<b>Subtotal Police</b>	<b>\$ 291,715.00</b>	<b>\$ 282,251.03</b>	<b>\$ 9,463.97</b>
<b>FIRE-RESCUE</b>			
Fire Department Salaries	25,000.00	19,225.68	5,774.32
Chief/Asst. Chief Salaries	6,500.00	6,500.00	0.00
Captian/Lieutenant Salary	2,200.00	1,997.91	202.09
SS/FICA	2,100.00	1,718.90	381.10
Medicare	500.00	401.98	98.02
Telephone	4,000.00	4,181.72	(181.72)
Employee Physicals	500.00	0.00	500.00
Training	3,000.00	1,035.00	1,965.00
Fire Station Electricity	3,000.00	3,838.79	(838.79)
Fire Station Heating Oil	6,000.00	2,714.91	3,285.09
Fire Station Repairs & Maintenance	3,000.00	533.27	2,466.73
Equipment Maintenance	6,000.00	7,688.26	(1,688.26)
Dues & Subscriptions	1,000.00	976.00	24.00
Vehicle Fuel	1,200.00	1,960.68	(760.68)
Departmental Supplies	6,000.00	2,181.19	3,818.81
Fire Department Equipment	18,000.00	15,027.61	2,972.39
Fire Prevention	2,000.00	926.42	1,073.58
Ambulance Salaries	49,900.00	29,425.00	20,475.00
Ambulance EMT/Admin. Asst.	25,878.00	26,829.65	(951.65)
Ambulance Medicare	1,100.00	803.29	296.71
Ambulance NH Retirement	2,350.00	2,096.96	253.04
Ambulance Health Insurance	4,500.00	4,455.36	44.64
Ambulance Life/Disability	375.00	326.52	48.48
Ambulance SS/FICA	4,700.00	3,433.54	1,266.46

	<b>2007</b> <b>Budgeted</b>	<b>2007</b> <b>Expended</b>	<b>(Over)/Under</b> <b>Budget</b>
Ambulance Departmental Supplies	7,000.00	6,256.32	743.68
Ambulance Training	3,000.00	875.00	2,125.00
Ambulance Gasoline	2,500.00	2,789.26	(289.26)
Ambulance Equipment	5,000.00	2,576.16	2,423.84
Ambulance Uniforms	2,000.00	652.95	1,347.05
Ambulance Maintenance	5,000.00	4,745.45	254.55
Vaccines/Testing	3,000.00	263.50	2,736.50
<b>Subtotal Fire-Rescue</b>	<b>\$ 206,303.00</b>	<b>\$ 156,437.28</b>	<b>\$ 49,865.72</b>
<b>OTHER SAFETY</b>			
Hepatitis B Vaccine	500.00	84.00	416.00
<b>SUBTOTAL PUBLIC SAFETY</b>	<b>\$ 498,518.00</b>	<b>\$ 438,772.25</b>	<b>\$ 59,745.75</b>
<b>HIGHWAYS &amp; STREETS</b>			
Salaries	89,870.00	91,159.69	(1,289.69)
Road Agent Salary	43,775.00	44,608.73	(833.73)
Overtime	17,500.00	21,551.59	(4,051.59)
Health Insurance	35,700.00	35,372.63	327.37
Life/Disability	1,500.00	1,601.31	(101.31)
SS/FICA	9,500.00	9,789.64	(289.64)
Medicare	2,500.00	2,289.66	210.34
Retirement	12,000.00	13,250.51	(1,250.51)
Bridge Inspections	500.00	-	500.00
Telephone/Cells/Pagers	1,000.00	1,721.69	(721.69)
Physicals & Drug Testing	500.00	960.75	(460.75)
Contract Services	7,000.00	4,909.09	2,090.91
Training/Conventions/Seminars	-	1,080.00	(1,080.00)
Highway Garage Electricity	4,000.00	2,874.50	1,125.50
Highway Garage Heating Oil	2,000.00	-	2,000.00
Highway Garage Repairs & Mnt.	10,000.00	16,443.57	(6,443.57)
Vehicle Maintenance & Repairs	20,000.00	32,803.09	(12,803.09)
Sidewalk Maintenance & Repair	12,500.00	10,000.00	2,500.00
Vehicle Fuel	16,000.00	32,534.68	(16,534.68)
Lubricants & Motor Oil	2,000.00	1,555.99	444.01
Departmental Supplies	5,000.00	7,511.82	(2,511.82)
Chloride	3,500.00	-	3,500.00
Salt	35,000.00	37,551.62	(2,551.62)
Sand & Gravel/Road Cons. Mnt.	36,000.00	43,158.83	(7,158.83)
Street Signs/Traffic Control	1,000.00	251.54	748.46
Oxygen/Acetylene	750.00	371.30	378.70
Asphalt/Hot Mix/Cold Patch	33,500.00	30,105.30	3,394.70
Mileage/Travel/Misc.	500.00	252.59	247.41
Uniforms	2,000.00	1,964.07	35.93
Roadside Mowing	4,500.00	4,530.00	(30.00)
Capital Equipment	6,000.00	6,460.74	(460.74)
Street Sweeping	5,400.00	5,400.00	-
Equipment Rental	4,000.00	-	4,000.00
Hazard Tree Removal	1,500.00	0.00	1,500.00
<b>Subtotal Public Works</b>	<b>\$ 426,495.00</b>	<b>\$ 462,064.93</b>	<b>\$ (35,569.93)</b>
<b>STREET LIGHTING</b>			
Street Lighting	15,000.00	18,167.48	(3,167.48)
Light Replacement	1,000.00	473.89	526.11
<b>Subtotal Street Lights</b>	<b>\$ 16,000.00</b>	<b>\$ 18,641.37</b>	<b>\$ (2,641.37)</b>
<b>SUBTOTAL HIGHWAYS &amp; STREETS</b>	<b>\$ 442,495.00</b>	<b>\$ 480,706.30</b>	<b>\$ (38,211.30)</b>

	<b>2007 Budgeted</b>	<b>2007 Expended</b>	<b>(Over)/Under Budget</b>
<b>TRANSFER STATION</b>			
Salaries	43,360.00	52,829.35	(9,469.35)
Health Insurance	680.00	1,827.36	(1,147.36)
Life/Disability	325.00	266.22	58.78
SS/FICA	2,700.00	3,337.58	(637.58)
Medicare	650.00	780.60	(130.60)
Retirement	3,400.00	2,200.57	1,199.43
Transportation	12,000.00	15,146.49	(3,146.49)
Telephone	500.00	454.84	45.16
Hazardous Waste Collection	2,000.00	224.52	1,775.48
Electricity	1,700.00	1,580.44	119.56
Propane	250.00	172.28	77.72
Maintenance & Repairs	2,500.00	5,747.15	(3,247.15)
Tipping Fees	33,000.00	35,055.38	(2,055.38)
Permits, Testing & Engineering	5,000.00	3,275.86	1,724.14
Supplies	2,000.00	735.16	1,264.84
Mileage, Travel, Training, Meals	750.00	709.63	40.37
Uniforms	500.00	597.20	(97.20)
Pay-Per-Bag Purchases	5,500.00	5,505.34	(5.34)
Fuel & Oil	800.00	826.71	(26.71)
<b>Subtotal Solid Waste</b>	<b>\$ 117,615.00</b>	<b>\$ 131,272.68</b>	<b>\$ (13,657.68)</b>
<b>Street Sewer</b>			
Maintenance & Repairs	10,000.00	11,073.55	(1,073.55)
<b>Subtotal Street Sewer</b>	<b>\$ 10,000.00</b>	<b>\$ 11,073.55</b>	<b>\$ (1,073.55)</b>
<b>SUBTOTAL SANITATION</b>	<b>\$ 127,615.00</b>	<b>\$ 142,346.23</b>	<b>\$ (14,731.23)</b>
<b>HEALTH &amp; WELFARE</b>			
<b>HEALTH</b>			
Health Officer	1,000.00	1,000.00	-
SS/FICA	62.00	62.00	-
Medicare	15.00	14.50	0.50
Vet. Services	500.00	164.00	336.00
<b>Subtotal Health</b>	<b>\$ 1,577.00</b>	<b>\$ 1,240.50</b>	<b>\$ 336.50</b>
<b>WELFARE/PUBLIC ASSISTANCE</b>			
Electricity	6,000.00	3,400.30	2,599.70
Heat & Oil	8,000.00	4,925.48	3,074.52
Rentals	13,000.00	16,253.00	(3,253.00)
Food & Other	5,000.00	569.13	4,430.87
Mortgage Payments	3,000.00	479.00	2,521.00
<b>Subtotal Welfare</b>	<b>\$ 35,000.00</b>	<b>\$ 25,626.91</b>	<b>\$ 9,373.09</b>
<b>SUBTOTAL HEALTH &amp; WELFARE</b>	<b>\$ 36,577.00</b>	<b>\$ 26,867.41</b>	<b>\$ 9,709.59</b>
<b>CULTURE &amp; RECREATION</b>			
<b>RECREATION</b>			
Payroll	27,757.00	18,634.70	9,122.30
Community Day	2,000.00	1,357.96	642.04
SS/FICA	1,725.00	1,155.41	569.59
Medicare	405.00	270.23	134.77
Advertising	400.00	168.00	232.00
Bus/Mileage Expenses	8,000.00	4,151.00	3,849.00
Swimming Lesson Program	1,200.00	1,200.00	-
Program Supplies	4,450.00	3,851.22	598.78
Supplies/Maintenance	2,000.00	563.27	1,436.73
<b>Subtotal Recreation</b>	<b>\$ 47,937.00</b>	<b>\$ 31,351.79</b>	<b>\$ 16,585.21</b>

	<u>2007 Budgeted</u>	<u>2007 Expended</u>	<u>(Over)/Under Budget</u>
<b>PARKS &amp; PLAYGROUNDS</b>			
Electricity	2,500.00	1,855.90	644.10
Repairs/Maintenance/Supplies/Mowing	20,000.00	5,866.26	14,133.74
<b>Subtotal Parks &amp; Playgrounds</b>	<b>\$ 22,500.00</b>	<b>\$ 7,722.16</b>	<b>\$ 14,777.84</b>
<b>PATRIOTIC PURPOSES/MEMORIAL DAY</b>			
	500.00	585.60	(85.60)
<b>Subtotal Patriotic Purposes</b>	<b>\$ 500.00</b>	<b>\$ 585.60</b>	<b>\$ (85.60)</b>
<b>SUBTOTAL CULTURE &amp; RECREATION</b>	<b>\$ 70,937.00</b>	<b>\$ 39,659.55</b>	<b>\$ 31,277.45</b>
<b>CONSERVATION COMMISSION</b>			
	3,400.00	255.00	3,145.00
<b>SUBTOTAL CONSERVATION COMM.</b>	<b>\$ 3,400.00</b>	<b>\$ 255.00</b>	<b>\$ 3,145.00</b>
<b>ECONOMIC DEVELOPMENT CORP.</b>			
	5,000.00	4,154.24	845.75
<b>SUBTOTAL ECON. DEV. CORP.</b>	<b>\$ 5,000.00</b>	<b>\$ 4,154.24</b>	<b>\$ 845.75</b>
<b>DEBT SERVICE</b>			
Principal Bonds & Notes	82,427.00	82,375.84	51.16
Interest Bonds & Notes	53,982.00	53,984.72	(2.72)
Interest Tax Anticipation Notes	7,500.00	0.00	7,500.00
<b>SUBTOTAL DEBT SERVICE</b>	<b>\$ 143,909.00</b>	<b>\$ 136,360.56</b>	<b>\$ 7,548.44</b>
<b>WARRANT ARTICLES</b>			
Zoll Defibrillators	39,400.00	37,614.06	1,785.94
Water Department Hydraulic Model	6,750.00	5,700.00	1,050.00
Spring Street Rehab. & Repairs	61,000.00	61,000.00	-
Master Plan Update	16,000.00	-	16,000.00
Landfill Closure	70,000.00	69,825.00	175.00
<b>Subtotal Warrant Articles</b>	<b>\$ 193,150.00</b>	<b>\$ 174,139.06</b>	<b>\$ 19,010.94</b>
<b>CAPITAL RESERVES</b>			
Ambulance	15,000.00	15,000.00	
Emergency Services Building	15,000.00	15,000.00	
Fire Dept. Eqpt. Replacement	15,000.00	15,000.00	
Police Cruiser	10,000.00	10,000.00	
Highway Equipment Replacement	15,000.00	15,000.00	
<b>Subtotal Capital Reserves</b>	<b>\$ 70,000.00</b>	<b>\$ 70,000.00</b>	
<b>PETITION WARRANT ARTICLES</b>			
Weeks Home Health	10,536.00	10,536.00	
Ammonoosuc Com. Health Services	2,500.00	2,500.00	
White Mountain Mental Health	2,862.00	2,862.00	
Caleb Group	3,300.00	3,300.00	
North Country Home Health Agency	3,064.00	3,064.00	
North Country Transportation/Sr. Wheels	3,100.00	3,100.00	
Meals-on-Wheels	2,800.00	2,800.00	
<b>Subtotal Petition Warrant Articles</b>	<b>\$ 28,162.00</b>	<b>\$ 28,162.00</b>	
<b>SPECIAL REVENUE FUNDS</b>			
Library	33,500.00	33,500.00	
Airport	9,000.00	9,000.00	
Band Concerts	3,500.00	3,500.00	
<b>Subtotal Special Revenue Funds</b>	<b>\$ 46,000.00</b>	<b>\$ 46,000.00</b>	
<b>TOTAL BUDGET</b>	<b>\$ 2,030,219.00</b>	<b>\$ 1,909,613.10</b>	<b>\$ 120,605.90</b>



# 2007 PAYROLL BY DEPARTMENT

Employee's Name	Regular Wages	Overtime Wages	Gross Wages
<b>EXECUTIVE &amp; OFFICIALS</b>			
Stephanie Glidden*	\$ 25,118.42		\$ 25,118.42
Jay Hartnett	\$ 1,500.00		\$ 1,500.00
Amy Hatfield	\$ 500.00		\$ 500.00
Wendy Hersom	\$ 1,500.00		\$ 1,500.00
Duane Hall	\$ 1,500.00		\$ 1,500.00
Joyce McGee	\$ 28,605.98		\$ 28,605.98
Judy Ramsdell	\$ 32,644.16		\$ 32,644.16

\*Includes Planning Bd. Sec.

Employee's Name	Regular Wages	Overtime Wages	Spec. Det./On-Call	Gross Wages
<b>POLICE DEPARTMENT</b>				
Blaine Hall	\$ 540.00		\$ 100.00	\$ 640.00
Michael Bouton	\$ 33,353.92	\$ 2,521.04	\$ 4,120.00	\$ 39,994.96
Patti Rexford	\$ 3,569.00			\$ 3,569.00
Sandra Gordon	\$ 9,871.07			\$ 9,871.07
Eric Perry	\$ 672.00			\$ 672.00
William Colborn	\$ 54,219.21		\$ 100.00	\$ 54,319.21
Shawn White	\$ 40,616.00	\$ 3,135.99	\$ 3,599.00	\$ 47,350.99
Richard Brown	\$ 2,334.00		\$ 100.00	\$ 2,434.00
Edward Dorr	\$ 3,630.00	\$ 144.00	\$ 200.00	\$ 3,974.00
Ryan Kennett	\$ 34,413.50	\$ 2,374.51	\$ 2,575.00	\$ 39,363.01
William Thompson	\$ 1,595.50			\$ 1,595.50

**PUBLIC WORKS DEPT.**

James Gooden	\$ 26,190.72	\$ 54.00		\$ 26,244.72
Frederick Ingerson, II	\$ 29,686.31	\$ 7,797.40	\$ 2,200.00	\$ 39,683.71
Nathan St. Cyr	\$ 10,640.00	\$ 2,025.02	\$ 800.00	\$ 13,465.02
Steve Kenison	\$ 44,608.73			\$ 44,608.73
David Glidden	\$ 23,515.50	\$ 3,782.62	\$ 2,100.00	\$ 29,398.13
Jay Watkins	\$ 13,388.00	\$ 2,188.88	\$ 800.00	\$ 16,376.88
Rebecca Pederson	\$ 2,004.66			\$ 2,004.66
William Robinson	\$ 35,578.50			\$ 35,578.50
William Thompson	\$ 39,423.00			\$ 39,423.00
Wyatt Thompson	\$ 16,236.05	\$ 675.01	\$ 1,400.00	\$ 18,311.06
David Libby	\$ 22,233.51	\$ 5,024.46	\$ 2,200.00	\$ 29,457.97

**INSURANCE BUY-OUT**

James Gooden	\$ 1,827.36
Joyce McGee	\$ 2,285.28
Judy Ramsdell	\$ 2,604.00
Jay Watkins	\$ 918.48

# 2007 PAYROLL BY DEPARTMENT

Employee's Name	Regular Wages	Overtime Wages	Gross Wages
<b>WHITEFIELD FIRE-RESCUE</b>			
Douglas Allen	\$ 710.00		\$ 710.00
Michael Authier	\$ 20.00		\$ 20.00
Matthew Berg	\$ 69.00		\$ 69.00
Joanna Enman	\$ 290.00		\$ 290.00
Robert Blanchette	\$ 1,503.00		\$ 1,503.00
Lori Comeau	\$ 3,619.00		\$ 3,493.00
Domenico D'arcangelo	\$ 30.00		\$ 112.00
Stephanie Cormier	\$ 48.00		\$ 48.00
Joshua Couturier	\$ 421.00		\$ 421.00
Lorna Greer	\$ 1,236.02		\$ 1,236.02
Arthur Duguay	\$ 431.22		\$ 431.22
Elwin Greer	\$ 1,208.02		\$ 1,208.02
David Laflamme	\$ 409.00		\$ 409.00
Richard Grima, Sr.	\$ 3,188.48		\$ 3,188.48
Keri Mellett	\$ 2,246.00		\$ 2,246.00
Shawn Grover	\$ 1,285.62		\$ 1,285.62
Thomas Ladd	\$ 1,729.00		\$ 1,729.00
Brian Lennox	\$ 726.60		\$ 726.60
Richard Grima, Jr.	\$ 383.00		\$ 383.00
Sean McAlister	\$ 26,236.40	\$ 593.25	\$ 26,829.65
Ann Miller*	\$ 4,672.00		\$ 4,672.00
Barry Page	\$ 432.91		\$ 432.91
Donna Page	\$ 80.00		\$ 80.00
Terry Schmidt	\$ 3,702.84		\$ 3,702.84
Zina Schmidt	\$ 5,004.02		\$ 5,004.02
Mark Sodergren	\$ 928.00		\$ 928.00
John St. Martin	\$ 1,212.00		\$ 1,212.00
Anthony Stiles	\$ 7,455.24		\$ 7,455.24
Kelly Sweeney	\$ 480.00		\$ 480.00
James Watkins	\$ 6,181.20		\$ 6,181.20
John Wilkinson	\$ 4,249.00		\$ 4,249.00
Clifford Vendt	\$ 378.40		\$ 378.40
Steven Jones	\$ 310.00		\$ 310.00
Jason Marro	\$ 998.02		\$ 998.02
Samantha Page	\$ 83.00		\$ 83.00
Amanda St. Martin	\$ 1,227.00		\$ 1,227.00
Michael McCarthy	\$ 940.00		\$ 940.00
William Jones	\$ 340.00		\$ 340.00
*Includes Health Officer Salary			
<b>INFORMATION BOOTH</b>			
Janice Ruth	\$ 3,541.51	\$ 11.44	\$ 3,552.95
<b>RECREATION DEPARTMENT</b>			
Jessica Laplante	\$ 1,490.00		\$1,490.00
Katherine Burt	\$ 1,768.00	\$ 42.00	\$ 1,810.00
Michael Burt	\$ 1,361.20		\$ 1,361.20
Jennie Anderson	\$ 891.00		\$ 891.00
Amelia Copson	\$ 829.50		\$ 829.50
Kerstin Corey	\$ 1,022.00		\$ 1,022.00
Kelly Smith	\$ 4,515.50	\$ 342.00	\$ 4,857.50
Erin Kelly	\$ 1,026.00		\$ 1,026.00
Matthew Riley	\$ 986.00		\$ 986.00
Jaimie-Lynn Foley	\$ 891.00		\$ 891.00
Zebediah Galipeau	\$ 850.50		\$ 850.50
Kristi Macleod	\$ 2,387.50	\$ 52.50	\$ 2,440.00

**TOWN OF WHITEFIELD, NEW HAMPSHIRE**

**ANNUAL MEETING WARRANT - MARCH 11, 2008**

**THE POLLS WILL BE OPEN FROM 8:00 AM TO 6:00 PM**

**TOWN MEETING WILL BEGIN AT 7:30 PM**

To the inhabitants of the Town of Whitefield, in the County of Coos, and State of New Hampshire, qualified to vote in town affairs:

You are hereby notified to meet in the auditorium of the C.D. McIntyre Building on Highland Street in said Whitefield on Tuesday, the eleventh day of March, next at 8:00 of the clock in the forenoon until 6:00 p.m. for the casting of ballots, and at 7:30 in the same day to act upon the following subjects:

**ARTICLE ONE WILL APPEAR ON THE OFFICIAL BALLOT AND WILL BE VOTED ON FROM 8:00 AM TO 6:00 PM.**

**Article 1.** To choose one selectperson for a three year term, one treasurer for a one year term, one trustee of trust funds for a three year term, two library trustees for three year terms, one cemetery trustee for a three year term, and one supervisor of the checklist for a three year term, and one moderator for a two year term.

**THE FOLLOWING ARTICLES WILL BE TAKEN UP DURING THE BUSINESS MEETING BEGINNING AT 7:30 P.M.**

**Article 2.** To raise and appropriate such sums of money as may be necessary for:

General Government:

Executive - \$81,975

Election, Registration & Vital Statistics - \$68,760

Financial Administration - \$69,366

Legal Expense - \$40,000

Planning & Zoning - \$6,117

General Government Buildings - \$30,800

Cemeteries - \$5,000

Insurance - \$56,000

Public Safety

Police Department - \$349,450

Ambulance - \$0

Fire-Rescue - \$210,329

Emergency Management - \$1,560

Other Public Safety/Safety/Hepatitis B Vaccine - \$2,500

Airport Operations - \$12,000

Highways/Streets & Bridges

Highways & Streets - \$509,180

Bridges - \$14,400

Street Lighting - \$19,000

Sanitation

Transfer Station/Solid Waste Disposal - \$139,893

Sewage Collection/Disposal & Other - \$12,000

Health

Health Officer - \$1,077

Vet Service - \$500

Welfare

Welfare/Direct Assistance - \$37,000

Culture & Recreation

Parks & Recreation /Common - \$70,437

Library - \$34,750

Memorial Day - \$600

Band Concerts - \$3,500

Conservation Commission - \$3,400

Economic Development - \$5,000

Debt Service

Principal - Long Term Bonds & Notes - \$83,890

Interest - Long Term Bonds & Notes - \$50,335

Interest on Tax Anticipation Notes - \$7,500

Municipal Sewer Department

Operation & Maintenance Expenses - \$126,935

Municipal Water Department

Operation & Maintenance Expenses - \$146,800

**Article 3.** To see if the Town will vote to change the Optional Military Veteran's Tax Credit from \$300.00 to \$500.00. (By Petition) The Board of Selectmen recommend this article.

**Article 4.** To see if the Town will vote to authorize the Board of Selectmen to sell certain town-owned property shown on Tax Map 102, Lot 036, approximately 0.20 acres, located at 42 Brown Street. Said property will be sold by the Town upon such reasonable terms and conditions as may be negotiated and agreed by the Selectmen and to authorize the Selectmen to execute all documents and take all other actions reasonable and necessary to carry out the purpose of this vote. The Board of Selectmen recommend this article.

**Article 5.** To see if the Town will vote to authorize the appointment rather than the election of a town treasurer pursuant to RSA 41:26-e. Such appointment shall be made in accordance with RSA 669:17-d by the Board of Selectmen. The Board of Selectmen recommend this article.

**Article 6.** To see if the Town will vote to discontinue the following Capital Reserve Funds which currently have no balance: The Board of selectmen recommend his article.

- Cruiser Capital Reserve Fund - Created in 1993, Funds spent in 1995
- Landfill Closure Capital Reserve Fund - Created in 1994, Funds returned to general fund in 1998
- Fire Truck Capital Reserve Fund - Created in year unknown, Funds spent in 1994
- Highway Grader Capital Reserve Fund - Created in 1995, Funds returned to general fund in 1998
- Fire Truck Capital Reserve Fund - Created in 1995, Funds spent in 1997
- Cruiser Capital Reserve Fund - Created in 1996, Funds spent in 1998
- Highway Equipment Capital Reserve Fund - Created in 1996, Funds spent in 1998
- G.I.S. Capital Reserve Fund - Created in 1996, Funds spent in 1998
- Salt Shed Capital Reserve Fund - Created in 1999, Funds spent in 2001
- Police Cruiser Capital Reserve Fund - Created in 2004, Funds spent in 2006

**Article 7.** Shall we delegate the duties and responsibilities of the cemetery trustees to the Board of Selectmen pursuant to RSA 289:6? The Board of Selectmen recommend this article.

**Article 8.** To see if the Town will vote to establish a Capital Reserve Fund under the provisions of RSA 35:1 for the purpose of Road Repairs and Rehabilitation and to raise and appropriate the sum of Twenty-Five Thousand Dollars (\$25,000) to be placed in this fund. The Board of Selectmen recommend this appropriation.

**Article 9.** To see if the Town will vote to raise and appropriate the sum of Fifteen Thousand Dollars (\$15,000) to be added to the Ambulance Capital Reserve Fund created in 2004. The Board of Selectmen recommend this appropriation.

**Article 10.** To see if the Town will vote to raise and appropriate the sum of Fifteen Thousand Dollars (\$15,000) to be added to the Fire Department Equipment Replacement Fund created in 2007. The Board of Selectmen recommend this appropriation.

**Article 11.** To see if the Town will vote to raise and appropriate the sum of Ten Thousand Dollars (\$10,000) to be added to the Police Cruiser Capital Reserve Fund created in 2007. The Board of Selectmen recommend this appropriation.

**Article 12.** To see if the Town will vote to raise and appropriate the sum of Seventy-Five Thousand Dollars (\$75,000) to be added to the Highway Equipment Replacement Fund created in 2001. The Board of Selectmen recommend this appropriation.

**Article 13.** To see if the Town will vote to raise and appropriate the sum of Twenty-Five Thousand Dollars (\$25,000) to be added to the Revaluation Capital Reserve Fund. The Board of Selectmen recommend this appropriation.

**Article 14.** To see if the Town will vote to raise and appropriate the sum of Five Hundred Thousand Dollars (\$500,000) for the purpose of replacing the bridge on Airport road over the Airport Marsh (Bridge#166/096). Out of this amount, \$400,000 is to come from the State Bridge Aid Construction Program with the remaining \$100,000 to come from taxation. This appropriation will be non-lapsing and will not lapse until December 31, 2009. The Board of Selectmen recommend this appropriation.

**Article 15.** To see if the Town will vote to raise and appropriate the sum of Six Thousand Dollars (\$6,000) for a Capital Improvements Program. The Board of Selectmen recommend this appropriation.

**Article 16.** To see if the Town will vote to raise and appropriate the sum of Fifteen Thousand Dollars (\$15,000) to be added to the Water Department Repair and Replacement Expendable General Trust Fund established in 1990. The Board of Selectmen recommend this appropriation.

**Article 17.** To see if the Town will vote to raise and appropriate the sum of Thirteen Thousand Dollars (\$13,000) for a Water Department Phone Line Upgrade and authorize the withdrawal of said sum from the Water Department Repair and Replacement Expendable General Trust Fund established in 1990 with no amount to be raised by taxation. The Board of Selectmen recommend this appropriation.

**Article 18.** To see if the Town will vote to raise and appropriate the amount of One Hundred Thousand Dollars (\$100,000) to be administered by an agent of the Whitefield Economic Development Corporation for the purpose of beginning rehabilitation of the downtown area surrounding the Whitefield Common. (By Petition) The Board of Selectmen do not recommend this appropriation.

**Article 19.** To see if the Town will vote to raise and appropriate the sum of Ten Thousand Eight Hundred and Fifty-Two Five Dollars (\$10,852) for the Weeks Medical Center - Home Health & Hospice Services to be used to assist in the delivery of home health and hospice services to the residents of the Town of Whitefield (By Petition) The Board of Selectmen recommend this appropriation.

**Article 20.** To see if the Town will vote to raise and appropriate the sum of Two Thousand Eight Hundred and Sixty-Two Dollars (\$2,862) as the Town of Whitefield's contribution to the White Mountain Mental Health and Common Ground programs of Northern Human Services, serving the mental health and developmental service needs of Whitefield residents. (By Petition) The Board of Selectmen recommend this appropriation.

**Article 21.** To see if the Town will vote to raise and appropriate the sum of Three Thousand Three Hundred Dollars (\$3,300) to help support The Caleb Interfaith Volunteer Caregivers, that serves the needs of elderly and disabled people in the community. (By Petition) The Board of Selectmen recommend this appropriation.

**Article 22.** To see if the Town will vote to raise and appropriate the sum of Two Thousand Eight Hundred Dollars (\$2,800) in support of the Tri-County CAP, Inc.--North Country Elder Programs Senior Meals Program. (By Petition) The Board of Selectmen recommend this appropriation.

**Article 23.** To see if the Town will vote to raise and appropriate the sum of Three Thousand Five Hundred Dollars (\$3,500). Of that amount, the sum of One Thousand Eight Hundred Dollars (\$1,800) to support the Senior Wheels Demand Response Program and the sum of One Thousand Seven Hundred Dollars (\$1,700) to support the Lancaster-Whitefield-Littleton Tri-Town Public Transit Route. (By Petition) The Board of Selectmen recommend this appropriation.

**Article 24.** To see if the Town will vote to raise and appropriate the sum of Three Thousand Sixty-Four Dollar (\$3,064) for the support of the home health care, supportive care, medical hospice and community health programs and services of North Country Home Health & Hospice Agency, Inc. in the fiscal year 2008 for the residents of Whitefield, N.H. (By Petition) The Board of Selectmen recommend this appropriation.

**Article 25.** To see if the Town will vote to raise and appropriate the sum of Twenty-Five Hundred Dollars (\$2,500) for Ammonoosuc Community Health Services, Inc. (ACHS), a non-profit community health center offering a network of affordable primary health services. As a Federally Qualified Health Center, ACHS receives federal funding to provide comprehensive preventive and primary health care to anyone, regardless of their insurance status or ability to pay. This will help ACHS continue to provide high quality care to our current 955 current Whitefield patients, as well as reach more of those in need. (By Petition) The Board of Selectmen recommend this appropriation.

**Article 26.** To see if the Town will vote to raise and appropriate the sum of Two Thousand Dollars (\$2,000) and to turn such monies to the Littleton Regional Hospital in recognition of the Paramedic Intercept program assistance provided by the hospital to the Town's Emergency Medical Services (E.M.S.) and for community benefits provided by the hospital in support of the residents of Whitefield. (By Petition) The Board of Selectmen recommend this appropriation.

**Article 27.** To transact any other business that may lawfully come before said meeting.

Given under our hands and seal of the Town this eleventh day of February, 2008.

A TRUE COPY  
ATTEST

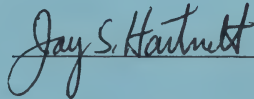





Jay Hartnett  
Wendy Hersom  
Duane Hall  
Board of Selectmen  
Town of Whitefield



# BUDGET OF THE TOWN

OF: Whitefield

Appropriations and Estimates of Revenue for the Ensuing Year January 1, 2008 to December 31, 2008

or Fiscal Year From \_\_\_\_\_ to \_\_\_\_\_

## IMPORTANT:

Please read RSA 32:5 applicable to all municipalities.

1. Use this form to list the operating budget and all special and individual warrant articles in the appropriate recommended and not recommended area. All proposed appropriations must be on this form.
2. Hold at least one public hearing on this budget.
3. When completed, a copy of the budget must be posted with the warrant. Another copy must be placed on file with the town clerk, and a copy sent to the Department of Revenue Administration at the address below within 20 days after the meeting.

This form was posted with the warrant on (Date): February 18, 2008

### GOVERNING BODY (SELECTMEN)

*Please sign in ink.*

Jay S. Hartnett  
Wendy Hanson  
D.H. Hill

\_\_\_\_\_  
 \_\_\_\_\_  
 \_\_\_\_\_

## THIS BUDGET SHALL BE POSTED WITH THE TOWN WARRANT

FOR DRA USE ONLY

NH DEPARTMENT OF REVENUE ADMINISTRATION  
 MUNICIPAL SERVICES DIVISION  
 P.O. BOX 487, CONCORD, NH 03302-0487  
 (603)271-3397

2

3

4

5

6

7

Purpose of Appropriations (RSA 32:3,V)	Warrant Article #	Appropriations Prior Year As Approved by DRA	Actual Expenditures Prior Year	Appropriations Ensuing FY (RECOMMENDED)	Appropriations Ensuing FY (NOT RECOM.)
<b>GENERAL GOVERNMENT</b>					
Executive	2	\$77,997.00	\$72,260.00	\$81,975.00	
Election, Regular and Vital Statistics	2	\$55,879.00	\$52,989.00	\$68,760.00	
Financial Administration	2	\$68,180.00	\$69,551.00	\$69,366.00	
Revaluation of Property					
Legal Expense	2	\$40,000.00	\$17,108.00	\$40,000.00	
Personnel Administration					
Planning and Zoning	2	\$6,117.00	\$3,807.00	\$6,117.00	
General Government Buildings	2	\$28,800.00	\$26,580.00	\$30,800.00	
Cemeteries	2	\$23,000.00	\$16,113.00	\$5,000.00	
Insurance	2	\$55,000.00	\$54,189.00	\$56,000.00	
Ads and Regional Assoc. NHMA dues	2	\$1,400.00	\$1,313.00	\$1,413.00	
Other General Government	2	\$8,083.00	\$8,280.00	\$8,923.00	
<b>PUBLIC SAFETY</b>					
Police	2	\$291,715.00	\$282,251.00	\$349,450.00	
Ambulance	2	\$116,303.00	\$85,529.00	\$0.00	
Fire-Rescue	2	\$90,000.00	\$70,908.00	\$210,329.00	
Building Inspection					
Emergency Management	2	\$0.00	\$0.00	\$1,560.00	
Other - Safety/Hepatitis B Vaccine	2	\$500.00	\$84.00	\$2,500.00	
<b>AIRPORT/AVIATION CENTER</b>					
Airport Operations	2	\$9,000.00	\$9,000.00	\$12,000.00	
<b>HIGHWAYS AND STREETS</b>					
Administration					
Highways and Streets	2	\$425,995.00	\$462,065.00	\$509,180.00	
Bridges	2	\$500.00	\$0.00	\$14,400.00	
Street Lighting	2	\$16,000.00	\$18,641.00	\$19,000.00	
Other					
<b>SANITATION</b>					
Administration					
Solid Waste Collection					
Solid Waste Disposal-Transfer Sta.	2	\$117,615.00	\$131,273.00	\$139,893.00	
Solid Waste Clean-up					
Sewage Coll. & Disposal & Other	2	\$10,000.00	\$11,074.00	\$12,000.00	
<b>WATER DISTRIBUTION &amp; TREATMENT</b>					
Administration					
Water Services					
Water Treatment, Conserv. & Other					
<b>ELECTRIC</b>					
Admin. & Generation					
Purchase Costs					
Electric Equipment Maintenance					
Other Electric Costs					
<b>HEALTH</b>					
Administration	2	\$1,577.00	\$1,241.00	\$1,577.00	
Pest Control - Vet Service					
Health Agency & Hosp. & Other					
<b>WELFARE</b>					
Administration & Direct Assist.	2	\$35,000.00	\$25,627.00	\$37,000.00	
Intergovernmental Welfare Payments					
Vendor Payments & Other					

2

3

4

5

6

7

Purpose of Appropriations (RSA 32:3,V)	Warrant Article #	Appropriations Prior Year As Approved by DRA	Actual Expenditures Prior Year	Appropriations Ensuing FY (RECOMMENDED)	Appropriations Ensuing FY (NOT RECOM.)
---	----------------------	--	--------------------------------------	---	--

**CULTURE AND RECREATION**

Parks and Recreation	2	\$70,437.00	\$39,074.00	\$70,437.00	
Library	2	\$33,500.00	\$33,500.00	\$34,750.00	
Patriotic Purposes - Memorial Day	2	\$500.00	\$586.00	\$600.00	
Other Culture & Rec. - Band Concerts	2	\$3,500.00	\$3,500.00	\$3,500.00	

**CONSERVATION**

Conservation Commission	2	\$3,400.00	\$255.00	\$3,400.00	
Other Conservation					
Redevelopment & Housing					
Economic Development	2	\$5,000.00	\$4,154.00	\$5,000.00	

**DEBT SERVICE**

Princ.-Long Term Bonds & Notes	2	\$82,427.00	\$82,376.00	\$83,890.00	
Interest-Long Term Bonds & Notes	2	\$53,982.00	\$53,985.00	\$50,335.00	
Int. on Tax Anticipation Notes	2	\$7,500.00	\$0.00	\$7,500.00	
Other Debt Service					

**CAPITAL OUTLAY**

Land					
Machinery, Vehicles & Equipment					
Buildings					
Improvements Other than Buildings					

**OPERATING TRANSFERS OUT**

To Special Revenue Fund					
To Capital Projects Fund					
To Enterprise Fund					
SEWER-	2	\$106,935.00	\$117,002.00	\$126,935.00	
WATER-	2	\$146,800.00	\$150,269.00	\$146,800.00	
ELECTRIC-					
AIRPORT-					
To Capital Reserve Fund					
To Exp. Tr. Fund-except #4917					
To Health Maint. Trust Funds					
To Nonexpendable Trust Funds					
To Fiduciary Funds					

**SUBTOTAL 1**

\$1,992,642.00	\$1,904,584.00	\$2,210,390.00	\$0.00
----------------	----------------	----------------	--------

**\*\*SPECIAL WARRANT ARTICLES\*\***

Special warrant articles are defined in RSA 32:3, VI, as appropriations: 1) in petitioned warrant articles; 2) appropriations raised by bonds or notes; 3) appropriation to a separate fund created pursuant to law, such as capitol reserve funds or trust funds; 4) an appropriation designated on the warrant as a special article or as a nonlapsing or nontransferable article.

	2	3	4	5	6	7
Purpose of Appropriations (RSA 32:3,V)	Warrant Article #	Appropriations Prior Year As Approved by DRA	Actual Expenditures Prior Year	Appropriations Ensuing FY (RECOMMENDED)	Appropriations Ensuing FY (NOT RECOM.)	
Road Repairs Capital Reserve	8	\$0.00	\$0.00	\$25,000.00		
Ambulance Capital Reserve	9	\$15,000.00	\$15,000.00	\$15,000.00		
Fire Dept. Equipment Capital Reserve	10	\$15,000.00	\$15,000.00	\$15,000.00		
Police Cruiser Capital Reserve	11	\$10,000.00	\$10,000.00	\$10,000.00		
Highway Eqpt. Rplc. Capital Reserve	12	\$15,000.00	\$15,000.00	\$75,000.00		
Revaluation Capital Reserve	13	\$0.00	\$0.00	\$25,000.00		
Emergency Services Bldg. Capital Reserve		\$15,000.00	\$15,000.00	\$0.00		
Airport Road Bridge Replacement	14	\$0.00	\$0.00	\$500,000.00		
Water Dept. Rep./Rplcmt Expend. Gen. Tr.	16	\$0.00	\$0.00	\$15,000.00		
Water Dept. Phone Line Upgrade	17	\$0.00	\$0.00	\$13,000.00		
WEDC Downtown Rehab.	18	\$0.00	\$0.00			\$100,000.00
Weeks Med. Center, Home Health & Hospice	19	\$10,536.00	\$10,536.00	\$10,852.00		
White Mountain Mental Health	20	\$2,862.00	\$2,862.00	\$2,862.00		
The Caleb Group	21	\$3,300.00	\$3,300.00	\$3,300.00		
Sr. Meals Program	22	\$2,800.00	\$2,800.00	\$2,800.00		
Sr. Wheels/No. Co. Transportation	23	\$3,100.00	\$3,100.00	\$3,500.00		
North Country Home Health	24	\$3,064.00	\$3,064.00	\$3,064.00		
Ammonoosuc Community Health	25	\$2,500.00	\$2,500.00	\$2,500.00		
Littleton Regional Hospital	26	\$0.00	\$0.00	\$2,000.00		
<b>SUBTOTAL 2 RECOMMENDED</b>		<b>XXXXXXXXXX</b>	<b>XXXXXXXXXX</b>	<b>\$723,878.00</b>	<b>XXXXXXXXXX</b>	

**\*\* INDIVIDUAL WARRANT ARTICLES**

	2	3	4	5	6	7
Purpose of Appropriations (RSA 32:3,V)	Warrant Article #	Appropriations Prior Year As Approved by DRA	Actual Expenditures Prior Year	Appropriations Ensuing FY (RECOMMENDED)	Appropriations Ensuing FY (NOT RECOM.)	
Zoll Defibrillators		\$39,400.00	\$37,614.00	\$0.00		
Water Dept. Hydraulic Model		\$6,750.00	\$5,700.00	\$0.00		
Spring Street Repairs/Rehab.		\$61,000.00	\$61,000.00	\$0.00		
Landfill Closure		\$70,000.00	\$69,825.00	\$0.00		
Master Plan Update		\$16,000.00	\$0.00	\$0.00		
Capital Improvements Program	15	\$0.00	\$0.00	\$6,000.00		
<b>SUBTOTAL 3 RECOMMENDED</b>		<b>XXXXXXXXXX</b>	<b>XXXXXXXXXX</b>	<b>\$6,000.00</b>		

2

3

4

5

6

SOURCE OF REVENUE	Warrant Article #	Estimated Revenues Prior Year	Actual Expenditures Prior Year	Estimated Revenues Ensuing Year
<b>TAXES</b>				
Land Use Change Taxes-General Fund		\$12,950.00	\$12,950.00	\$15,000.00
Resident Taxes				
Timber Taxes		\$6,000.00	\$7,547.00	\$10,000.00
Payment in Lieu of Taxes		\$45,000.00	\$44,062.00	\$45,000.00
Other Taxes				
Interest & Penalties on Delinquent Taxes		\$45,000.00	\$45,324.00	\$45,000.00
Inventory Penalties				
Excavation Tax (\$.02 per cu yd)		\$300.00	\$298.00	\$300.00
<b>LICENSES, PERMITS &amp; FEES</b>				
Business Licenses and Permits				
Motor Vehicle Permit Fees		\$325,000.00	\$332,103.00	\$330,000.00
Building Permits				
Other Licenses, Permits and Fees		\$10,000.00	\$26,893.00	\$12,000.00
FROM FEDERAL GOVERNMENT			\$11,076.00	
<b>FROM STATE</b>				
Shared Revenues		\$16,694.00	\$55,236.00	\$16,694.00
Meals and Rooms Tax Distribution		\$89,354.00	\$89,354.00	\$90,000.00
Highway Block Grant		\$61,732.00	\$61,732.00	\$63,978.00
Water Pollution Grant		\$10,770.00	\$10,770.00	\$10,770.00
Housing and Community Development				
State, Federal Forest Land Reimbursement				
State Aid Bridge Grant Program				\$400,000.00
Other (Including Railroad Tax)			\$1,387.00	\$1,387.00
FROM OTHER GOVERNMENTS				
<b>CHARGES FOR SERVICES</b>				
Income from Departments		\$235,000.00	\$248,219.00	\$235,000.00
Other Charges		\$15,000.00	\$8,984.00	\$15,000.00
<b>MISCELLANEOUS REVENUES</b>				
Sale of Municipal Property				
Interest on Investments		\$20,000.00	\$23,061.00	\$25,000.00
Other				
<b>INTERFUND OP TRANSFERS</b>				
From Special Revenue Funds				
From Capitol Project Funds				
From Enterprise Funds				
Sewer (Offset)		\$106,935.00	\$110,361.00	\$126,935.00
Water (Offset)		\$146,800.00	\$160,388.00	\$146,800.00
Electric (Offset)				
Airport (Offset)				
From Capitol Reserve Funds		\$43,332.00	\$43,332.00	\$13,000.00
From Expendable Gen. Trust Fund		\$6,750.00	\$5,700.00	\$0.00
Transfers From Conservation Funds				
<b>OTHER FINANCING SOURCES</b>				
Proc. From Long Term Bonds and Notes				
Amount VOTED From F/B ("Surplus")				
Fund Balance ("Surplus") to Reduce Taxes		\$251,000.00	\$251,000.00	\$200,000.00
<b>TOTAL ESTIMATED REV. &amp; CREDITS</b>		<b>\$1,447,617.00</b>	<b>\$1,549,777.00</b>	<b>\$1,801,864.00</b>

## BUDGET SUMMARY

	Prior Year	Ensuing Year
Operating Budget Appropriations Recommended (from page 4)	\$1,992,642.00	\$2,210,390.00
Special Warrant Articles Recommended (from page 5)	\$98,162.00	\$723,878.00
Individual Warrant Articles Recommended (from page 5)	\$193,150.00	\$6,000.00
TOTAL Appropriations Recommended	\$2,283,954.00	\$2,940,268.00
Less: Amount of Estimated Revenues & Credits from above	\$1,447,617.00	\$1,801,864.00
Estimated Amount of Taxes to be Raised	\$836,337.00	\$1,138,404.00

TOWN OF WHITEFIELD, NH  
TRUST FUNDS REPORT  
AS OF DECEMBER 31, 2007

DATE OF CREATION	NAME OF FUND	HOW IN-VESTED	PRINCIPAL BALANCE BEGINNING YEAR	NEW FUNDS CREATED	TRANS-FER	WITH-DRAWALS	BALANCE END YEAR	INCOME BEGINNING YEAR	INCOME DURING YEAR	EXPENDED DURING YEAR	BALANCE END YEAR	GRAND TOTAL END YEAR
	Revaluation NH-01-0087-7	NHPDIP	\$				\$	\$ 374	\$ 5	\$ 19	\$ 393	\$ 393
1998	Fire Vehicle NH-01-0087-20	NHPDIP	\$ 15,000				\$ 15,000	\$ 4,303	\$ 5	\$ 983	\$ 5,286	\$ 20,286
1988	Sewer Replacement NH-01-0087-1	NHPDIP	\$ 7,000				\$ 7,000	\$ 4,703	\$ 5	\$ 596	\$ 5,299	\$ 12,299
2001	Water Department Repair NH-01-0087-10	NHPDIP	\$ 20,000			\$ 5,700	\$ 14,300	\$ 2,108	\$ 5	\$ 1,021	\$ 3,129	\$ 17,429
2004	Ambulance NH-01-0087-9	NHPDIP	\$ 45,000	\$ 15,000			\$ 60,000	\$ 2,014	\$ 5	\$ 2,401	\$ 4,415	\$ 64,415
2004	Police Cruiser NH-01-0087-19	NHPDIP	\$	\$ 10,000			\$ 10,000	\$	\$ 5	\$ 5	\$ 5	\$ 10,005
12/2001	Highway Equipment Replacement Fund NH-01-0087-16	NHPDIP		\$ 15,000			\$ 15,000	\$	\$ 5	\$ 8	\$ 8	\$ 15,008
12/2001	Ambulance Building Fund NH-01-0087-0017	NHPDIP	\$ 145,000	\$ 15,000			\$ 160,000	\$ 12,922	\$ 5	\$ 8,046	\$ 20,968	\$ 180,968
12/2001	Brown Street Retaining Wall NH-01-0087-18	NHPDIP	\$ 60,000				\$ 60,000	\$ 5,974	\$ 5	\$ 3,358	\$ 9,332	\$ 69,332
12/2002	Fire Department Communications NH-01-0087-8	NHPDIP					\$	\$ 0			\$ 0	\$ 0
12/2002	Industrial Park Infra structure NH-01-0087-12	NHPDIP	\$ 20,000				\$ 20,000	\$ 1,648	\$ 5	\$ 1,102	\$ 2,750	\$ 22,750
12/2005	Land Fill Closure NH-01-0087-11	NHPDIP	\$ 40,000			\$ 40,000	\$ 0	\$ 1,688	\$ 5	\$ 3,332	\$ 0	\$ 0
12/2007	Fire Department Equipment Fund NH-01-0087-0014	NHPDIP	\$ 0	\$ 15,000			\$ 15,000	\$ 0	\$ 5	\$ 8	\$ 8	\$ 15,008
	Totals		\$ 352,000	\$ 70,000	\$ 0	\$ 45,700	\$ 376,300	\$ 35,734	\$ 19,190	\$ 3,332	\$ 51,593	\$ 427,893

DATE OF CREATION	NAME OF FUND	HOW IN-VESTED	PRINCIPAL BALANCE BEGINNING YEAR	NEW FUNDS CREATED	CASH GAWITH-OR (LOSS)DRAWALS ON SECURITIES	BALANCE END YEAR	INCOME BALANCE BEGINNING YEAR	INCOME DURIEXPENDED AMOUNT DURING YEAR	BALANCE END YEAR	GRAND TOTAL END YEAR	
	TOWN OF WHITEFIELD, NH TRUST FUNDS REPORT AS OF DECEMBER 31, 2007										
	Park St Cemetery NH-01-0087-5	NHPDIP	\$ 53,919	\$2,100		\$56,019	\$12,969	3,452	\$16,421	\$72,440	
	Pine St Cemetery NH-01-0087-6	NHPDIP	\$ 39,479			\$39,479	\$40,830	4,088	\$44,918	\$84,397	
	Weeks Family Lot NH-01-0087-4	NHPDIP	\$ 5,000			\$5,000	\$3,886	451	\$65	\$9,272	
5/15/31	Walker/Gove NH-01-0087-3	NHPDIP	\$ 1,500			\$1,500	\$1,465	152	\$1,617	\$3,117	
5/13/49	EH Jordan Library NH-01-0087-3	NHPDIP	\$ 500			\$500	\$517	51	\$568	\$1,068	
8/7/87	M Hamilton Library NH-01-0087-2	NHPDIP	\$ 2,000			\$2,000	\$1,431	175	\$1,605	\$3,605	
3/1/993	Police Scholarship NH-01-0087-13	NHPDIP	\$ 1,943			\$1,943	\$1,249	163	\$1,412	\$3,355	
	Cemetery Association 34213 LNB CD 8030310	LNB CD	\$ 833			\$833	\$433	28	\$461	\$1,294	
7/30/24 CT River	AB White Post Flag SAV Acct 1124224	CR SAV	\$ 100			\$100	\$567	44	\$570	\$670	
	Cemetery Association Putnam Fund	PF	\$ 310			\$310	\$58		\$58	\$368	
	Total Both Pages		\$105,584	\$2,100	\$0	\$107,684	\$63,406	8,562	\$65	\$179,687	
			\$457,584	\$72,100	\$0	\$445,700	\$99,140	\$27,752	\$3,397	\$607,479	
*	Putnam Fund is currently worth \$629.59										
**	NHPD NH-01-0087-8 has a balance of \$0.38										
	NHPDIP is the New Hampshire Public Deposit Pool LNB CD is a CD invested through the Lancaster National Bank CR SAV is a savings account at Connecticut River Bank Catherine Burns 2010 William Jones 2008 Joe Elgoin 2009										



TOWN OF WHITEFIELD, NH TRUST FUNDS REPORT AS OF DECEMBER 31, 2007												
DATE OF CREATION	NAME OF FUND	HOW IN-VESTED	PRINCIPAL BALANCE BEGINNING YEAR	NEW FUNDS CREATED	TRANS-FER	WITH-DRAWALS	BALANCE END YEAR	INCOME BALANCE BEGINNING YEAR	INCOME DURING YEAR	EXPENDED DURING YEAR	BALANCE END YEAR	INCOME GRAND TOTAL END YEAR
Unknown	Fire Truck		\$0				0	\$0	\$0	\$0	\$0	\$0
1993	Cruiser		\$0				\$0	\$0	\$0	\$0	\$0	\$0
1994	Landfill Closure		\$0				\$0	\$0	\$0	\$0	\$0	\$0
1995	Highway Grader		\$0				\$0	\$0	\$0	\$0	\$0	\$0
1995	Fire Truck		\$0				\$0	\$0	\$0	\$0	\$0	\$0
1996	Cruiser		\$0				\$0	\$0	\$0	\$0	\$0	\$0
1996	Highway Equipment		\$0				\$0	\$0	\$0	\$0	\$0	\$0
1996	GIS		\$0				\$0	\$0	\$0	\$0	\$0	\$0
1999	Salt Shed		\$0				\$0	\$0	\$0	\$0	\$0	\$0
2004	Police Cruiser		\$0				\$0	\$0	\$0	\$0	\$0	\$0
2004	Ambulance		\$0				\$0	\$0	\$0	\$0	\$0	\$0

The money in the above Capital Reserve Accounts has been spent but the accounts have not been discontinued



There have been more notable staff achievements in 2007. Receiving their EMT-Basic Certificates were Rick Grima Sr., Amanda St. Martin, and Mike McCarthy.

#### **Fire/EMS Officers**

Fire Chief James Watkins, Assistant Chief Tony Stiles, Captain Robbie Blanchette, Captain Terry Schmidt, Fire Lieutenant Rick Grima Sr., E.M.S. Lieutenant Ann Miller,

#### **Fire/EMS Members**

Sean McAlister, John St. Martin, Zina Schmidt, Barry Page, Keri Mellett, Tom Ladd, Donna Page, Doug Allen, Amanda St. Martin, Mike McCarthy, Lori Comeau, John Wilkinson, Bill Jones, Stephanie Cormier-Mears, Joanna Enman, Kelley Sweeney, Steve Jones, Heather Watkins, Brian Lennox, Steve Marcum, Mark Sodergren, Elwin Greer, Josh Couturier, Arthur Duguay, Dominec D'Arcangelo, Samantha Page, Rick Grima Jr., Jason Marro, Dave Laflamme, Lorna Greer

#### **Explorers**

Brian Glidden, Kassie Houde, Ayla Knapton, Andrew Lowell, Hilliary Schmidt, Adam Smith, Jennie St. Martin.

#### **The following is a breakdown of the calls that were handled for 2007**

E.M.S. Calls:	447
Fire Calls:	117
Service Calls:	66
Non-Emergency Transfers:	48
Total Calls:	678



# Whitefield Police Department

Jefferson Road  
Whitefield, NH 03598  
"Heart of the White Mountains"



William H. Colborn  
Chief of Police

Telephone 837-9086  
Fax 837-9762

2007 brought yet another year of change within the Whitefield Police Department. Sandy Gordon, the Police Department's long time Administrative Assistant, retired and has returned to Nepal for a second time to continue her work with the people of that country. The members of the Whitefield Police Department thank her for her hard work and dedication over the years, and wish her well with her new endeavors.

In October, Patti Rexford was hired to fill the part-time position of Administrative Assistant. Patti has proven to be a great fit within the Police Department and serves the community well. If you have not had the pleasure of meeting Patti, please do not hesitate to stop in and say hello.

It's a sad statement about today's society when there is a need for a Police Officer to be in our schools on a full time basis. Unfortunately, it is obvious that such a need exists, even in the North Country. The job of a School Resource Officer is a unique position within the police profession in that not all officers can succeed. Thankfully, we have Officer Mike Bouton who fills this position for us and does a great job. In 2007 this position was passed within the school budget, and is completely funded by the School District while he is working at the High School.

In reassigning Officer Bouton to the High School, it has left the Police Department short handed. We have tried to get by with part-time officers, but it is very difficult and expensive to find people to commit to the time, cost and liability of becoming a part-time officer, for very little pay in return. We have also lost several part-time officers to full-time employment or who are just getting out of the profession completely. It is for this reason we are asking the town to replace Officer Bouton's position on the streets. Hiring one full-time officer will actually be more cost effective than attempting to hire and train several part-time officers. Not only is this needed for the daily coverage of town, but needed to cover shifts if there is anyone out sick, training or simply taking a day off. Many times we are forced to pay a full-time officer overtime wages or go without any coverage at all. Requesting to fill this position is in no way an attempt to make the Whitefield Police Department a 24-hour department; we are merely attempting to continue coverage in the most effective and economical way possible. The Whitefield Police Department has been funded to have four full-time officers working on the "streets" since the 1991 town meeting, and with the towns approval it is our hope to get back to that level.

On a bright note, through a lot of hard work and dedication by all members of the Whitefield Police Department, we had an exceptional year in solving crimes committed in the town of Whitefield. Of the sixteen reported burglaries, thirteen of them were solved. This included the guns stolen from the Village Gun Store and numerous break-ins of homes and camps in Whitefield and surrounding towns. In fact several of these burglaries were solved before the owners had become aware that they had been burglarized.

The following are general statistics provided for informational purposes for the year 2007.

Accidents	70
Arrest	80
Criminal Investigations	152
Miscellaneous Services	686
Motor Vehicle Summons	125
Motor Vehicle Warnings	939

The Whitefield Police Department is committed to community policing and being a proactive, positive entity within the town of Whitefield. To this end, we continue to ask for your help in protecting our way of life in the north county, by reporting crimes and suspicious or criminal activity when you see it.

Respectfully Submitted



William H. Colborn  
Chief of Police



## 2007 Planning Board News

At the March 2007 Town Meeting voters authorized an update of the Town's 1989 Master Plan. The purpose of the Master Plan is to guide Whitefield's future growth starting with a community attitude survey followed by a vision statement summarizing the desires of the residents of Whitefield. Through a formal request for proposal process, Tara Bamford of North Country Council was retained to help us develop the Plan. The Board of Selectmen appointed members of a master plan steering committee whom helped put together the survey. The survey was sent out to all voters on the checklist and/or those who own property in Whitefield. We received a statistically valid response, including 35 pages of single spaced comments. The survey response showed that residents, whether full or part-time care deeply about Whitefield and its future. A copy of the survey summary is available at the Town Clerk's office and at the Library. Below please find a set of statements which we feel articulate the desires of Whitefield's residents. These statements will be used as the guiding principles and priorities to implement the vision in the form of land use planning, regulations, and initiatives which the Town as a whole can take. We hope to complete the Master Plan by last summer and bring specific recommendations to you for your approval at the March 2009 Town Meeting. All our meetings are warned, and we always invite your comments and feedback.

Whitefield envisions a future where:

- Growth has been slow and well managed with impacts on services carefully examined to keep taxes down.
- Community spirit continues to shine through in the stewardship of natural and cultural treasures.
- The common area is a vibrant walkable mixed use area attractive to residents and visitors with buildings in good repair and thriving businesses appropriate for a village center.
- The Town's lakes, wetlands, and other important habitat areas are protected from the negative impacts associated with poorly planned development.
- The small Town atmosphere remains; residents continue to rely on nearby communities for major shopping.
- The businesses that have come to Whitefield pay a livable wage for residents; and those that have come to Whitefield have had a positive impact on the tax base.
- The transportation system serves the needs of businesses, commuters, and residents of all ages, including those that do not drive.
- The bandstand and town office have been restored as gems of the community.
- The scenic views of the mountains from various points in town remain an important element in the quality of life.

Finally, we would like to thank Stephanie Glidden, Town Clerk, for her help throughout the year in addressing resident's questions and in preparing Planning Board minutes. It is

hoped that in the future, approved Planning Board minutes will be on the Town's website.

**Members of the Master Plan Committee include:**

Chris Diego  
Bill Robinson  
Dick Mallion  
Sam Chase  
Roger Croteau

**And Planning Board Members**

Courtney Vashaw-Piper  
Duane Hall  
Frank Lombardi  
Scott Burns  
Everett Kennedy  
Ed Betz

## Whitefield Conservation Commission Report for 2007

The Whitefield Conservation Commissioners are Charlie Baylies, Rita Chadwick, Jacki Comeau, Marjorie Goodson, Bill Thompson, and Dick Mallion. Meetings are usually scheduled every other month on the third Wednesday at 7:00 PM and are held in the Town Office. Meeting notices are posted on the bulletin board in the Town Office, and public attendance and input is encouraged.

During 2007, the Commission worked with numerous landowners seeking wetlands permits needed before doing work on their properties. Early involvement of the Commission meant that all the applications were approved, although some of them took a few months because of the workload at the Department of Environmental Services. Landowners are encouraged to get the Commission involved as soon as the need for a project is evident. Application forms can be obtained at the Town office or online at the DES website.

A new requirement this year is a check with the NH Natural Heritage Bureau as part of the application process. This can also be done online and, in most cases, there is no extra fee charged.

The Natural Resource Inventory is being used as input to the Town's master planning revision that is underway. Active involvement of the Commission Chair on the Master Plan Advisory Committee will ensure that the environmental aspects of Whitefield that make it such a nice place to live are considered as the plan is developed by the Planning Board.

The Commissioners are all well trained in their duties and are willing to answer questions, make field visits, assist in filling out applications, or do anything else to make it possible for landowners to what they want to do on their property while staying within the environmental regulations of Whitefield, New Hampshire, and the United States.

Anyone needing to contact the Whitefield Conservation Commission can do so through the Town Office, or you may call the Chair, Dick Mallion, at 837-9732.

## Whitefield Economic Development Corporation

The Whitefield Economic Development Corporation was founded in the 1980's to promote economic development in the Town. Our activities have generally been reactive, responding to inquiries from companies interested in locating in the Whitefield area.

In 2007, we became involved in looking at the center area of Town, the area surrounding the Common. Residents are concerned with the condition of some of the buildings in this area, and the general downtrodden appearance. Something needed to be done to revitalize this area to attract businesses, resulting in more people coming to town.

Two of our meetings were devoted to discussing the problems seen in this area and identifying actions that could be taken to make this area more vibrant. At another meeting, Margaret Corey presented a number of pictures that she had taken in this area showing things that had deteriorated and in need of repair. Many of these problems appeared to be fixable without major effort, just the interest and involvement on the part of residents and businesses.

Many ideas were presented at these meetings and it was decided that this information should be passed on to the Master Plan Update Committee to be looked in the new master plan.

We are hopeful that a new business will soon be locating at the Industrial Park. We are waiting for the purchase of the land to be finalized.

Another company is interested in a piece of land adjacent to the Industrial Park as the site for a manufacturing plant that could eventually employ 240 people. Whitefield is one of five sites across the country being considered for this plant.

This year we will be updating the Town brochure, and working with Ron Littlefield to make the Town website more inclusive to include meeting minutes, agendas, etc. The goal is to make the website a place where residents can go to get needed information as well as being a place for visitors to get an insight into the Town.

The Whitefield Economic Development Corporation meets quarterly, generally on the third Wednesday of the month, in the Town Office at 7:00 pm. The next meeting will be on April 16, 2008. We invite all people interested in economic development in Whitefield to attend our meetings.



## Common Committee

The year 2007 was quite successful for the Common Committee.

After our usual spring plantings were done on the Common, we were told that the star on the top of the Bandstand could not be retrieved due to the instability of the roof. That led to an inspection by knowledgeable contractors and Ed Betz. It was discovered that extensive repairs and painting were required as soon as possible.

Thus, the "Save the Bandstand" Fund was born, and was very successful. Members of the Common Committee, and Roy Birard and Bob Herman from the Veterans of Foreign Wars Post worked within the community to raise funds needed to complete the work on the Bandstand.

More studies were done and it was decided to proceed with certain work on the base that was required before winter came. We were able to do this because successful fundraising efforts provided the monies to accomplish this segment of the project.

Added to this, the Common Committee submitted a grant request to the Neil and Louise Tillotson Fund of the New Hampshire Charitable Foundation- North Country, and were notified just before Christmas that the requested \$4,700.00 had been granted for extensive repair to the Bandstand..

The remainder of the work will be completed this spring, and even some more essential needs will be tended to.

Thank you to all who contributed to this fund, to the Neil and Louise Tillotson Fund of the New Hampshire Charitable Foundation, and to the Town.



## Contributors to the "Save the Bandstand" Fund

Daniel & Mary Ahern	Stephen & Rowena Donohue	Lise Moran
American Legion Post 41	Matt & Anna Doyle	The Morrison
Susan Argetsinger	Carlene Dumas	John & Diane Mumley
Jim & Diane Ash	Eric & Judy Feldmann	Joseph & Dorothy Murdoch
Joseph & Claire Ashe	Bob & Ann Gary	Gibbs Murray
Mark & Dawn Bechtold	Robert & Bobbie Gaudes	Ashley Nevers
Bob & Claire Beckler	Leon & Sharon Geil	David & Jane Peth
Elizabeth Brooks	Hilltop Marketplace	Presby Environmental
Burns Enterprises	Frieda Hodgkinson	Sara Roy
Burns Insurance Agency	Elizabeth Hubbard	Ken & Margaret Russell
Joe Cabaup	George & June Jones	Don & Melon Sanders
Arthur & Beverly Chabot	Wendy Jossefy	John & Roxie Severance
Aggy Chase	Bunny Kelz	Sherwin-Williams Company- Berlin
Ed & Nancy Chase	Peter & Anne Labbe	Donald Spalding
Mary Jane Chase	Laconia Savings Bank	Dave & Tanya Tellman
Robert Chase	Lancaster National Bank	Brad & Bee Thayer
Common Committee	Dave & Joan LeBaron	Douglas & Beverly Tomb
Common Ground	Cathie Lewis	Neil & Louise Tillotson Fund
David & Elaine Dana	Ron & Carol Littlefield	Lavina Tomb
Lewis & Foncie Darby	Mac's Market	Village Gun Store
Tom & Annie Devon	Richard & Muriel Mahn	V.F.W. Post 10675
DG Whitefield	Frank & Linda Mai	Whitefield Circle
Tim & Hileen Dieterich	Linda McLaughlin	Whitefield Economic Development
John Dodge	James J.D. Moran	Whitefield Historical Society
Lore Dodge	John B. Moran III	Whitefield Senior Chorus

### Memorial Gifts

Jacqueline Bagley & Demetrius Bagley in memory of Myrtle Bagley

Mr. & Mrs. Raymon Gregoire in memory of Helen Brooks

Donations were also received in donation buckets at:

- Pancake Breakfasts
- Information Booth
- Town Office

In-kind services were provided by the following:

- Ed Betz- Engineering
- Aggy Chase
- Mary Jane Chase- Thank You Cards
- Karen Philbrook- Copying
- Don Sanders- Copying
- Town of Whitefield

We apologize for any omissions.

## *WHITEFIELD RECREATION DEPARTMENT*

Hello All!

My name is Kelly Smith. I was hired as the Whitefield Recreation Director in April of 2007. I am no stranger to the Recreation Department as I ran the summer program in 2004. I am delighted to be back doing all the tasks of the director's position.

The Whitefield Recreation Department has conducted many events in 2007. We had a successful Community Day in August and a Fall Festival in October. Both events are geared for both adults and children with activities and vendors.

The 2007 Summer Program had many changes this year. I added additional swimming 2 times a week at the Colonel Town Pool in Lancaster. We also had Junior Campers attend, which were students who had completed grade 6 and 7. I am looking forward to planning a super 2008 Summer Program.

Baseball, soccer, and basketball were all organized for the 2007 year. Unfortunately, basketball only was available to K-2 students due to lack of coaches. We need more parents to help with coaching or our programs will not be able to run. The 2008 baseball season is approaching and hopefully we can be successful in having coaches for all age groups.

Thank you to all the parents who have **VOLUNTEERED** their time to be coaches for our children of Whitefield! You are appreciated!

Sincerely,  
Kelly Smith  
Whitefield Recreation Director

Whitefield Public Library  
Librarian's Report

This summer, the New Hampshire Library Trustee's Association celebrated its 50<sup>th</sup> anniversary. As part of the celebration, Whitefield was chosen to host a great program. "Andrew Carnegie," professionally portrayed by Professor Jeffrey Smith of Missouri, took place at the C.D. McIntyre auditorium in July. The audience was treated to an entertaining 2-hour one-man show. Our own Carnegie library, built in 1904, was the reason Whitefield was chosen as one of the four towns in NH for this event.

Summer also brought a successful Summer Reading Program. 36 children read 393 books, and 20 won prizes for their efforts. The annual Book Sale venue was changed this year to the Town Hall, and took place during Community Day. The convenience, indoor location, and the large amount of people in town made for a very successful sale. We will continue to have the Sale during that same time next summer.

It has recently come to mind that the "value" of a library card may not generally be considered by our patrons. All, hopefully, appreciate the entertainment, education, and information made possible by using the library. Given the average cost of books, movies, magazines and books-on-tape, we have figured that a family's "pile" of borrowed library materials for one week can easily equal \$300.00! (Average costs: hard-cover novels are \$27; paperbacks \$10; children's books \$17; DVD's \$20; magazines \$4; books-on-tape \$35.). What a bargain for tax-payers!

Use of our public access computers almost doubled this year. Our Gates Grant computers are still going strong and have thus far proven to be trouble-free. Tourists and local residents alike make use of our high-speed Internet access.

In 2007, Coos Quilters (whose Quilt Raffle donation increases our book budget yearly), Writers Group, and Whitefield Historical Society made use of our meeting room. We could not operate the library without our valuable staff members: Margaret O'Donnell, Karen (Murray) Gordon, and Linda Stock.

Respectfully submitted,  
Sandy Holz, Librarian

Whitefield Public Library

Librarian's Report

	2006	2007
Circulation	9058	9558
Accessions	594	583
Adult Fiction by Gift	35	11
Adult Fiction by Purchase	228	290
Juvenile Fiction by Gift	1	26
Juvenile Fiction by Purchase	131	97
Adult Non-Fiction by Gift	16	38
Adult Non-Fiction by Purchase	43	16
Juvenile Non-Fiction by Gift	5	0
Juvenile Non-Fiction by Purchase	33	6
Records/Cassettes	60	48
Video Cassettes	42	51

WHITEFIELD PUBLIC LIBRARY

**Beginning Balance Jan. 1, 2007**

**\$ 9,869.52**

**REVENUE:**

Town Appropriation	\$ 33,500.00
Fines	535.35
Copies	77.55
Gifts & Donations	4,462.99
Book Sale	774.50
Interest	7.48
Computer Printing	174.30

**Total Revenue:** **\$ 39,532.17**

**EXPENDITURES:**

Payroll	\$ 12,562.27
Books	7,041.87
Magazines	863.60
Videos	995.96
Treasurer	500.00
Heat	2,057.95
Electricity	700.13
Telephone/Internet	1,013.60
Payroll Tax	961.06
Repairs & Maintenance	1,472.50
Programs & Supplies	651.25
Misc.	375.00
Investment Pool & Savings	4,368.00

**Total Expenditures:** **\$ 33,563.19**

**Ending Balance Dec. 31, 2007**

**\$ 15,838.50**

**NH Public Deposit Investment Pool and Savings Accounts:**

Handicap Access Fund	\$ 124,693.36	
Women's Study Club	1,856.99	
Jonna's Fund	2,557.56 (PDIP)	\$ 82.40 (Savings)

**Respectfully Submitted: Kathleen S. Dunlap, Treasurer**

**www.whitefieldnh.org**

**P. O. Box 276 ~ Whitefield, NH 03598**

**Email: [info@whitefieldnh.org](mailto:info@whitefieldnh.org)**

February 1, 2008

Greetings from Whitefield! Make that [www.whitefieldnh.org](http://www.whitefieldnh.org), actually.

Finally, after nearly three years of good intentions and many obstacles, we have revitalized the website for Whitefield, New Hampshire USA and are prepared to go forward with regular updates.

**In order to make this a great community website we are seeking your input.** One of the features of the website is the free listing of public events or events sponsored by and for non-profit groups, organizations, etc... We ask that you provide us with information about upcoming events or activities that you would like publicized in a timely manner so we may list them on the calendar located on the website's home page. We invite you to share any information you wish that would be of general community interest.

We also want you to know that the website is privately owned and maintained 100% by privately donated funds. **Not one dime of your tax money goes toward this website.** The not-for-profit website offers advertising opportunities for those interested and 100% of all proceeds from advertising are deposited directly into the *Joan R. Blechl* NEIGHBORHOOD FUND. This 501(c)3 fund was established to help people and animals in need right here in our local neighborhoods. So far, the fund has contributed to several families suffering financial strain as a result of severe medical crises; families without insurance who lost their homes to fire or other catastrophe; animals rescued from abusive and neglectful situations; north country food pantries with dwindling inventory and much more.

**Please contact us with information about the events and activities you'd like publicized for free.** You may also contact us if interested in placing an ad on the website (non-profits may be listed for free in one directory and display ads are charged at half-price). Sorry—no political ads allowed.

You may have questions. Please—by all means—feel free to call and ask whatever is on your mind. We can be reached Monday through Friday at our office in Littleton at 444-5100, extension 303. You may also e-mail to [info@whitefieldnh.org](mailto:info@whitefieldnh.org). Thank you!

Sincerely,

*Ron and Carol*

Ron and Carol Littlefield  
[www.whitefieldnh.org](http://www.whitefieldnh.org)

## Report of Forest Fire Warden and State Forest Ranger

Your local Forest Fire Warden, Fire Department, and the State of New Hampshire Division of Forests & Lands work collaboratively to reduce the risk and frequency of wildland fires in New Hampshire. To help us assist you, please contact your local Forest Fire Warden or Fire Department to determine if a permit is required before doing **ANY** outside burning. Under State law (RSA 227-L:17) a fire permit is required for all outside burning unless the ground is completely covered with snow. The New Hampshire Department of Environmental Services also prohibits the open burning of household waste. Citizens are encouraged to contact the local fire department or DES at 1-800-498-6868 or [www.des.state.nh.us](http://www.des.state.nh.us) for more information. Safe open burning requires diligence and responsibility. Help us to protect New Hampshire's forest resources. For more information please contact the Division of Forests & Lands at (603) 271-2214, or online at [www.nhdfl.org](http://www.nhdfl.org).

Fire activity was very busy during the spring of the 2007, particularly late April into early May. As the forests and fields greened up in later May the fire danger decreased. However, a very dry late summer created very high fire danger again from August into September, with fire danger reaching very high on Labor Day weekend. Even with the dry conditions, the acreage burned was less than half that of 2006. The largest forest fire during the 2007 season burned approximately 26 acres on the side of Wantastiquet Mountain in Chesterfield during the month of May. Our statewide system of 16 fire lookout towers is credited with keeping most fires small and saving several structures this season due to their quick and accurate spotting capabilities. Many homes in New Hampshire are located in the wildland urban interface, which is the area where homes and flammable wildland fuels intermix. Several of the fires during the 2007 season threatened structures, a constant reminder that forest fires burn more than just trees. Homeowners should take measures to prevent a wildland fire from spreading to their home. Precautions include keeping your roof and gutters clear of leaves and pine needles, and maintaining adequate green space around your home free of flammable materials. Additional information and homeowner recommendations are available at [www.firewise.org](http://www.firewise.org). Please help Smokey Bear, your local fire department and the state's Forest Rangers by being fire wise and fire safe!

### 2007 FIRE STATISTICS

(All fires reported as of November 8, 2007)

(figures do not include fires on the White Mountain National Forest)

COUNTY STATISTICS		
County	Acres	# of Fires
Belknap	30	95
Carroll	11	53
Cheshire	44	36
Coos	6	15
Grafton	4	30
Hillsborough	61	71
Merrimack	16	73
Rockingham	16	22
Strafford	19	32
Sullivan	5	10

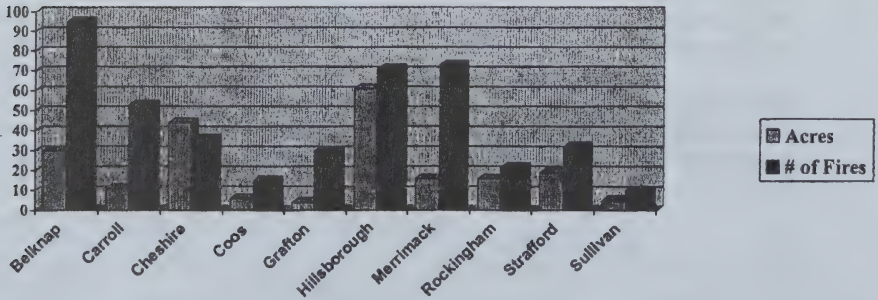

### CAUSES OF FIRES REPORTED

		Total Fires	Total Acres
Arson	5	2007	437
Debris	197	2006	500
Campfire	38	2005	546
Children	22	2004	482
Smoking	41	2003	374
Railroad	5		
Equipment	3		
Lightning	7		
Misc.*	119		

(\*Misc.: power lines, fireworks, electric fences, etc.)

**ONLY YOU CAN PREVENT WILDLAND FIRE**





## Raymond S. Burton

338 River Road  
Bath, NH 03740  
Tel. (603) 747-3662  
Car Phone: (603) 481-0863  
E-mail: ray.burton4@gte.net

December 27, 2007

*Executive Councilor  
District One*

### **Report to the People of District One By**

**Ray Burton, Councilor District One**

It is a pleasure to serve this large northern district of 98 towns, 4 cities, and 5 counties with a population of 247,000 people. The Executive Council is at the top of your Executive Branch of NH State Government. The Governor and Executive Council appoint 352 Commissions and Directors who administer NH law and budget as prescribed by the NH House and Senate.



*Towns in Council District #1*

#### **CARROLL COUNTY:**

Albany, Bartlett,  
Chatham, Conway, Easton,  
Effingham, Freedom, Hart's Loc,  
Jackson, Madison, Moultonborough,  
Ossipee, Sandwich, Tamworth,  
Tuftonboro, Wakefield, Wolfeboro

#### **GRAFTON COUNTY:**

Alexandria, Ashland, Bath,  
Benton, Bethlehem, Bridgewater,  
Bristol, Campton, Canaan,  
Dorchester, Easton, Ellsworth,  
Enfield, Franconia, Grafton,  
Groton, Hanover, Haverhill,  
Hebron, Holderness, Landaff,  
Lebanon, Lincoln, Lisbon,  
Livermore, Littleton, Lyman,  
Lyme, Monroe, Orange, Orford,  
Piermont, Plymouth, Rumney,  
Sugar Hill, Thornton, Warren,  
Waterville Valley, Wentworth,  
Woodstock

#### **BELKNAP COUNTY:**

Alton, Belmont, Center Harbor,  
Gifford, Laconia, Meredith,  
New Hampton, Sanbornton, Tilton

#### **COOS COUNTY:**

Berlin, Carroll, Clarksville,  
Colebrook, Columbia, Dalton,  
Dixville, Drummer, Errol,  
Gorham, Jefferson, Lancaster,  
Milan, Millsfield, Northumberland,  
Pittsburg, Randolph, Shelburne,  
Stewartstown, Stark, Straford,  
Whitefield

#### **SULLIVAN COUNTY:**

Charlestown, Claremont,  
Cornish, Croydon, Grantham,  
Newport, Plainfield, Springfield,  
Sunapee

2008 is the year to keep an eye on and follow the progress of the NH Transportation Plan. The recommended projects in the highway and bridge plan can be accomplished with existing revenue from the state gasoline tax, bonds and matching federal funds. The Executive Council held public hearings on the projects throughout the state and forwarded their recommendations to Governor Lynch. Governor Lynch will review our recommendations and then submit his recommended plan to the NH House and Senate by January 15<sup>th</sup>, 2008. Without any new revenues for additional projects we will be lucky to maintain the existing state highway and bridge system. If more work is desired than new revenues will have to be voted by the Members of the House and Senate and signed by the Governor. Contact your local legislators- House and Senate. Find them by going to [www.nh.gov](http://www.nh.gov)

This large northern district needs more people on state mandated volunteer boards and commissions. Send your letter of interest and resume to my office, or to Kathy Goode, Director of Appointments/Liaison to the Council, Governor's Office, State House, 107 North Main Street, Concord, NH 03301. Tel. (603) 271-2121. To find out what openings are available and to see a list of boards, visit the NH Secretary of State website at [www.sos.nh.gov/redbook/index/htm](http://www.sos.nh.gov/redbook/index/htm).

I have available from my office informational items about the NH Executive Council, NH Constitution, NH Tourist Map, 2007 Consumer Handbook, and District Maps. IF you would like to receive my Monday morning report by e-mail please send an e-mail address to [rburton@nh.gov](mailto:rburton@nh.gov).

It is an honor to continue to serve you in my now 30 years as a public servant. Contact my office anytime about your ideas, concerns and problems with state government. I respond to all inquiries and challenges.

Sincerely,

**MOUNT WASHINGTON REGIONAL AIRPORT**  
Airport Road, Whitefield

mail c/o Town of Whitefield  
7 Jefferson Road  
Whitefield, NH 03598

Dear Whitefield Neighbors,

This past year, 2007, was a busy one for the airport in Whitefield. Despite record-high aviation fuel prices (nearly \$5.00 a gallon,) we still saw an increase in visitors over the previous year. Fuel sales—the primary source of revenue and a key financial indicator—were up slightly.

We experienced a significant increase in “business class” aircraft traffic—slightly more than 200 operations, which was nearly double the number in 2006. A majority of these flights brought folks to the two grand hotels. But a significant number of business travelers also came to the region for other reasons—primarily related to real estate development and local manufacturing operations. Of course, in advance of the 2008 primaries, we also saw significant traffic from Presidential candidates and their staff. We also saw more than 375 other visitors—those arriving in smaller, personal planes. And our 20 or so local pilots, including local business owners, also used the airport regularly, for recreation and for business purposes.

The work our all-volunteer airport leadership has taken on over the past several years and the work we’ve done to bring jobs and development to the region are the foundation for our recent successes. This foundation is strengthened by the support we receive from our communities—financially and otherwise.

We were able to give back a little to you this year. This summer, for instance, we hosted an airport day—free food, a chance for our neighbors to learn more about the airport and, best of all, free airplane rides. More than 100 of you stopped by; we were glad to meet you all—from the youngest to the most seasoned.

Later in the summer, we treated many of you to a spectacular display of skydiving excitement. Our friends from the east—Maine, to be specific—returned to Mount Washington Regional Airport for a day of jumps and aerobatics, capped off by a trip to one of our local hotels for some après-jump socialization.

We continue to host the local chapter of the Civil Air Patrol, which works with area youth to introduce them to aviation and to train them to be an important part of our disaster response network here in Whitefield and the North Country.

[www.mountwashingtonairport.com](http://www.mountwashingtonairport.com)

The airport also introduced more people to the region through fly-ins held during the summer. We continue to get rave reviews from our visitors, who heap praise on both the airport, itself, and our volunteer-built terminal, as well as the beauty and friendliness of our local communities. That's you! Thanks.

This past fall, we broke ground on a project to develop a parallel taxiway at the airport, which will provide a significant level of added safety for aircraft on the ground. Studies are also underway for design of a precision instrument landing system that will make the airport one of just a few in northern New England to have such technology. This system will, as other projects we've undertaken over the past several years, provide a better safety margin for all aircraft landing at our airport, particularly in adverse weather conditions—something that occurs regularly here.

In spite of higher costs, our efforts to boost revenue through fuel sales, user fees and dedicated volunteer involvement—by pilots and non-pilots, alike—have allowed us to continue building this important part of our transportation infrastructure in a responsible manner. We've been able to pay down debt and set aside funds—which got \$40 or so in Federal matching money for each local dollar invested—for ongoing airport improvements. Through frugal management we ended the year with a modest surplus, which will be used to help fund 2008 operations.

Over the past several years, we've worked hard to do more at Whitefield's airport with less from the town. In the years leading up to the major runway reconstruction and expansion, the town budget included appropriations often in the \$14,000-\$18,000 range. The airport also received nearly \$5,000 in lease money from a business operating on property the airport released for economic development; this stopped when the town sold the property.

Today, we're facing increased costs to operate the snow removal equipment we purchased largely with grant money from the FAA and State. Fuel costs are up for us, just as they are for everyone. Maintenance costs are increasing, as well, as the equipment is aging. Because airport volunteers clear the runway, taxiways, ramps—and even driveways at the airport, we've not had to rely on our local road crew for this, which has saved the town thousands and thousands of dollars in fuel and labor costs.

We're also continuing to secure grants and do work to improve airport infrastructure, funding the sponsor's share, which used to fall to the town, out of our operating budget. Increased fuel sales have helped in this, as have donations, hangar rentals and other fees collected from airport users. A key objective in our next project is to encourage private hangar investment on the property. Work done over the past several years was followed by the addition of two hangars, which contribute more than a third of the \$13,500 or so in property taxes the town collects from building owners at the airport each year.

With increased fuel costs, we'll need to promote the airport more aggressively than ever. We have a terrific facility and a wonderful region. With some targeted advertising and some marketing partnerships—which cost money—we'll work to maintain or even increase travel to the area.

A recent airport inspection has identified trees off-site that are beginning to encroach on air safety zones. The sooner we can address these, the less it will cost us to remove them. But it will cost money, regardless of when we do the work. Our goal is to address it sooner, as funds allow, rather than later.

Another item on the docket for 2008 is developing plans to bring a jet fuel facility to the airport. We already have jets using the airport. What happens, though, is they land, drop off passengers, fly to another airport (generally south or west) to fuel up, then return to Whitefield to pick up their passengers. Our ability to offer jet fuel will not only allow us to serve these guests better, but also will allow us to increase revenue.

All of these items we face are in addition to across-the-board increases in costs for such things as mowing, maintenance, fuel, electricity and more.

With our \$12,000 request, we respectfully ask the townspeople to recognize and affirm the hard work our volunteers—from Whitefield and from neighboring towns—have done to maintain and improve your airport, boost traffic and build for the future of the North Country.

We look forward to continuing to develop the facility. We welcome your comments. And we encourage you to get involved with us as we work to make the airport a stronger part of our region's economy and future.

I sincerely thank you for your ongoing trust and support. Together, we can work to build a more vibrant and accessible North Country in 2008 and beyond.

Respectfully yours,

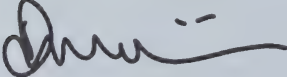

David Willis  
Volunteer Chairman

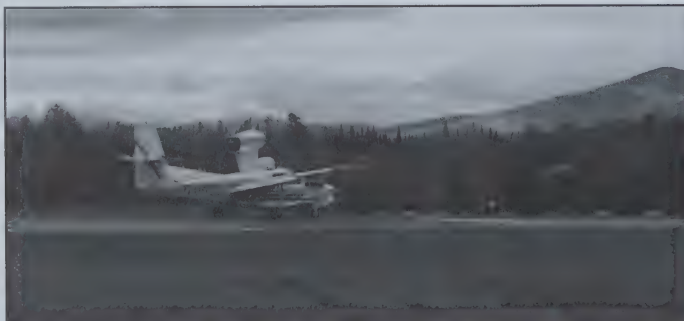

**Mount Washington Regional Airport**  
**Profit & Loss**  
 January through December 2007

	<u>Jan - Dec 07</u>
<b>Ordinary Income/Expense</b>	
<b>Income</b>	
Contributions Income	4,176.00
Courtesy Van Contributions	30.00
Fuel Sales	63,132.80
Hangar Leases	5,103.73
Hangar Space Rental	1,335.00
Hay	250.00
Miscellaneous Income	1,175.00
Sales	20.00
State Appropriations	575.99
Tie Down Fees	471.00
Town Appropriations	18,175.75
<b>Total Income</b>	<b>94,445.27</b>
<b>Cost of Goods Sold</b>	
Cost of Goods Sold	45,363.59
<b>Total COGS</b>	<b>45,363.59</b>
<b>Gross Profit</b>	<b>49,081.68</b>
<b>Expense</b>	
Bank Service Charges	1.00
Capital Projects- MWRA Share	16,008.04
Courtesy Van Expenses	876.92
Credit Card Processing Fees	1,749.53
Depreciation	1,481.11
Dues & Subscriptions	25.00
Interest Expense	2,178.09
Licenses and Permits	18.00
Maintenance & Supplies	2,868.71
Marketing & Promotion	575.00
Postage and Delivery	64.80
Telephone	1,042.52
Travel & Entertainment	1,068.00
Utilities	6,169.42
<b>Total Expense</b>	<b>34,126.14</b>
<b>Net Ordinary Income</b>	<b>14,955.54</b>
<b>Other Income/Expense</b>	
<b>Other Expense</b>	
Fuel Farm Loan Principal	2,706.00
Terminal Bldg. Loan Principal	5,746.00
<b>Total Other Expense</b>	<b>8,452.00</b>
<b>Net Other Income</b>	<b>-8,452.00</b>
<b>Net Income</b>	<b>6,503.54</b>

# Mount Washington Regional Airport Profit & Loss Budget Overview

January through December 2008

	Jan - Dec 08
<b>Ordinary Income/Expense</b>	
<b>Income</b>	
Contributions Income	1,500.00
Courtesy Van Contributions	70.00
Fuel Sales	62,984.00
Hangar Leases	5,104.00
Hangar Space Rental	1,320.00
Hay	250.00
Miscellaneous Income	600.00
State Appropriations	600.00
Tie Down Fees	425.00
Town Appropriations	
Town Of Dalton	695.00
Town Of Franconia	693.00
Town Of Jefferson	840.00
Town Of Lancaster	2,460.00
Town Of Littleton	4,388.00
Town Of Whitefield	12,000.00
Town Appropriations - Other	100.00
<b>Total Town Appropriations</b>	<b>21,176.00</b>
<b>Total Income</b>	<b>94,029.00</b>
<b>Cost of Goods Sold</b>	
Cost of Goods Sold	49,085.00
<b>Total COGS</b>	<b>49,085.00</b>
<b>Gross Profit</b>	<b>44,944.00</b>
<b>Expense</b>	
Brush Clearing & Grounds Maint.	2,000.00
Capital Projects- MWRA Share	16,875.00
Courtesy Van Expenses	900.00
Credit Card Processing Fees	1,449.00
Depreciation	1,481.00
Dues & Subscriptions	50.00
Interest Expense	1,848.00
Licenses and Permits	50.00
Maintenance & Supplies	3,000.00
Marketing & Promotion	2,400.00
Postage and Delivery	72.00
Professional Fees	
Legal Fees	500.00
<b>Total Professional Fees</b>	<b>500.00</b>
Repairs	900.00
Telephone	
Verizon	1,020.00
<b>Total Telephone</b>	<b>1,020.00</b>
Travel & Entertainment	750.00
Utilities	8,815.00
<b>Total Expense</b>	<b>42,110.00</b>
<b>Net Ordinary Income</b>	<b>2,834.00</b>
<b>Other Income/Expense</b>	
<b>Other Expense</b>	
Fuel Farm Loan Principal	2,835.00
Terminal Bldg. Loan Principal	692.00
<b>Total Other Expense</b>	<b>3,527.00</b>
<b>Net Other Income</b>	<b>-3,527.00</b>
<b>Net Income</b>	<b>-693.00</b>

## Northern Gateway Regional Chamber of Commerce Town Report

The Northern Gateway Regional Chamber of Commerce continues to grow bringing in a diversity of members from all 11 towns that we represent.

Our dynamic new website [www.northerngatewaychamber.org](http://www.northerngatewaychamber.org) allows updates to be done in-house, and allows visitors to enter their email address email news and such. This new webpage has greatly increased our number of visitors.

We will be combining the Gateway to the Great Northwoods, a 30 page publication designed to draw tourists to our area with our Relocation Guide, which features a comprehensive guide to the goods and services available in our area. This new publication will be distributed throughout the country to welcome centers, hotels, dining and recreational establishments, local realtors and Town Offices. It is also available on our web page.

Partnering with other organizations and events made EXPO 07 the best business and recreation exposition to date. EXPO 07 was well attended by exhibitors, residents and visitors.

The towns of Lancaster, Jefferson, Whitefield, Dalton, Northumberland, Stark, Stratford, and Randolph New Hampshire, and Gilman, Guildhall, and Lunenburg, Vermont are well represented by the Board of Directors and committee members.

Our funding comes from membership dues, fundraising activities, and town appropriations. Continued support through these resources ensures that we are able to market and therefore grow our local businesses.

As always, we thank the towns, local businesses and residents for their continued support.

Respectfully submitted,

Board members: Sally Pratt, Jackie McKenna, Dru Skora, John Severance, Cindy Normandeau, Linda Hutchins, Barry Normandeau, Brian Emerson, Don Mooney, Tom McCorkhill, Eric Huddleston, Marilyn deLozier, Director.

# TRI-COUNTY COMMUNITY ACTION PROGRAM

30 Exchange Street, Berlin \* 73 Main Street, Lancaster

February 6, 2008

Whitefield Town Office  
Whitefield, NH 03598

To Whom It May Concern:

Tri-County Community Action is requesting **\$2500.00** in funding from the Town of Whitefield to help support its Community Contact Program. Community Contact is the field services arm of the Tri-County CAP. Our purpose is to assist low-income, elderly and handicapped persons to solve problems and meet their physical and financial needs. We accomplish this by providing information, counseling, referrals, budget counseling, guidance and organizational assistance and by effectively linking households with CAP assistance programs and using community resources.

Below is a breakdown of assistance that the CAP Community Contact office provided to Whitefield residents over the last year:

	<u>HOUSEHOLDS</u>		<u>DOLLAR AMOUNTS</u>
Fuel Assistance 2007	322	\$	75,260.00
Weatherization 2006-2007	2	\$	5,872.00
Food Pantry (Average 10 households@ month over the program year)	0		
Electric Assistance 2007	66	\$	28,512.00
<b>TOTAL</b>	<b>121</b>	<b>\$</b>	<b>109,644.00</b>



Community Contact provides necessary services for the less fortunate citizens in our communities, who would otherwise have to seek help from the town. We are depending upon funding from your town and neighboring communities countywide. The local funds are combined with the Community Services Block Grant, Fuel Assistance and NH Emergency Shelter Grant, Homeless Program and FEMA. We also are the conduit through which the USDA Surplus food gets distributed to food pantries, including our own, throughout Coos County in order to serve our residents.

If you have any questions, please don't hesitate to give me a call at 788-4477.

Sincerely,

Amy Zanes  
Lancaster Community Contact Manager



## North Country Council, Inc.

Regional Planning Commission & Economic Development District  
The Cottage at the Rocks  
107 Glessner Road  
Bethlehem, New Hampshire 03574  
(603) 444-6303 FAX: (603) 444-7588  
E-mail: [nccinc@nccouncil.org](mailto:nccinc@nccouncil.org)

Town of Whitefield  
7 Jefferson Road  
Whitefield, NH 03598

I would like to thank all of you for your support of the North Country Council (NCC) this past year. We have made a number of positive changes and completed a number of projects throughout the region. Once again, we reaffirmed the Council's commitment to serve community and regional needs.

During the past year, we have continued to deliver planning services throughout the region as you will see in the enclosed report. We have and will continue to adjust our capacities to respond to the needs of the communities, which will be evident in the programs being introduced in the coming years. Our strong relationship with the Department of Commerce and the Economic Development Administration (EDA) continues and has brought funding and project development into the region. The Sustainable Economic Initiative and the Coos Economic Adjustment Strategy continue to be major programs funded by EDA. Our Community Outreach program, targeted at helping our planning boards in the difficult tasks of managing the planning activities in their communities, is ongoing. NCC has been awarded an additional grant from EPA for Brownfields assessments and will be looking for sites and communities where these assessments can be utilized. These programs as well as all the traditional programs in master planning, solid waste management, grant writing, natural resource planning, hazardous mitigation planning and transportation planning will continue to be the focus of North Country Council. If you would like further information on any of these programs, please do not hesitate to call us.

Please take the time to look over this annual report and give us some feedback as to where you think the Council could improve and how we might better serve our communities.

Again, thank you for all of your support of the Council. The Council is here to serve you and to be of service to your community. It is your organization. Our staff and Board are committed to responding to community need. If there is a project or a need in your town, please call us. We are dedicated to both supporting our individual towns and promoting regional unity in the North Country.

Respectfully submitted,

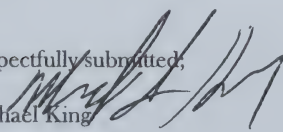
  
Michael King  
Executive Director



WEEKS MEDICAL CENTER  
▲ DARTMOUTH-HITCHCOCK

**Home Health & Hospice  
Services**

**Annual Report – 2007  
Town of Whitefield**

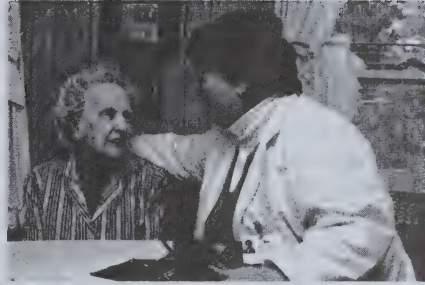

Beverlee Richter, Home Health and Hospice Nurse, shares a tender moment with a hospice patient.

Weeks Medical Center-Home Health and Hospice is grateful for the opportunity to serve the residents of Whitefield and greatly appreciates your continued support and confidence. Town funding is critically important and is used to assist families and individuals who are unable to pay for Home Health and Hospice Services and to support care where funding does not cover direct costs.

Our Home Health and Hospice Services continue to provide Whitefield residents with a wide range of services. Weeks Home Health and Hospice provides continuity of health care from the hospital to patients' homes. Services include skilled nursing; physical, occupational and speech therapies; licensed home health aides; homemakers; medical social services; intravenous therapies and care to the terminally ill.

Our Medicare Certified Hospice program continues to provide excellent palliative care to the terminally ill. Weeks Hospice is a special kind of holistic care . . . focusing on the emotional and spiritual needs of the family, as well as the physical needs of the patient at the end of life. No one is refused care based on an inability to pay. Over the last year, an increasing number of hospice patients received care, support and love from our nurses, aides and volunteers. To celebrate their memory, a luminary service was held and many residents from area towns were in attendance.

**Thank you for your continuing support and confidence.**

## White Mountain Mental Health and Common Ground Director's Report

### Town of Whitefield

As you sit on those folding chairs or bleachers at town meeting and listen to the warrant articles being discussed, you may wonder how the money you appropriate to White Mountain Mental Health/Common Ground is used in your town. This report is one means of informing you, the taxpayer, about what is done with this funding.

First, in general terms: the impact of your support is seen in children who become more successful in school and better prepared for adulthood, in adults who resume functioning as employees and parents, in elders who are able to stay independent and productive and in families with a developmentally disabled member who are able to move forward with their own lives, knowing that there is support outside of the family circle for their loved one. People who receive life-saving medical services are eager to tell their friends and family about the success of their care. You have seen "cards of thanks" in the local papers, naming the physicians, nurses, family and friends who came to the aid of a grateful patient. These thanks are well deserved! But...have you ever seen a similar tribute to mental health, substance abuse or developmental disability professionals who saved a life by being available to intervene in a life-threatening crisis of a different type? Chances are that your family member or neighbor will not advertise the fact that they have needed and used our services; life's challenges are often kept private. Having diabetes is much more acceptable than having schizophrenia, although both are chronic illnesses that can be managed through treatment, lifestyle education and support. We still struggle with the stigma attached to both behavioral health and developmental disability, but who among us has not been impacted by one or both?

Support for our services is an investment in the health and productivity of your town. In the North Country, unlike many parts of the State and Country, services continue to be available to ALL residents, not just those who can pay or those with a severe, biologic mental illness. This is because our towns and other supporters have recognized that unaddressed mental health and developmental issues have a tremendous negative "ripple effect" on the family, the economy and the whole community.

Although it is impossible to list all that we do, our core services include:

- 24 hour crisis intervention and assessment service for mental health emergencies
- Individual, marriage and family counseling, offered by highly trained mental health professionals with a variety of specialties
- Medication consultations to local physicians by Board certified psychiatrists
- "Full-life" supports for persons with serious and persistent mental illness, including housing, vocational and case management services
- Individualized home placements for more than fifty persons with developmental disabilities
- Life-enriching jobs and social connections for people with mental illness and developmental disabilities
- Substance abuse prevention and treatment by our staff of licensed alcohol and drug abuse counselors

**Service Statistics Highlights:**

- **In 2007, 83 residents of the town of Whitefield received 584 hours of outpatient mental health or substance abuse treatment services at a discounted rate. Our ability to continue to offer these services on a sliding-fee scale is dependent upon the support of our communities.**
- **100 families in our area received extensive assistance in supporting a person with a developmental disability. In many cases, the supports include “full-life” around the clock services.**

**Thank you for your continued support.**

**Respectfully submitted,**

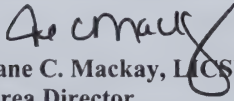

**Jane C. Mackay, LICSW  
Area Director**

**Caleb Interfaith Volunteer Caregivers**  
**38 King's Square, Suite 9**  
**Whitefield, NH 03598**

The Caleb Interfaith Volunteer Caregivers, a not-for-profit organization, which was established in October of 1995, continues to provide services to older adults in 8 northern New Hampshire communities. Caleb's heartfelt mission is to enhance independent living for the elderly, infirm and homebound by relieving isolation and assisting with friendly visits, care and supportive services through a network of volunteers and the fostering of caring communities.

In 2007, Caleb Caregivers assisted 296 Bethlehem, Dalton, Groveton, Jefferson, Lancaster, Littleton, Twin Mountain and Whitefield seniors. Over \$50,724.05 worth of services were provided **FREE** to our clients. Caleb's 88 active volunteers donated over 2,703 hours and drove over 26,182 miles to help their older neighbors remain independent! Without these dedicated volunteers, Caleb would not exist. These volunteers give their time, their talents and most of all their hearts. Transportation to medical appointments, and for running errands, is one of the most requested services through Caleb. Caleb Volunteers made 803 trips this year. Of these trips 82 were long distance, taking seniors to Dartmouth Hitchcock Medical Center, North Conway, Manchester, Concord, White River Junction, and St. Johnsbury, to name a few. It costs \$2.00 per mile to take a ride in a local taxicab, and Caleb's rides are provided **free of charge**.

Transportation is only **one** of the services that Caleb volunteers provide. Caleb volunteers provide other services as well; friendly visiting, telephone reassurance, help with chores, paperwork and light housekeeping are to name a few. Caleb volunteers also assist with various community programs, such as the Commodity Supplemental Food Program. This State program is available, every other month, to New Hampshire seniors that are 60+, and that financially qualify. Caleb volunteers help distribute this food to seniors, who are totally homebound. Caleb continues to work with various pet organizations, regarding Caleb's Pet Food Project. Since this project began, in October of 2002, Caleb has given out over **20** tons of **FREE** pet food/litter to help seniors feed their pets! Not only has Caleb assisted various community programs, Caleb has also partnered with various organizations such as AARP, FIA (Faith In Action) and Service Link. These partnerships enable Caleb to better serve its Seniors. Last but not least, Caleb still provides training for seniors who want to learn how to use computers. Without the various services that Caleb provides, many older adults who need just a little extra help to continue living independently, might have had to go into a nursing home. The average cost of nursing home care is \$185.00 per day.

There are no fees for the services that are provided by the Caleb Caregivers. The program is funded through grants, fundraisers, donations and generous appropriations of the towns in which the services are provided. We

want to thank the residents of Whitefield for their support and for making it possible for us to continue to provide these much needed services to the area's elders. The \$3,300.00 appropriated at last year's Town Meeting was greatly appreciated, and we ask for your continued support in 2008.

Volunteers are always in great demand, so if you would like to become a volunteer, request a volunteer, or know someone who would benefit from our services, please call the Caleb Office at 837-9179, or contact anyone on the Board of Directors.

Neighbors helping neighbors, is what Caleb is all about, and it is what North Country residents are all about, too!

Respectfully submitted,  
BOBBIE GAUDES  
Executive Director

**Board of Directors**

- Carl Rod, President-Jefferson
- Larry Berg, Vice-President- Whitefield
- David Glover, Treasurer-Whitefield
- Myra Emerson, Clerk-Lancaster
- Marie Dubreuil-Jefferson
- Rev. Virginia Alvarez-Lancaster



# North Country Elder Programs

Senior Meals/Senior Centers ~ Alzheimer's Health Care Services ~ ServiceLink  
Tri-County Community Action Program, Inc.

January 10, 2008

Whitefield Board of Selectmen  
Town Hall Offices  
7 Jefferson Road  
Whitefield, NH 03598

Dear Board of Selectmen:

On behalf of North Country Elder Programs, I would like to respectfully request funding in the amount of \$2,800.00 for the Senior Meals Program to be included in the upcoming Town of Whitefield budget process.

During the time period of July 1, 2006 to June 30, 2007 (Fiscal Year 2007) we served Whitefield residents 766 congregate meals and 14,738 home delivered meals, an increase of 27.1% over last years figures. The Senior Meals Program in Fiscal Year 2007 was able to prepare and serve 143,549 meals county-wide to senior citizens in need of nutritional assistance.

The current need in Whitefield is evident and is likely to continue on the same trend as the population continues to age and require nutritional assistance offered through the Senior Meals Program. The many benefits received by the residents of Whitefield is one of socialization and personal growth as participants at the congregate site receive not only a hot, nutritious meal, but opportunities to interact with their peers through volunteering, social activities and one on one contact. On the other hand, homebound individuals receive nutritious meals delivered directly to their homes by the Meals on Wheels delivery team, and oftentimes, it is the participants only contact with the community. It is, therefore, vital that the needs of this frail population be met with support from their local friends and neighbors.

The Town of Whitefield's past support for this community-based program has been greatly appreciated and we welcome your questions and comments pertaining to this request for funding. Please call our administrative offices at 752-3010, Monday through Friday, and we'd be glad to speak with you.

Thank you for your consideration of this request.

Respectfully,

Patricia Stolte, Director  
North Country Elder Programs





# Tri-County CAP, Inc. North Country Transit

*Public Transit to the North Country  
Senior Wheels-Public Transit-Long Distance Medical*

31 Pleasant Street, Suite 100 , Berlin NH 03570

Phone: 603-752-1741 Fax: 603-752-2117

**Toll Free: 1 -888-997-2020**

Serving the areas of Berlin/Gorham Pittsburg/Colebrook/N. Stratford Groveton/Whitefield Lancaster/Littleton

December 7, 2007

Whitefield Board of Selectmen  
Town of Whitefield  
7 Jefferson Rd  
Whitefield NH 03585

Dear Board of Selectmen;

On behalf of Tri-County CAP, Inc., North Country Transit, (Senior Wheels Program) I would like to respectfully request funding in the amount of \$1800.00 to Support The Senior Wheels Demand Response Program and the amount of \$1700.00 to support the Lancaster-Whitefield-Littleton Tri Town Public Transit Route to be included in the upcoming Town of Whitefield Budget.

The Senior Wheels Program provides a demand response transportation service to area residents 60+ requesting rides to medical appointments, hairdressers, grocery shopping, social events, senior meals, and employment. Residents utilizing this service are afforded an opportunity to be mobile and independent thus increasing their sense of worth and value which in turn contributes to the community as a whole. Last year NCT provided 3118 trips for this service. The Tri Town Public Transit Route provided 7744 trips to people of all ages the opportunity of obtaining affordable transportation to job access, shopping, medical appointments, and attendance at daily social events within the Tri Town areas.

Your past support of this community-based program has been greatly appreciated and we welcome your questions and comments pertaining to this request for funding. Please call the administrative offices at 752-1741, Monday through Friday, and we'd be glad to speak with you.

Again, thank you for your consideration and past support.

Respectfully,

Beverly Raymond  
Director  
North Country Transit

ANNUAL REPORT  
NORTH COUNTRY HOME HEALTH AND HOSPICE AGENCY, INC.  
TOWN OF WHITEFIELD  
2007

North Country Home Health & Hospice Agency has been meeting the home health and hospice needs of the North Country since 1971.

North Country Home Health & Hospice Agency provides skilled services such as nurses, therapist, home health aides, medical social workers, and homemakers. Under our hospice program we also pay for medications for symptom relief, medical supplies and equipment, short term hospitalization and in-patient respite care, counseling and pastoral support. Our Compassionate Care program provides limited amounts of free skilled care to those living with a life-limiting illness who are not eligible for traditional hospice benefits. In January 2007, we added hospice volunteer services to improve our continuum of care by creating an even stronger program of hospice and palliative care for residents. In 2007, we traveled 230,447 miles to provide 25,781 visits to the residents in our 21-Town service area.

North Country Home Health and Hospice relies on Town support and individual donations to help underwrite the cost of providing home health and hospice care to residents who are uninsured or underinsured. The Board of Directors and Staff of North Country Home Health & Hospice are grateful for your continued support of our work in this community and look forward to working with you to meet the home care and hospice needs of the residents of Whitefield.

<u>Type of Care</u>	<u># of Visits</u>
Nursing	343
Physical/Occupational /Speech Therapy	161
Medical Social Service	44
Home Health Aide/Homemaker	1,486
Hospice Volunteer Coordinator	<u>14</u>
Total	2,049

Miles Driven 12,525 Miles

Hospice Volunteer Support

# of Patients	4
# of Hours	246

Respectfully Submitted,

*Gail Tomlinson*

Gail Tomlinson  
Executive Director



# AMMONOOSUC COMMUNITY HEALTH SERVICES, INC.

November 12, 2007  
Board of Selectmen  
Town of Whitefield  
7 Jefferson Road  
Whitefield, NH 03598

Dear Selectmen,

Ammonoosuc Community Health Services Inc. (ACHS) is requesting an appropriation in the amount of \$2,500 from the Town of Whitefield for 2008. This represents a per capita amount of \$1.20 for each town resident and will help us continue to provide high quality care to our **955 current Whitefield patients**, as well as reach more of those who need our services.

Although ACHS has been in existence since 1975, this is our fourth request for town support. While many of our services are paid for through Medicare, Medicaid and grants, we have seen our patient population increase 41% over the last 2 years due to economic conditions and the increase in the uninsured population. Unfortunately, our reimbursements through these federal, state and county programs fall short of actual expenses.

ACHS serves 26 towns in northern Grafton and southern Coos counties and has sites located in Littleton, Franconia, Whitefield, Warren and Woodsville. As a Federally Qualified Health Center, ACHS receives federal funding to provide comprehensive preventive and primary health care to anyone, *regardless of their insurance status or ability to pay*. Clinical teams, made up of doctors, nurse practitioners or physician assistants supported by nurses and medical assistants, provide comprehensive services on a sliding fee scale to over 6,500 patients. ACHS provided the following services in calendar year 2007:

• **Comprehensive Primary Care services to 7,298 medical users**

- On-site Perinatal services to 148 women
- Family Planning services to 1084 users
- HIV Counseling and Testing services to 175 clients
- CSFP food distribution to 455 individuals per month (mostly elderly)
- Toddler care seat loan/donation program to 50 families
- Oral Health services to 114 adults
- Well Child Health services to 629 children
- Cancer Screening services to 1000 high risk women
- WIC services to 755 individuals per month
- Health Education services through 197 presentations to schools and community groups
- Family Support services to 147 families
- Depression care to 558 individuals

In addition, ACHS's 340 B sliding fee drug and patient assistance programs provided more than **\$1.5 million dollars in free and reduced cost drugs** to our patients in less than two years. *Our Medical Staff also cares for the residents of Morrison Nursing Home in Whitefield.*

We would be happy to meet with you to answer any questions that you may have. On behalf of Ammonoosuc Community Health Services' board of directors, staff and patients we would like to thank you for consideration of this financial request.

Sincerely,

  
Norrine Williams  
Executive Director

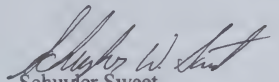
  
Schuyler Sweet  
President, Board of Directors

MAIN OFFICE

25 Mt. Eustis Road  
Littleton, NH 03561  
(603) 444-2464  
Fax (603) 444-5209

79 Swiftwater Road  
Woodsville, NH 03785  
(603) 747-3740  
Fax (603) 747-0416

14 Kings Square  
Whitefield, NH 03598  
(603) 837-2333  
Fax (603) 837-9790

155 Main Street  
Franconia, NH 03580  
(603) 823-7078  
Fax (603) 823-5460

333 NH Rte 25  
Warren, NH 03279  
(603) 764-5704  
Fax (603) 764-5705



600 St. Johnsbury Road, Littleton, NH 03561

Phone: 603-444-9000 or 800-464-7731

Fax: 603-444-0443

www.littletonhospital.org

December 6, 2007

Town of Whitefield  
Town Hall  
Whitefield, NH 03598

Dear Selectmen:

Littleton Regional Hospital is pleased to report that it has achieved considerable improvement in its operational and financial vitality this last fiscal year and has maintained it's financial support to the Towns we serve.

During the period of July 1, 2006-June 30, 2007 Littleton Regional Hospital provided a record \$4,485,214.00 in community benefits to our patients, their families, community health organizations and Towns in our service area. During this period Littleton Regional Hospital provided \$1,134,127.00 in charitable care alone.

Littleton Regional Hospital stands ready to care for all patients from the Town of Whitefield, regardless of their ability to pay for, often lifesaving medical care. In fiscal year 2007, Littleton Regional Hospital provided \$118,097.00 in charity care to patients residing in Whitefield.

The amount of financial support Littleton Regional Hospital receives from Towns represents only a fraction of the costs of providing charity care and community support programs to the Communities we serve. The Littleton Regional Hospital management and staff who strive to provide the best care and service to all our patients sincerely appreciate your Community's continued support and commitment to Littleton Regional Hospital.

This year Littleton Regional Hospital requests a financial donation in the amount of \$2,000.00 from the Town of Whitefield which includes a modest 5% increase over the previous years request, to help offset the cost of community benefit programs that the Hospital provides free to the Communities we serve including our free Paramedic Intercept program and our free "Care-A-Van" patient transport services to the residents in your community.

On behalf of our entire Littleton Regional Hospital Family (Board, Medical Staff, Hospital Staff, Volunteers and Auxiliary) we thank you and your Community for your ongoing support and consideration of this financial request. As always it is an honor to serve the residents of Whitefield. If you have any questions please feel free to contact Kurt Lucas, Director Community Health Access at 444-9205 or at [klucas@littletonhospital.org](mailto:klucas@littletonhospital.org).

Sincerely,

A handwritten signature in black ink, appearing to read "Edward L. Duffy".

Edward L. Duffy, MD  
Chairman, Board of Trustees

A handwritten signature in black ink, appearing to read "Warren K. West".

Warren K. West, CHE  
C.E.O.

Cc: Kurt Lucas, Director, Community Health Access



MASON + RICH

PROFESSIONAL ASSOCIATION  
Certified Public Accountants

## REPORT OF INDEPENDENT AUDITORS

To the Board of Selectmen

We have audited the accompanying financial statements of the governmental activities, the business-type activities, each major fund, and the aggregate remaining fund information of the Town of Whitefield, New Hampshire, as of and for the year ended December 31, 2006, which collectively comprise the Town of Whitefield's basic financial statements as listed in the index. These financial statements are the responsibility of the Town of Whitefield's management. Our responsibility is to express opinions on these financial statements based on our audit.

We conducted our audit in accordance with auditing standards generally accepted in the United States of America and the standards applicable to financial audits contained in *Government Auditing Standards*, issued by the Comptroller General of the United States. Those standards require that we plan and perform the audit to obtain reasonable assurance about whether the financial statements are free of material misstatement. An audit includes examining on a test basis, evidence supporting the amounts and disclosures in the financial statements. An audit also includes assessing the accounting principles used and significant estimates made by management, as well as evaluating the overall financial statement presentation. We believe that our audit provides a reasonable basis for our opinions.

In our opinion, the financial statements referred to above present fairly, in all material respects, the respective financial position of the governmental activities, the business-type activities, each major fund, and the aggregate remaining fund information of the Town of Whitefield, New Hampshire, as of December 31, 2006 and the respective changes in financial position and cash flows, where applicable, thereof, for the year then ended in conformity with accounting principles generally accepted in the United States of America.

In accordance with *Government Auditing Standards*, we have also issued our report dated February 10, 2008 on our consideration of the Town's internal control over financial reporting and on our tests of its compliance with certain provisions of laws, regulations, contracts, and grant agreements and other matters. The purpose of that report is to describe the scope of our testing of internal control over financial reporting and compliance and the results of that testing and not to provide an opinion on the internal control over financial reporting or on compliance. That report is an integral part of an audit performed in accordance with *Government Auditing Standards* and should be considered in conjunction with this report in considering the results of our audit.

SIX  
BICENTENNIAL  
SQUARE  
CONCORD NH  
03301  
T 603.224.2000  
F 603.224.2613

VISIT US AT [WWW.MASONRICH.COM](http://WWW.MASONRICH.COM)

The management's discussion and analysis and budgetary comparison information on pages 3 through 9 and 44 through 47 are not a required part of the basic financial statements but are supplemental information required by accounting principles generally accepted in the United States of America. We have applied certain limited procedures, which consisted principally of inquiries of management regarding the methods of measurement and presentation of the supplemental information. However, we did not audit the information and express no opinion on it.

Respectfully Submitted,

*Mason + Rich, P.A.*

MASON + RICH PROFESSIONAL ASSOCIATION  
Certified Public Accountants

February 10, 2008



MASON + RICH

**PROFESSIONAL ASSOCIATION**  
Certified Public Accountants

Board of Selectmen  
Town of Whitefield  
Whitefield, New Hampshire

In planning and performing our audit of the financial statements of the Town of Whitefield, New Hampshire for the year ended December 31, 2006 we considered the Town's internal control structure to determine our auditing procedures for the purpose of expressing an opinion on the financial statements and not to provide assurance on the internal control structure.

During the current year's audit we did become aware of one matter that provided an opportunity for strengthening internal controls and operating efficiency. The memorandum that accompanies this letter addresses our prior audit finding and recommendation. This letter does not affect our report dated February 10, 2008 on the financial statements of the Town of Whitefield, New Hampshire.

We will review the status of this comment during our next audit engagement. We have already discussed this comment and suggestion with Town personnel and we will be pleased to discuss them in further detail at your convenience, to perform any additional study of these matters or to assist you in implementing our recommendations

Respectfully submitted,

*Mason + Rich, P.A.*

MASON + RICH PROFESSIONAL ASSOCIATION  
Certified Public Accountants

February 10, 2008

SIX  
BICENTENNIAL  
SQUARE  
CONCORD NH  
03301  
T 603.224.2000  
F 603.224.2613

VISIT US AT [WWW.MASONRICH.COM](http://WWW.MASONRICH.COM)

TOWN OF WHITEFIELD, NEW HAMPSHIRE  
MANAGEMENT LETTER

---

**FINDINGS AND RECOMMENDATIONS:**

**CONTROLS OVER VENDOR DISBURSEMENTS**

**Finding** – The Town has established internal controls which dictate the need for two (2) Selectmen’s signatures along with the Treasurer’s on each check. Upon testing we noted that this is not done consistently. The internal controls also require the written approval of Department Heads to appear on each invoice as well as each time sheet prior to payment. Upon testing we noted that this is not done consistently.

**Recommendation** - Require Selectmen and Department Heads to follow internal control procedures prior to payment.

**Management’s Comment** – The Town is aware of this finding and will work with our auditor to find a solution.



TOWN OF WHITEFIELD, NEW HAMPSHIRE  
STATEMENT OF NET ASSETS  
DECEMBER 31, 2006

	Governmental Activities	Business- Type Activities	Total
<b>ASSETS</b>			
Cash and Equivalents	\$ 102,246	\$ 126,563	\$ 228,809
Temporary Investments	735,887	103,955	839,842
Investments	988,090	-	988,090
Taxes Receivable	441,551	-	441,551
Accounts Receivable	24,042	77,303	101,345
Due from Other Governments	21,823	21,255	43,078
Internal Balances	6,085	(6,085)	-
Inventory and Prepaids	-	-	-
Property by Tax Deed and Title	1,142	-	1,142
Capital Assets:			
Land and Improvements	350,388	29,063	379,451
Buildings and Improvements	504,695	-	504,695
Sewer System	-	2,416,221	2,416,221
Water System	-	2,134,001	2,134,001
Infrastructure	3,919,201	-	3,919,201
Furniture, Equipment and Vehicles	1,227,357	119,882	1,347,239
Construction in Progress	34,360	-	34,360
Less Accumulated Depreciation	(1,419,536)	(1,244,572)	(2,664,108)
Total Capital Assets, Net of Depreciation	4,616,465	3,454,595	8,071,060
<b>TOTAL ASSETS</b>	<b>\$ 6,937,331</b>	<b>\$ 3,777,586</b>	<b>\$ 10,714,917</b>

(Continued)

TOWN OF WHITEFIELD, NEW HAMPSHIRE  
STATEMENT OF NET ASSETS  
DECEMBER 31, 2006

	Governmental Activities	Business- Type Activities	Total
<b>LIABILITIES</b>			
Accounts Payable	\$ 80,834	\$ 1,925	\$ 82,759
Retainage Payable	24,000	-	24,000
Due to Other Governments	599,177	-	599,177
Accrued Liabilities	22,089	6,938	29,027
Deferred Revenues	7,683	7,709	15,392
Current Portion of Long-term Debt	47,707	36,950	84,657
Noncurrent Liabilities:			
Obligations Under Capital Leases	-	-	-
Bonds and Notes	514,535	546,097	1,060,632
Compensated Absences	2,803	-	2,803
Estimated Landfill Closure and Postclosure Monitoring Costs Payable	517,000	-	517,000
<b>Total Liabilities</b>	<u>1,815,828</u>	<u>599,619</u>	<u>2,415,447</u>
<b>NET ASSETS</b>			
Invested in Capital Assets, Net of Related Debt	4,054,223	2,871,548	6,925,771
Restricted for:			
Capital Reserves	365,627	-	365,627
Water Fund Capital Asset Repair and Replacement	22,108	-	22,108
Permanent Funds:			
Nonexpendable	103,922	-	103,922
Unrestricted	575,623	306,419	882,042
<b>Total Net Assets</b>	<u>\$ 5,121,503</u>	<u>\$ 3,177,967</u>	<u>\$ 8,299,470</u>

The Accompanying Notes are an Integral Part of This Financial Statement

- Page 11 -

TOWN OF WHITEFIELD, NEW HAMPSHIRE  
STATEMENT OF ACTIVITIES  
FOR THE YEAR ENDED DECEMBER 31, 2006

Functions/Programs	Program Revenues			Net (Expense) Revenue and Change in Net Assets			
	Expenses	Charges for Services	Operating Grants and Contributions	Capital Grants and Contributions	Governmental Activities	Business-type Activities	Total
<b>Governmental Activities:</b>							
General Government	\$ 673,853	\$ 358,985	\$ 200	\$ 11,800	\$ (302,868)	\$ -	\$ (302,868)
Police Department	263,490	23,098	3,050	-	(237,342)	-	(237,342)
Fire Department	214,878	119,429	-	-	(95,449)	-	(95,449)
Airport	81,659	-	-	445,524	363,865	-	363,865
Highways and Streets	443,804	3,068	61,594	715,000	335,858	-	335,858
Sanitation Operations	(153,695)	62,685	-	-	216,380	-	216,380
Health and Welfare	44,897	-	-	-	(44,081)	-	(44,081)
Parks and Recreation	60,772	260	8,073	-	(52,439)	-	(52,439)
Cultural	31,450	223	1,262	-	(29,965)	-	(29,965)
Conservation	1,586	-	-	-	(1,586)	-	(1,586)
Economic Development	4,102	-	-	-	(4,102)	-	(4,102)
<b>Intergovernmental:</b>							
School District	2,021,177	-	-	-	(2,021,177)	-	(2,021,177)
County	608,141	-	-	-	(608,141)	-	(608,141)
Interest on Long-term Debt	26,048	-	-	-	(26,048)	-	(26,048)
<b>Total Governmental Activities</b>	<b>4,322,162</b>	<b>568,564</b>	<b>74,179</b>	<b>1,172,324</b>	<b>(2,507,095)</b>	<b>-</b>	<b>(2,507,095)</b>
<b>Business-type Activities</b>							
Water	145,049	112,940	6,773	-	-	(25,336)	(25,336)
Sewer	211,756	153,678	4,283	-	-	(53,795)	(53,795)
<b>Total Business-type Activities</b>	<b>356,805</b>	<b>266,618</b>	<b>11,056</b>	<b>-</b>	<b>-</b>	<b>(79,131)</b>	<b>(79,131)</b>
<b>Total</b>	<b>\$ 4,678,967</b>	<b>\$ 835,182</b>	<b>\$ 85,235</b>	<b>\$ 1,172,324</b>	<b>(2,507,095)</b>	<b>(79,131)</b>	<b>(2,586,226)</b>

General Revenues:	
Taxes:	
Property Taxes:	
Levied for General Purposes	800,897
Levied for Education	2,021,177
Levied for the County	608,141
Franchise Fees	-
Payment in Lieu of Taxes	-
Other Taxes	42,642
Grants and Contributions Not Restricted to Specific Programs	115,879
Interest and Investment Earnings	118,927
Gain (Loss) on Sale of Capital Assets	64,983
Miscellaneous	(8,495)
Transfers	35,032
Total General Revenues, Special Items and Transfers	(78,088)
Change in Net Assets	3,721,095
Net Assets, Beginning of Year	1,214,000
Net Assets, End of Year	3,907,503
Net Assets, End of Year	\$ 5,121,503
Net Assets, End of Year	\$ 3,177,967
Net Assets, End of Year	\$ 8,299,470

The Accompanying Notes are an Integral Part of This Financial Statement

TOWN OF WHITEFIELD, NEW HAMPSHIRE  
BALANCE SHEET  
GOVERNMENTAL FUNDS  
DECEMBER 31, 2006

	Major Funds			Total Governmental Funds
	General Fund	Capital Reserves	Other Governmental Funds	
<b>ASSETS</b>				
Cash and Cash Equivalents	\$ 56,438	\$ -	\$ 45,808	\$ 102,246
Temporary Investments	18,552	365,627	351,708	735,887
Investments	987,426	-	663	988,089
Taxes Receivable	441,551	-	-	441,551
Accounts Receivable	24,042	-	-	24,042
Due from Other Governments	-	-	21,823	21,823
Due from Other Funds	22,316	-	27,676	49,992
Prepaids	-	-	-	-
Restricted Assets	-	-	-	-
Property by Tax Lien and Title	-	-	-	-
	12,640	-	-	12,640
<b>TOTAL ASSETS</b>	<b>\$ 1,562,965</b>	<b>\$ 365,627</b>	<b>\$ 447,678</b>	<b>\$ 2,376,270</b>

(Continued)

The Accompanying Notes are an Integral Part of This Financial Statement

TOWN OF WHITEFIELD, NEW HAMPSHIRE  
BALANCE SHEET  
GOVERNMENTAL FUNDS  
DECEMBER 31, 2006

	Major Funds			Total Governmental Funds
	General	Capital Reserves	Other Governmental Funds	
<b>LIABILITIES</b>				
Accounts Payable	\$ 60,911	\$ -	\$ 19,923	\$ 80,834
Contracts Payable	-	-	-	-
Retainage Payable	-	-	24,000	24,000
Due to Other Governments	599,177	-	-	599,177
Accrued Liabilities	10,766	-	-	10,766
Deferred Revenues	19,705	-	-	19,705
Due to Other Funds	35,349	-	8,558	43,907
<b>TOTAL LIABILITIES</b>	<u>725,908</u>	<u>-</u>	<u>52,481</u>	<u>778,389</u>
<b>FUND BALANCES</b>				
Reserved for Encumbrances	54,881	-	-	54,881
Reserved for Prepaids	-	-	-	-
Reserved for Permanent Funds Principal	-	-	-	-
Unreserved Reported in:				
General Fund	782,176	-	-	782,176
Special Revenue Funds	-	365,627	233,025	598,652
Capital Projects Funds	-	-	(3,922)	(3,922)
Undistributed Net Revenues of Permanent Funds	-	-	62,172	62,172
<b>TOTAL FUND BALANCES</b>	<u>837,057</u>	<u>365,627</u>	<u>395,197</u>	<u>1,597,881</u>
<b>TOTAL LIABILITIES AND FUND BALANCES</b>	<u>\$ 1,562,965</u>	<u>\$ 365,627</u>	<u>\$ 447,678</u>	<u>\$ 2,376,270</u>

The Accompanying Notes are an Integral Part of This Financial Statement

TOWN OF WHITEFIELD, NEW HAMPSHIRE  
RECONCILIATION OF TOTAL GOVERNMENTAL FUND BALANCE  
TO NET ASSETS OF GOVERNMENTAL ACTIVITIES  
DECEMBER 31, 2006

*Total Governmental Fund Balances* \$ 1,597,881

*Amounts Reported for Governmental Activities in the Statement of Net Assets Are Different Because of the Following Items:*

Capital Assets Used in Governmental Activities Are NOT Financial Resources and Therefore Are NOT Reported in the Funds.

4,616,465

Other Long-term Assets, such as Elderly and Welfare Liens, Are NOT Available to Pay for Current-Period Expenditures and Therefore Are Deferred in the Funds.

522

Long-term Liabilities, Including Bonds Payable and Unmatured Compensated Absences, Are NOT Due and Payable in the Current Period and Therefore Are NOT Reported in the Funds.

(1,093,365)

*Net Assets of Governmental Activities - Statement 1*

\$ 5,121,503

The Accompanying Notes are an Integral Part of This Financial Statement



New Hampshire State Library



3 4677 00105364 9