

2-26-2013

270742 - B - Attachment A - Stanchion Assembly Detail

Sandra Hickey
sandra.hickey@unh.edu

Follow this and additional works at: https://scholars.unh.edu/pdch_5_27

Recommended Citation

Hickey, Sandra, "270742 - B - Attachment A - Stanchion Assembly Detail" (2013). *Division 27 – Communication*. 4.
https://scholars.unh.edu/pdch_5_27/4

This Article is brought to you for free and open access by the Chapter 5 – Technical Construction and Renovation Standards at University of New Hampshire Scholars' Repository. It has been accepted for inclusion in Division 27 – Communication by an authorized administrator of University of New Hampshire Scholars' Repository. For more information, please contact nicole.hentz@unh.edu.



GAI-TRONICS® CORPORATION
A HUBBELL COMPANY

Model 234 Stanchion Assembly and Model 234SBA Stanchion Broadcast Assembly

Confidentiality Notice

This manual is provided solely as an installation, operation, and maintenance guide and contains sensitive business and technical information that is confidential and proprietary to GAI-Tronics. GAI-Tronics retains all intellectual property and other rights in or to the information contained herein, and such information may only be used in connection with the operation of your GAI-Tronics product or system. This manual may not be disclosed in any form, in whole or in part, directly or indirectly, to any third party.

General Information

The Model 234 Stanchion Assembly is part of a completely integrated emergency communications station. The Model 234SBA Stanchion Broadcast Assembly helps to insure public safety by combining two-way communications with one-way public address broadcasting.

Both Model 234 Stanchion Assembly and Model 234SBA Stanchion Broadcast Assembly are designed to house a flush-mount telephone and a Model 530-001 or 531A strobe. Both stanchion assemblies are over 9 feet tall, making it easily located by potential users.

The strobe creates added visibility to emergency telephone locations by providing a constant-on lamp that automatically flashes when the emergency button is pressed. The telephone is also highly visible; a light mounted in the stanchion shines on the front of the telephone to illuminate the phone for nighttime use.

GAI-Tronics enhanced emergency telephones are designed for isolated high-risk areas requiring emergency communications equipment. Emergency telephone users simply press the clearly labeled emergency push button for immediate connection to a user-programmed central security telephone number.

The Model 234SBA Stanchion Broadcast Assembly combines two-way emergency communications with one-way public address broadcasting. Each Model 234SBA is capable of being equipped with up to four public address speakers.

The complete emergency stanchion, with or without public address, is shipped in two stages. The Model 84504-201 Hardware Kit is usually shipped in advance followed by the remaining assemblies (Model 84501-201, Model 84502-201 and Model 84503-201 or Model 84509-201 and related kits). Both the Model 234 and Model 234SBA use the same hardware kit.

Mounting

A concrete pier is required to support both of the stanchion assemblies. GAI-Tronics provides the Model 84504-201 Hardware Kit to aid with the construction of this pier.

We recommend using 3,000 psi grade concrete as a minimum. The pier must be strong enough to support a structure that is 9-1/2 feet tall and weighs 250 lbs.

Reinforcement Cage

We recommend that the concrete base be 3 feet deep and 18 inches wide, and that a reinforcement cage be used. The reinforcement cage is not provided by GAI-Tronics. The following materials are necessary to construct the reinforcement cage:

- four #4 rebars;
- three #4 ties;
- one 18-inch sonotube.

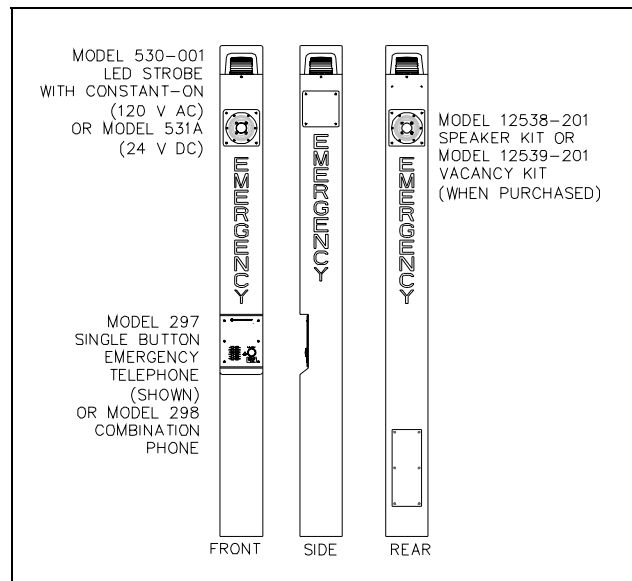

Figure 1. Model 234SBA shown

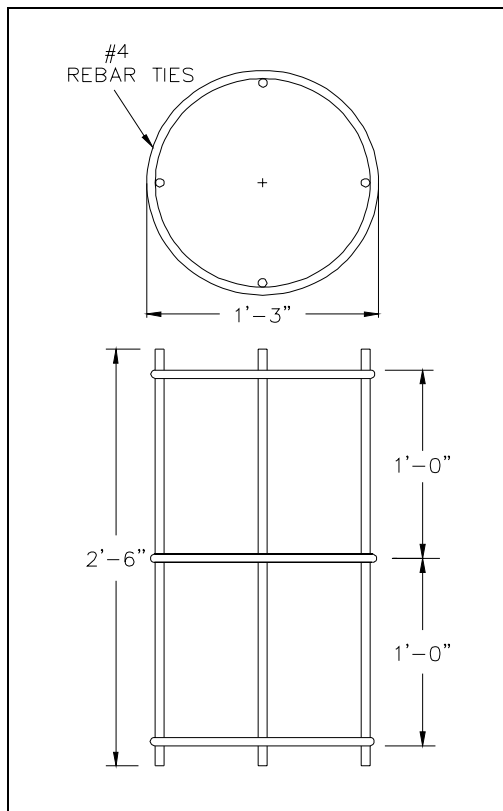

Figure 2. Reinforcement Cage

1. Construct the reinforcement cage by placing a horizontal member in the center of the rebar.
2. Place the two remaining horizontal members 12 inches from that center point. See Figure 2. The top of the cage should be 3 inches below the top of the pier.
3. The reinforcement cage in Figure 2 shows the maximum diameter that is suitable for a customer-provided 18-inch sonotube.
4. Install two conduits in the pier—one for the telephone wire and one for the electrical power wire.

NOTE: These conduits **MUST** be kept separate to prevent interference from occurring on the audio lines. Conduits are not supplied by GAI-Tronics.

Installation

⚠ ATTENTION ⚠ Installation should be performed by qualified personnel and only in accordance with the National Electrical Code and applicable local codes.

The following information provides guidelines on the installation of various components of the emergency station. Grounding electrode conductor (not depicted in the illustration) must be constructed in accordance with the National Electrical Code and applicable local codes.

Model 84504-201 Hardware Kit Installation

The Model 84504-201 Hardware Kit includes four anchor bolts, which should be installed so that they extend 3 inches above the top of the pier surface. See Figure 3.

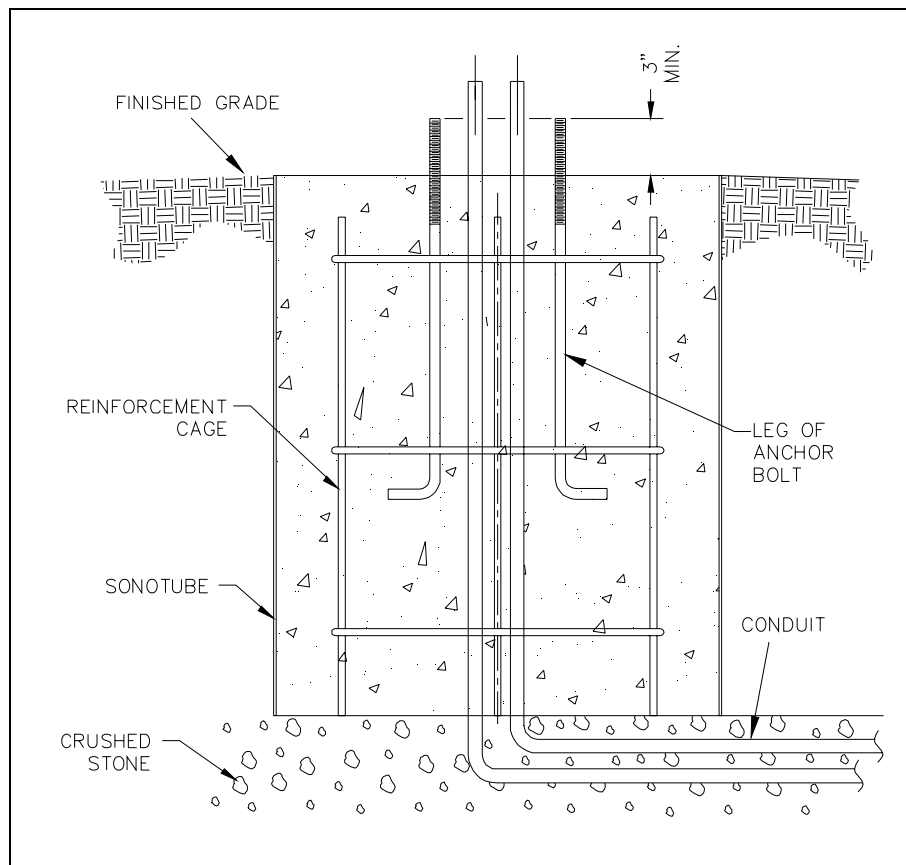

Figure 3. Front View

Use the template provided in the hardware kit for anchor bolt positioning, or see Figure 4 for dimensions. The 3-inch leg of the anchor bolts should point to the outside of the tube. Center lines should be measured across the corners.

NOTE: The stanchion should not be mounted until the concrete has been allowed to cure for a minimum of 24 hours.

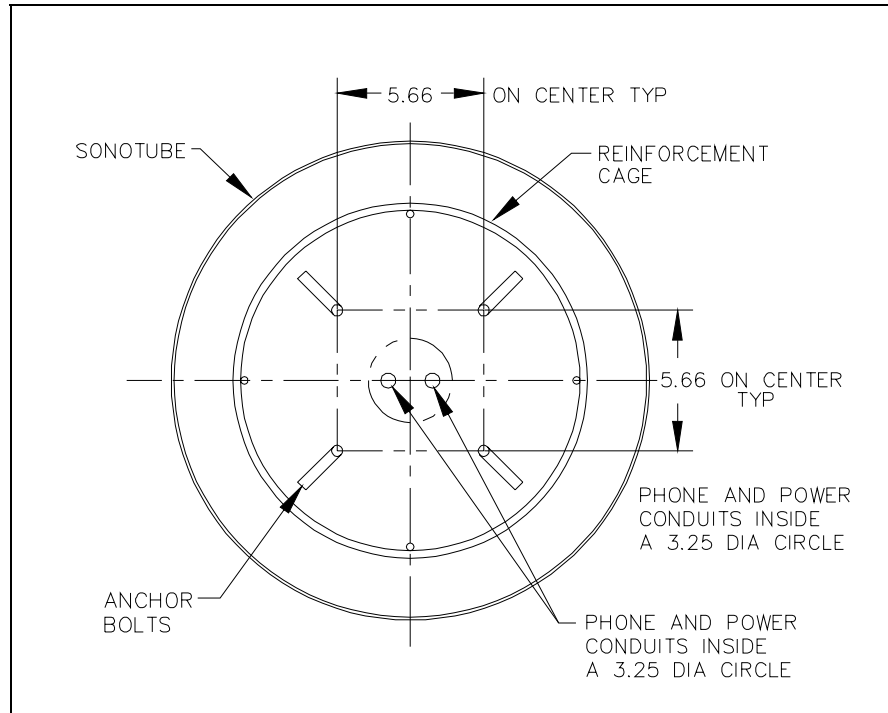

Figure 4. Top View

Model 84501-201 and 84509-201 Stanchion Main Body Installation

1. If the concrete is not level, find the anchor rod at the highest point of the concrete, and screw one $\frac{3}{4}$ -inch heavy hex nut $1\text{-}\frac{1}{8}$ inches above the concrete surface (measuring to the top of the nut).
See Figure 5.
2. Adjust the remaining three hex nuts to be level with the first. Place one washer over each heavy hex nut. See Figure 5 and Figure 6.

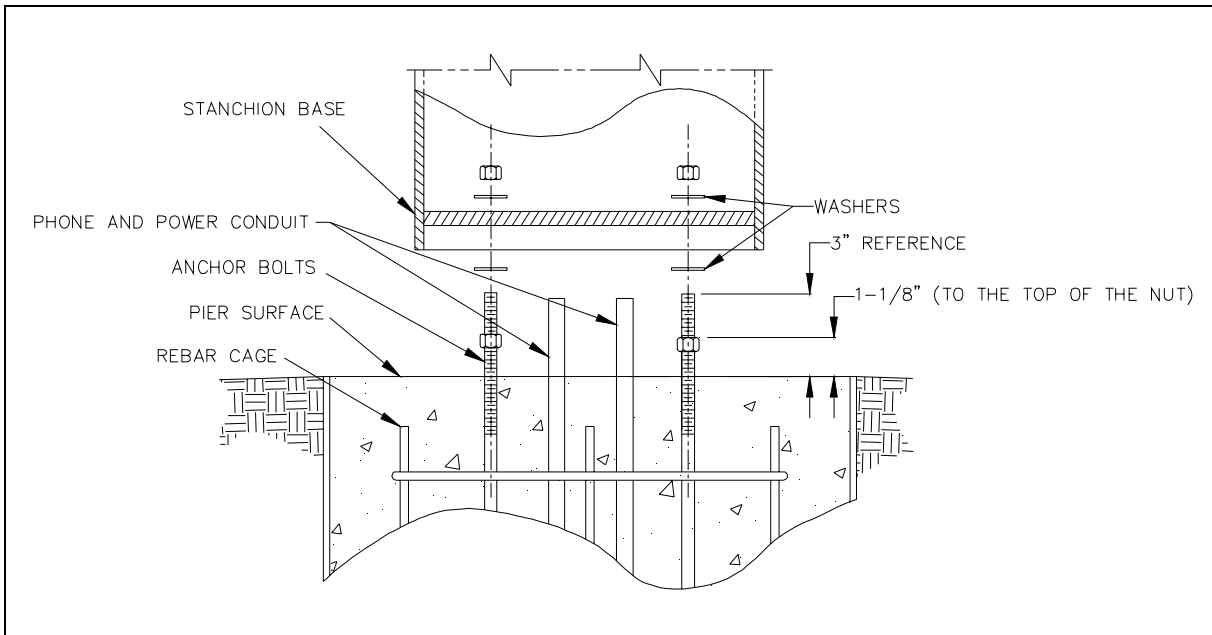

Figure 5. Exploded View

3. Before mounting the stanchion, unscrew the four tamper-resistant screws on the rear access panel, and remove the panel.
4. Apply a small amount of clear RTV silicone sealant or equivalent to each screw thread to reduce the possibility of rust forming in the screw threads.
NOTE: GAI-Tronics Model 233-001 Tamper-Resistant Screwdriver is required to remove tamper-resistant screws.
5. Place the stanchion on top of the four level, heavy hex nuts.
6. Entering through the rear access panel hole, place the four remaining washers on the anchor bolts, and secure with the $\frac{3}{4}$ -inch hex nuts. Do not install the access panel cover until the wiring is complete.

NOTE: A 1/4-inch air gap must exist between the base of the stanchion and the top of the concrete pier. See Figure 6. This air gap must not be obstructed with soil, mulch, stone, etc.

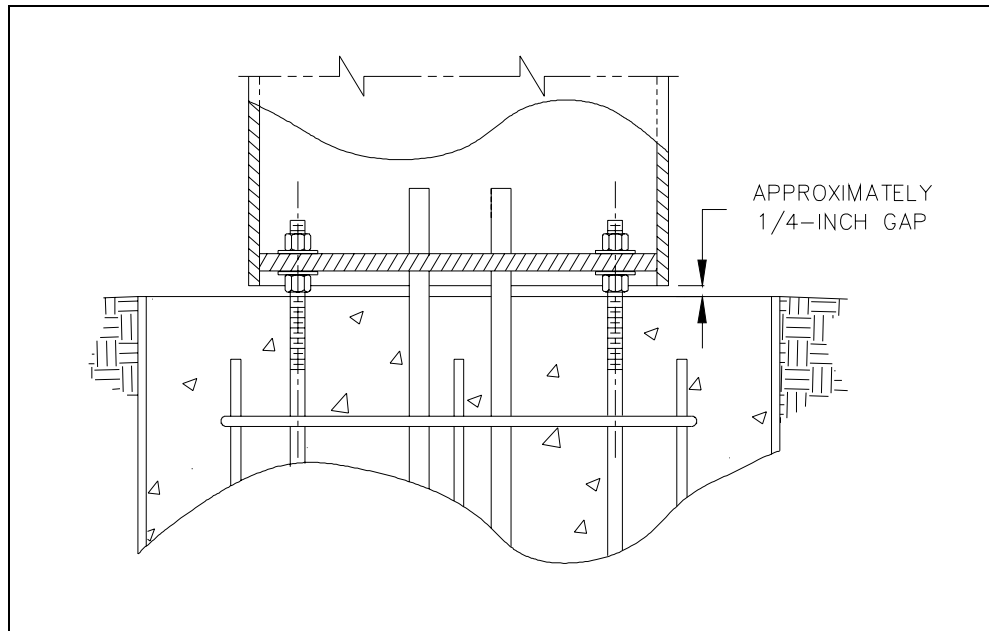

Figure 6. Assembled View

The unit should be installed and grounded in accordance with national and local electrical codes.

NOTE: A grounding stud connection has been provided inside the rear access panel.

Model 84503-201 Stanchion Panel Light Installation

1. Remove the two screws securing the bezel and lens to the stanchion panel light assembly.
2. Align the stanchion panel light assembly inside the stanchion as shown in Figure 7.
3. Extend the black (hot) and the white (neutral) wires to the base of the stanchion (these wires will be connected later, along with the strobe wires, to the incoming power wires in accordance with the electrical codes).
4. Secure the light assembly with the two mounting screws provided. Apply a small amount of clear RTV silicone sealant or equivalent to each screw thread to reduce the possibility of rust forming in the screw threads.
5. Insert the 7-watt compact fluorescent bulb provided with the assembly.
6. Secure the bezel and the lens to the stanchion.

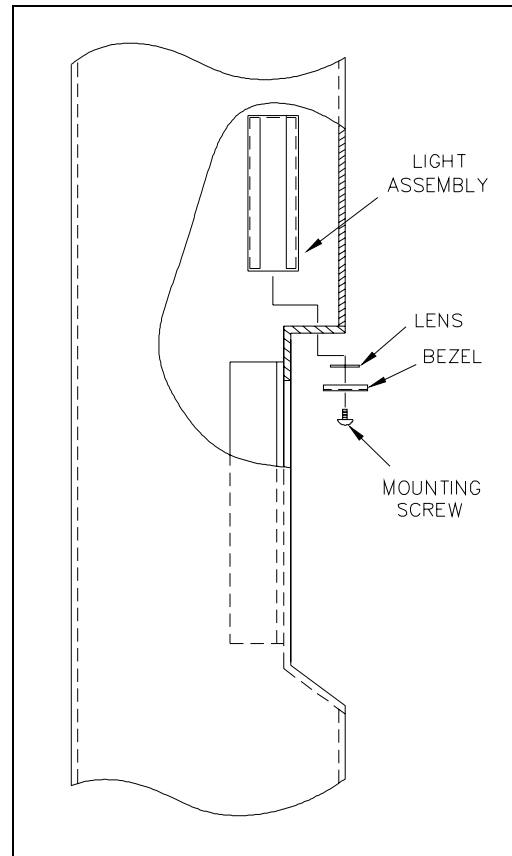

Figure 7. Stanchion Panel Light Assembly

Model 530-001 or 531A Strobe and 84502-201 Lens Cover Installation

1. Insert the strobe's seven 15-foot wires through the stanchion's threaded nipple, and allow the wires to extend to the base of the stanchion. See Figure 8.
2. Screw the strobe onto the threaded nipple. Secure the Model 84502-201 Lens Cover with four tamper-resistant screws.
3. Apply a small amount of clear RTV silicone sealant or equivalent to each screw thread to reduce the possibility of rust forming in the screw threads.
4. Separate the orange and violet wires necessary for the telephone connection, and extend those wires through the stanchion cutout for the telephone.

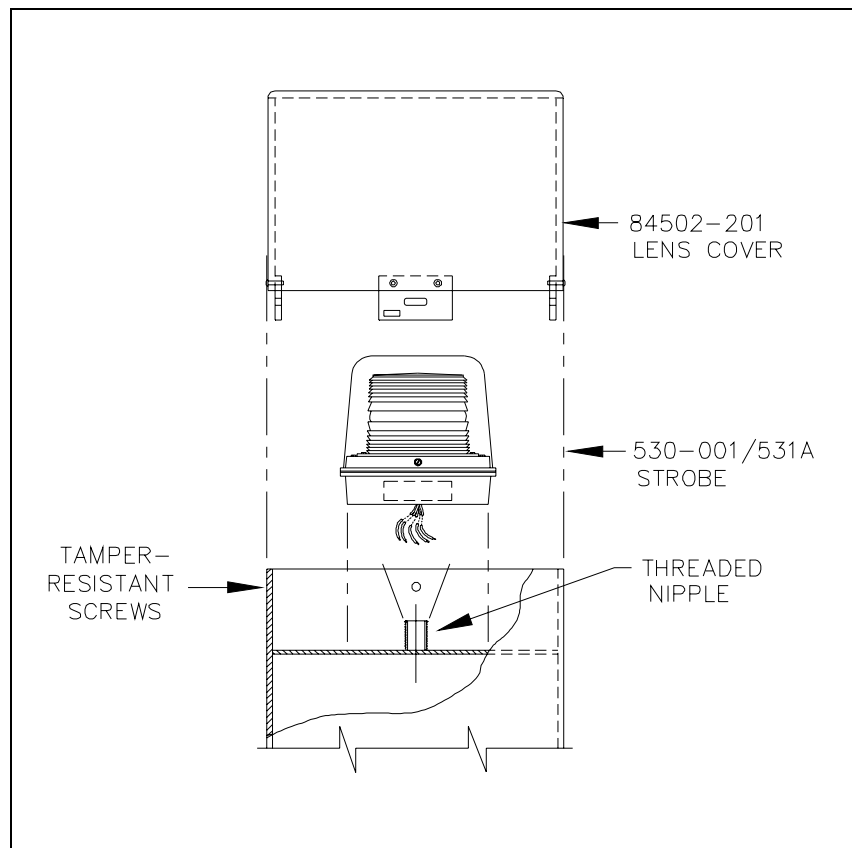

Figure 8. Strobe Assembly

Model 40201-010 Battery Installation

1. Batteries are shipped separately and are to be installed on site. Pay strict attention to battery polarity, as reverse power will cause damage to internal components.
2. Make the wiring connection to the electronics module labeled 12V BATTERY (red+, black-) with battery cable. It is recommended that this be left disconnected from the module until you are ready to power up the unit.
3. Attach the fast-on connectors to the batteries observing polarity (red+, black-) per drawing 73520.
4. Secure the batteries into L-bracket inside stanchion under phone opening.

NOTE: If the stanchion body does not have any L-brackets, the battery must be set in the bottom of the stanchion to the side, away from the conduit entries.

Refer to Pub. 42004-415, Model 10458-10x Electronics Paging Module Manual for interconnections and installation.

Emergency Telephone Installation

In addition to this publication, refer to the following manuals to assist in properly installing a complete station:

Pub. No.	Emergency Phone Model
Pub. 42004-352	Model 297-001 and 298-001 Flush-Mount Emergency Phones
Pub. 42004-351	Model 297-003 and 298-003 S.M.A.R.T. Flush-Mount Emergency Phones
Pub. 42004-377	S.M.A.R.T. Externally Powered Emergency Phones
Pub. 42004-378	Externally-Powered ADA-Compliant Emergency Phones
Pub. 42004-397	VoIP Telephones

1. Separate the back box from the front panel of the telephone. The parts envelope inside the back box contains eight #6-32 self-tapping flat head screws, six tamperproof screws, six washers, and a hole plug.
2. Place the back box into the phone opening from the front of the stanchion. Mount the box using four of the #6-32 self-tapping flat head screws. The telephone back box has an opening in the top and one in the bottom. Plug the top opening with a hole plug. The bottom of the back box is the recommended entry location for the telephone line and strobe control wires.

Install the phone's front panel using the six tamper-resistant screws and six washers provided.

NOTE: Excessive tightening will cause the panel to warp. Do not over-tighten.

Refer to the individual phone instruction manual (as listed above) for wiring details.

Wiring Power Connections

All wiring connections should be complete at this point, with the exception of the stanchion panel light and strobe wire connections to the incoming power lines. All connections must be made in accordance with the National Electrical Code (NEC) in the United States or the Canadian Electrical Codes (CEC) in Canada. Install the power lines as follows:

1. Install the recommended ac power line surge suppressor on the protection bracket.
2. Install a ground wire between the telephone line surge protection and the grounding lug.
3. Connect the incoming ac power line to the surge protection as shown in Figure 9.
4. Connect the red, white, and green wires of the Model 530-001 AC Strobe to the surge protection as shown in Figure 9. When using the Model 531A DC Strobe, connect the red and white wires to the dc power source as shown in Figure 10.
5. Connect the black, white, and green wires of the telephone light to the surge protection.

After making these connections according to the prevailing electrical codes, replace the access panel at the stanchion base using tamper-resistant screws.

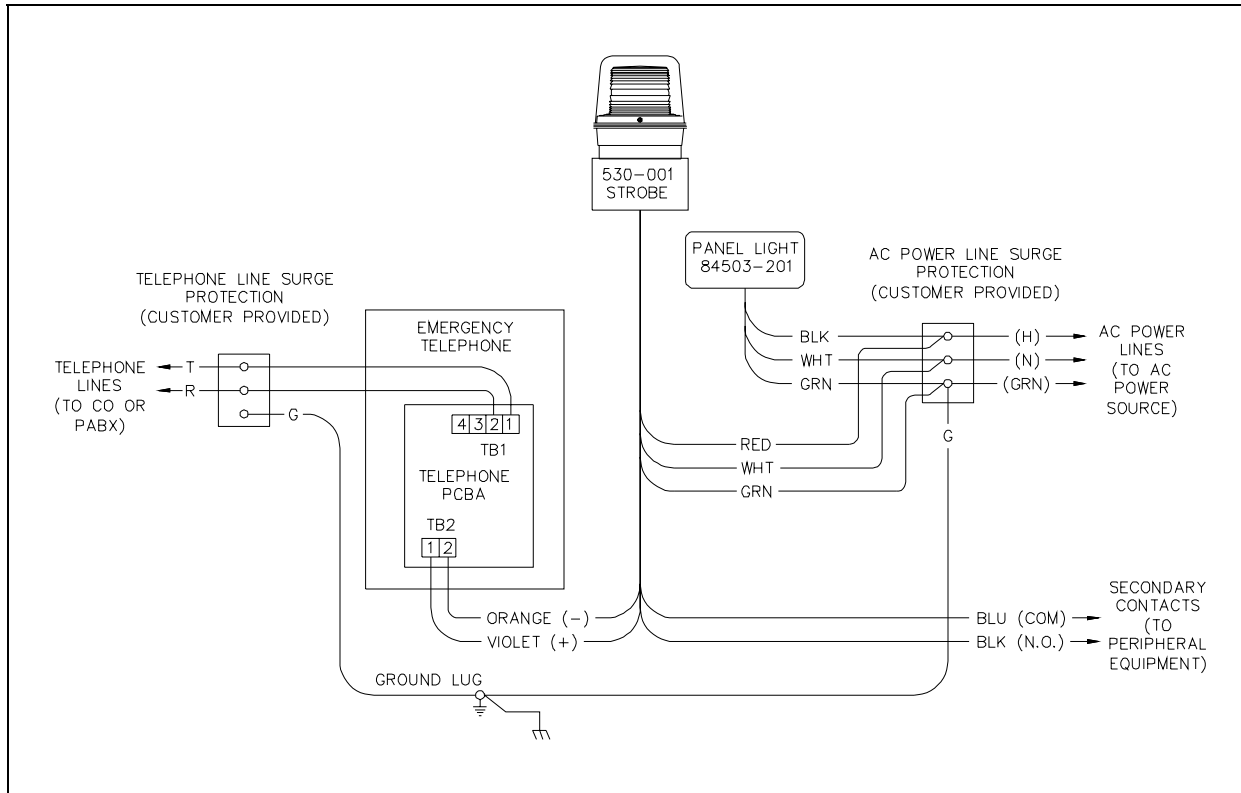

Figure 9. Interconnection Diagram with AC-Powered Strobe

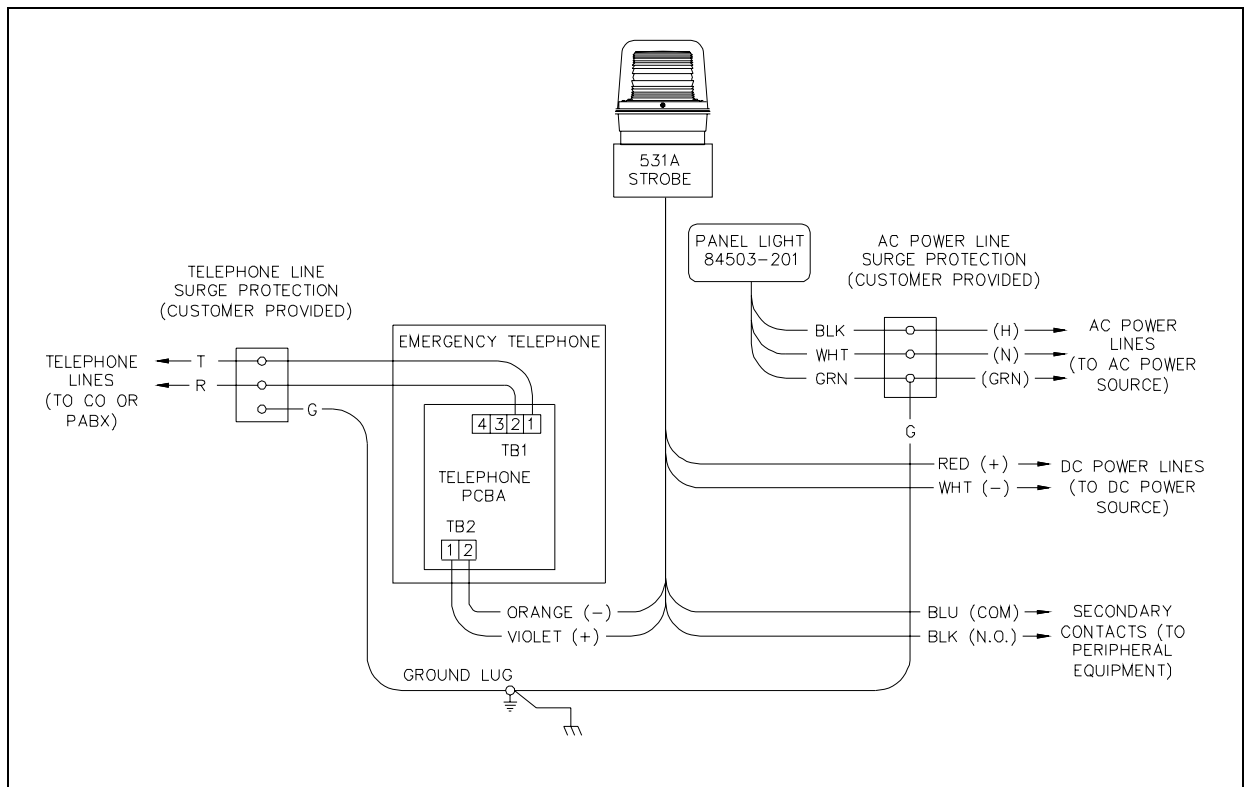

Figure 10. Interconnection Diagram with DC-powered Strobe

Repairing Surface Damage to Powder-Coated Stanchions

Scratch Repair

1. Carefully sand the damaged area to clean and score the base metal, taking care to minimize any additional damage to the surrounding powder coating.
2. Wipe the sanded area with a cleaning solvent, such as DuPont "PrepSol." Allow the area to dry. This type of product is available at auto parts stores. Denatured alcohol may also be used.
3. Prepare the bare metal surface for painting by treating it with phosphoric acid solution intended for this purpose. Allow the area to dry.
4. Using a cotton swap or small brush, paint the prepared surface with an automotive enamel or oil base polyurethane enamel such as Red Devil or Rustoleum. **DO NOT USE Krylon-type paints.** Carefully blend the repair enamel into the powder coat at the edges.
NOTE: EXACT color matches may not be attainable.

Decal Repair

1. Use a sharp instrument, such as an X-Acto knife, to loosen and lift a corner edge of the damaged decal.
2. Carefully peel back and remove the loosened decal.
3. Wipe the area clean with denatured alcohol. Allow the area to dry.
4. Prior to attaching a new decal, dampen the target area with a fine mist of water (fine spray from a plant misting bottle is ideal).
5. Peel the backing from the replacement decal, leaving the decal attached to the front cover material, and carefully align it with the target area.
6. With the cover material still attached, press the replacement decal in place, then squeegee any water from under the new decal starting at the center and working toward the edges.
7. Peel off the cover material, being careful not to tear or lift the decal. If the decal lifts as the cover material is being removed, push down on the uncovered decal, and squeegee as necessary to remove any large bubbles; small bubbles will disappear as the decal dries.

Specifications

Dimensions	10 W × 10 D × 114 H inches (0.25 × 0.25 × 2.89 m)
Wall thickness	3/16-inch hot-rolled steel
Finish	Powder-coated
Power rating (telephone light).....	120 V ac input/0.2 amp

Approvals:

UL/cUL listed OUTDOOR telephone stanchion Canadian Electrical Code, Part I (CE Code, Part I), and the ANSI/NFPA 70 National Electrical Code (NEC).

Warranty

Equipment. GAI-Tronics warrants for a period of one (1) year from the date of shipment, that any GAI-Tronics equipment supplied hereunder shall be free of defects in material and workmanship, shall comply with the then-current product specifications and product literature, and if applicable, shall be fit for the purpose specified in the agreed-upon quotation or proposal document. If (a) Seller's goods prove to be defective in workmanship and/or material under normal and proper usage, or unfit for the purpose specified and agreed upon, and (b) Buyer's claim is made within the warranty period set forth above, Buyer may return such goods to GAI-Tronics' nearest depot repair facility, freight prepaid, at which time they will be repaired or replaced, at Seller's option, without charge to Buyer. Repair or replacement shall be Buyer's sole and exclusive remedy. The warranty period on any repaired or replacement equipment shall be the greater of the ninety (90) day repair warranty or one (1) year from the date the original equipment was shipped. In no event shall GAI-Tronics warranty obligations with respect to equipment exceed 100% of the total cost of the equipment supplied hereunder. Buyer may also be entitled to the manufacturer's warranty on any third-party goods supplied by GAI-Tronics hereunder. The applicability of any such third-party warranty will be determined by GAI-Tronics.

Services. Any services GAI-Tronics provides hereunder, whether directly or through subcontractors, shall be performed in accordance with the standard of care with which such services are normally provided in the industry. If the services fail to meet the applicable industry standard, GAI-Tronics will re-perform such services at no cost to buyer to correct said deficiency to Company's satisfaction provided any and all issues are identified prior to the demobilization of the Contractor's personnel from the work site. Re-performance of services shall be Buyer's sole and exclusive remedy, and in no event shall GAI-Tronics warranty obligations with respect to services exceed 100% of the total cost of the services provided hereunder.

Warranty Periods. Every claim by Buyer alleging a defect in the goods and/or services provided hereunder shall be deemed waived unless such claim is made in writing within the applicable warranty periods as set forth above. Provided, however, that if the defect complained of is latent and not discoverable within the above warranty periods, every claim arising on account of such latent defect shall be deemed waived unless it is made in writing within a reasonable time after such latent defect is or should have been discovered by Buyer.

Limitations / Exclusions. The warranties herein shall not apply to, and GAI-Tronics shall not be responsible for, any damage to the goods or failure of the services supplied hereunder, to the extent caused by Buyer's neglect, failure to follow operational and maintenance procedures provided with the equipment, or the use of technicians not specifically authorized by GAI-Tronics to maintain or service the equipment. **THE WARRANTIES AND REMEDIES CONTAINED HEREIN ARE IN LIEU OF AND EXCLUDE ALL OTHER WARRANTIES AND REMEDIES, WHETHER EXPRESS OR IMPLIED BY OPERATION OF LAW OR OTHERWISE, INCLUDING ANY WARRANTIES OF MERCHANTABILITY OR FITNESS FOR A PARTICULAR PURPOSE.**

Return Policy

If the equipment requires service, contact your Regional Service Center for a return authorization number (RA#). Equipment should be shipped prepaid to GAI-Tronics with a return authorization number and a purchase order number. If the equipment is under warranty, repairs or a replacement will be made in accordance with the warranty policy set forth above. Please include a written explanation of all defects to assist our technicians in their troubleshooting efforts.

Call 800-492-1212 (inside the USA) or 610-777-1374 (outside the USA) for help identifying the Regional Service Center closest to you.